



TM4 Tail Light LED

A classic | new developed

A classic new developed

The newest technology – integrated LED failure control

The classic ERMAX TM4 LED tail light is well-known and has been used on vehicles all over Europe for many years. Due to new vehicle technology challenges with the light function recognition, ERMAX has new developed the classic TM4 LED tail light. The new TM4 tail light now meets the highest demands in the areas of technique, quality and functionality.

The design and build-in measures of the TM4 tail light have not been changed. Quite NEW is, however, the possibility of getting the tail light with integrated LED failure control for monitoring the direction indicator light and the stop light. This means that the vehicle is able to control the light functions according to ECE regulations.

The integrated LED failure control offers many advantages, as it supports both the ISO 13207 cold test and the state-of-the-art LED monitoring.

TM4 LED Tail light



The integrated LED failure control will solve many challenges

Highlights

- LED tail light with integrated LED control for monitoring the indicator and stop light in accordance with ECE 58.
- Use of a technology that is not only limited to ISO 13207 but also takes over the monitoring of older and new vehicles*.
- Control of flashing side marker lights (SIMAC®) by using rear cable with incorporated SIMAC®.
- Space-saving and fewer interfaces in the wiring harness, as no external control units / control boxes are required.
- Easy and quick mounting. Cost-saving due to reduction of mounting time and no maintenance.
- Classic design which can easily be combined with other existing lights.
- Possibility of a unique red-white-red design.
- D-approval and thus suitable for double mounting.
- IP69K rating of the LED unit (the tail light IP54K).
- ECE-, EMC- and ADR certified.

* Applies to all well-known brands in EU countries from 11/2009

Convincing technology

The best choice

The newest technology for monitoring and control of LED light functions

Using the newest technology in the ERMAX TM4 tail light enables integrated LED control to monitor the indicator and stop light function. If control of flashing side marker lamps SIMAC are needed ERMAX offers several innovative solutions, which can be connected easily and intelligently as a part of the cable system or as a plug-in solution.

- The integrated LED control in the tail light for monitoring the indicator and stop light functions, using a technology which is not limited to ISO 13207 and thus can be used for all vehicle* according to ECE R48.
- Intelligent control of the flashing side marker lights SIMAC® according to ECE R48 integrated in the rear cable.

Cable system with LED failure control for direct indicator and stop light function - integrated in the TM4 tail lights

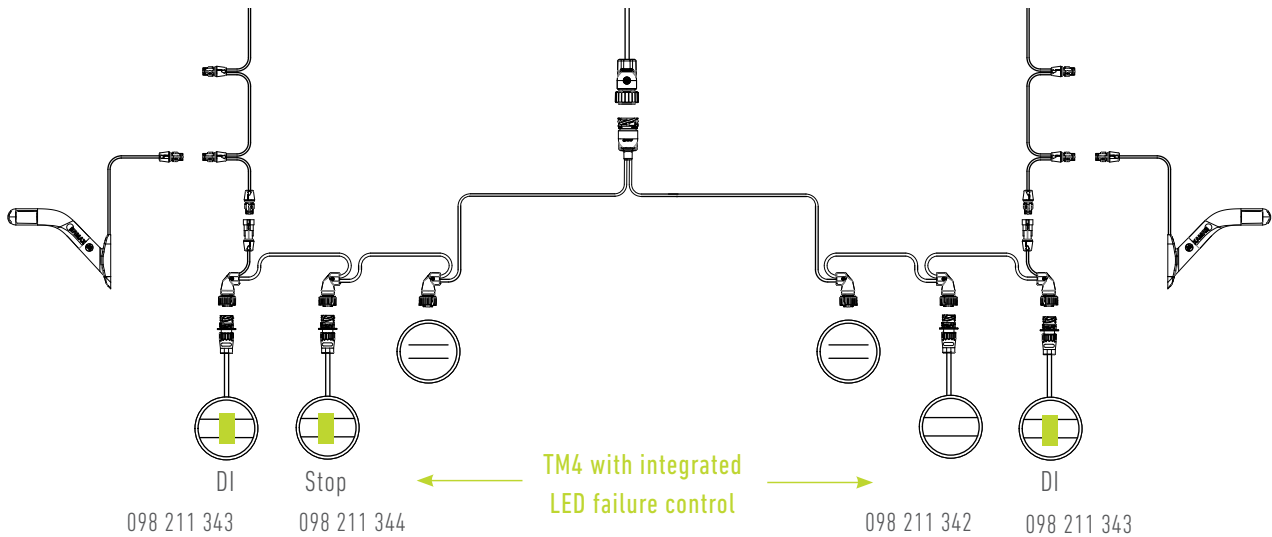

Cable system with LED failure control for direct indicator and stop light function integrated in the TM4 tail lights - and SIMAC® in the rear cable

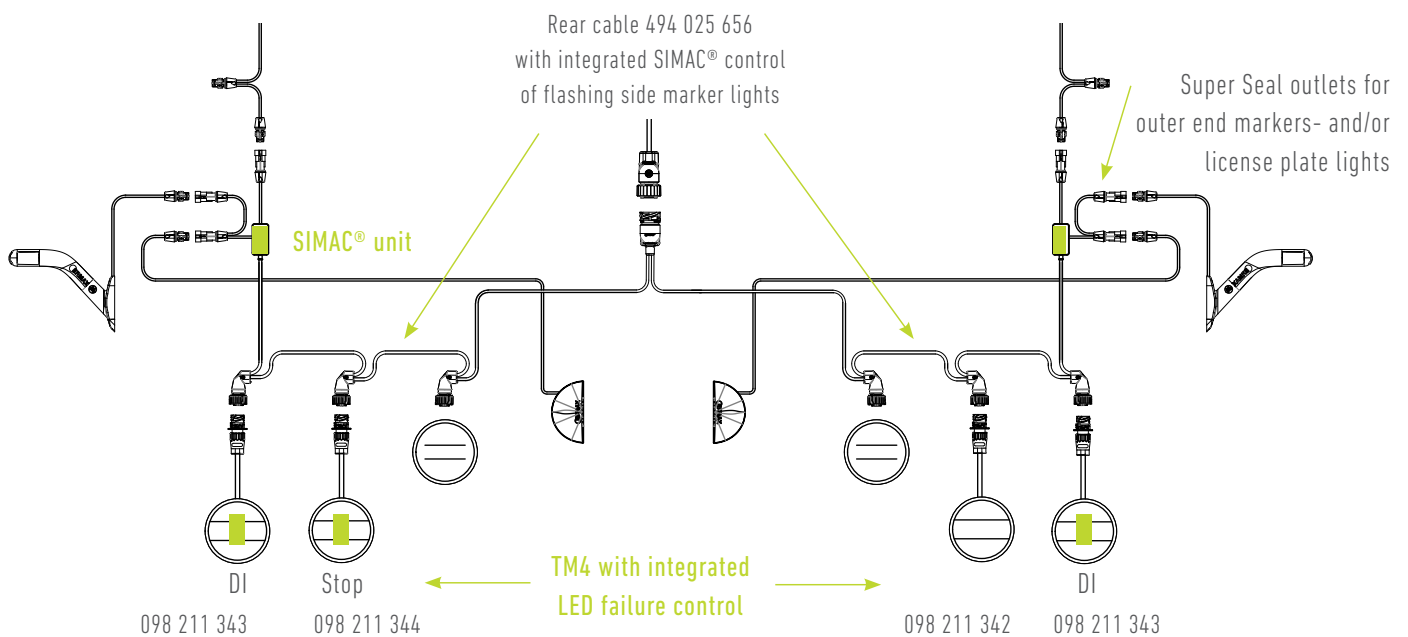

Variants & functions for every use

TM4 LED tail light Surface mounting	Voltage	Position Stop Indicator	Reverse	Rear fog	Connection	D-approval	LED control integrated	Article No.
--	---------	-------------------------------	---------	----------	------------	------------	---------------------------	-------------

Classic design - with D approval

	24V	✓			Cable lead through rubber grommet	✓		098 211 340
	24V	✓			300 mm cable with 7 pole AMP socket	✓		098 211 342
	24V	✓			Cable lead through rubber grommet	✓	Direct indicator light	098 211 341
	24V	✓			300 mm cable with 7 pole AMP socket	✓	Direct indicator light	098 211 343
	24V	✓			300 mm cable with 7 pole AMP socket	✓	Stop light	098 211 344

Classic design - without D approval

	12/24V	✓			Cable lead through rubber grommet			098 212 442
	12/24V	✓			300 mm cable with 7 pole AMP socket			098 212 436

Unique red-white-red design - with D approval

	12/24V	✓			Cable lead through rubber grommet	✓		098 212 345
	12/24V	✓			300 mm cable with 7 pole AMP socket	✓		098 212 339
	24V	✓			Cable lead through rubber grommet	✓	Direct indicator light	098 211 361
	24V	✓			300 mm cable with 7 pole AMP socket	✓	Direct indicator light	098 211 363
	24V	✓			300 mm cable with 7 pole AMP socket	✓	Stop light	098 211 364



Variants & functions for every use

TM4 LED tail light Surface mounting	Voltage	Position Stop Indicator	Reverse	Rear fog	Connection	D-approval	LED control integrated	Article No.
--	---------	-------------------------------	---------	----------	------------	------------	---------------------------	-------------

Combination rear light - reversing and rear fog - without D approval

	12/24V		✓	✓	Cable lead through rubber grommet			098 255 340
	12/24V		✓	✓	300 mm cable with 7 pole AMP socket			098 255 342

Single-function rear light - reversing and rear fog - without D approval

	24V		✓		Cable lead through rubber grommet			098 256 343
	12/24V		✓		300 mm cable with 7 pole AMP socket			098 256 336
	12/24V			✓	Cable lead through rubber grommet			098 257 349
	12/24V			✓	300 mm cable with 7 pole AMP socket			098 257 336

Material description

Lens:	PMMA
Housing:	PP
Measure:	Ø140 x 80 mm
Bolt distance:	45 mm / M6
Working temperature:	-40°C - +65°C
IP-Rating:	IP54 (LED-Einheit: IP69K)

LED failure control on functions that are not preconfigured

The ERMAX TM4 tail light is pre-configured to monitor a specific light function as described above.

If monitoring of a different light function is required, this can be changed by changing a pair of plug connections. Information can be found on page 7.

Rear underrun protection bar with TM4 tail lights

According to ECE 58 revision 3

- Classical elegant design - new developed
- LED failure control and SIMAC® integrated
- Also possible in the unique red and white design



Integrated LED failure control for monitoring the direction indicator function and stop light function



098 259 075



098 259 095

Measure (WxDxH): 2780 (2400 mm without OEM) x 160 x 252 mm

Variant - ECE58-03

Typ	Verteilerbox	SIMAC	LED Ausfallkontrolle		Artikel-Nr.
			Blinklicht	Bremslicht	
LED	✓	✓	✓	✓	098 259 075 *
LED	✓	✓	✓	✓	098 259 095 **

* With D approval

** The triangular reflectors must be mounted separately

Drawings, measure and spare parts

TM4 LED tail light with rubber grommet

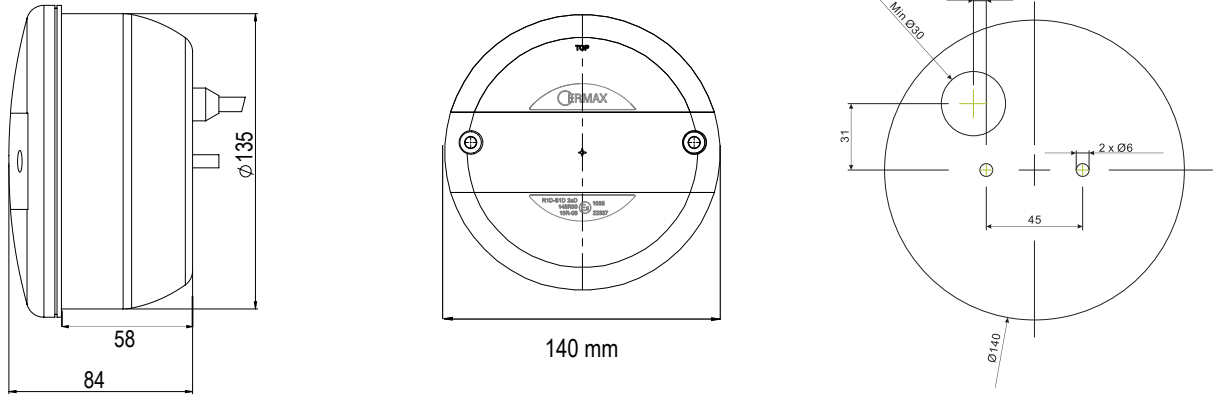

TM4 LED tail light with 300 mm connection cable with 7 pole AMP socket

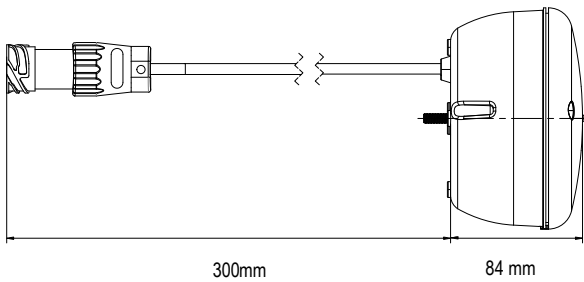

LED failure control on functions that are not preconfigured

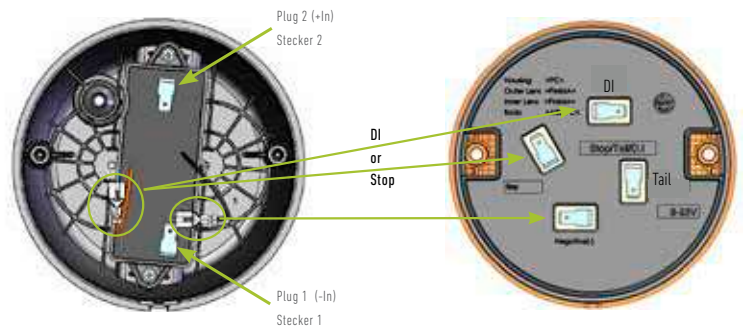

Spare parts and accessories



Chrome ring and built-in kit	1	098 292 360
Protection cover for tail light	2	098 296 720
TM4 housing with LED failure control unit 24V, cable lead through rubber grommet, for monitoring the direct indicator or stop light function	3	098 298 114

Die Marken der BPW Gruppe:

