

... **BPW**  
**air suspension**

A plus to  
your efficiency





# Air suspension with intuition for all your requirements.

Because the topic of transport business is central for you, we do everything to make transportation of your cargo reliable and safe. The solution: the ECO Plus running gear with air suspension from BPW. The air suspension systems are exactly suited to all kinds of road conditions while giving due consideration to your economic viability. Best example: the ECO Air COMPACT – our air suspension standard.



## Intelligent running gear systems

Your running gear requirements are individual and at the same time complex. In BPW running gear, path-breaking technologies and top-quality components are designed to exactly fit your requirements.



### Axle systems

The square axle beam with factory-set toe-in and camber will keep you on track in an efficient way.





### Suspension systems

The BPW air suspension systems protect your vehicle and your cargo in a reliable way wherever you use them.



### Brake technology

Brake systems, developed specifically for trailers. Extremely powerful, easy to service and durable.



### Telematics solutions

With TControl from BPW you have a clear view of all information and can increase your efficiency.



# BPW air suspension systems. For every application.

BPW air suspension systems have proven themselves millions of times worldwide, whether it's a platform semitrailer for long-distance transport or a tipping trailer in a quarry. The modular structure of the BPW air suspension makes your running gear suitable for every application. BPW air suspension systems combine high efficiency with the best driving characteristics and stability.

## Your benefits:

- Easy servicing due to modular construction
- Investment security and high availability of replacement parts
- Highest driving comfort and sensitive handling of the cargo
- Surface protection by means of cataphoretic dip-coating with zinc-phosphating KTL<sub>Zn</sub>



## ECO Air COMPACT PAGE 6 – 9

*Perfectly tuned to the requirements of the standard vehicles*

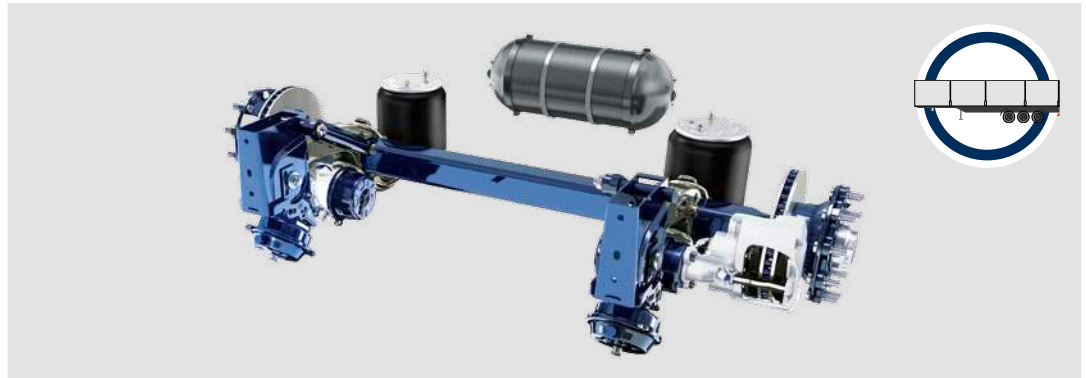

<b>Axle loads</b>	9 t
<b>Operating conditions</b>	On-road

Curtainsider      Closed box      Insulated superstructure      Swap body

## Air suspension systems PAGE 10 – 11

*For special applications and higher axle loads*

### Universal application

*Airlight II for weight-sensitive applications down to the light off-road application with 9 t*



<b>Axle loads</b>	9 t–10 t
<b>Operating conditions</b>	Off-road/ light off-road application

Curtainsider      Insulated superstructure  
Closed box      Swap body

### Uncompromisingly reliable

*SL air suspension for every application of up to 12 t*



<b>Axle loads</b>	9 t–12 t
<b>Operating conditions</b>	On-Road/Off-Road

Tank/silo superstructure      Vehicle transport  
Tipper/low-loader

## Air suspension components

**A system is more than the sum of all individual components.**

More about air suspension components: Page 12–13

All about your No 1 international mobility partner and our service features: Page 16–19



**-30%**

fewer module variants –  
for more flexibility

**-60%**

lighter GFRP air tanks compared to steel –  
for more additional load

**100%**

maintenance-free integration –  
for reduced operating costs

**ECO Plus Guarantee**

5+3 years with unlimited mileage – for safe driving  
across Europe

**Robust design**

Long lifetime





# -50%

fewer air suspension components – for a robust design and long service life

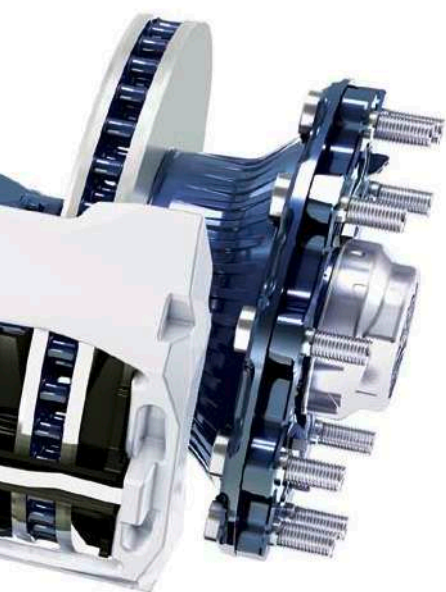

# -50%

reduced installation time due to newly designed axle lift

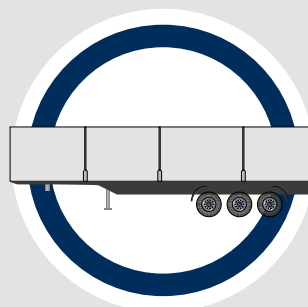

## ECO Air COMPACT. Our new standard.

The modular air suspension ECO Air COMPACT and the lightest ECO Air tanks combine to form an optimum system: our standard for 9 t axles in on-road application. Its innovative developments make the system faster, easier and lighter in many respects. Whether it's logistics, manufacture, application on the road or maintenance: ECO Air COMPACT gives you more efficiency always and everywhere.

<b>Axle loads</b>	9 t
<b>Steering arm</b>	Cast trailing arm, width 100 mm
<b>Application</b>	On-road
<b>Brakes</b>	Disc brake (TSB), drum brake (SN)
<b>Tyres</b>	Single wheels (19.5" and 22.5") Offset ET 120 (TSB) Offset ET 0 (SN)
<b>Air suspension hanger brackets</b>	Steel air suspension hanger brackets
<b>Options</b>	Axle lift, combination airbag



Detailed information about ECO Air COMPACT can be found at  
<http://www.bpw.de/en/products/commercial-vehicles/suspension-systems/eco-air-compact-air/details.html>

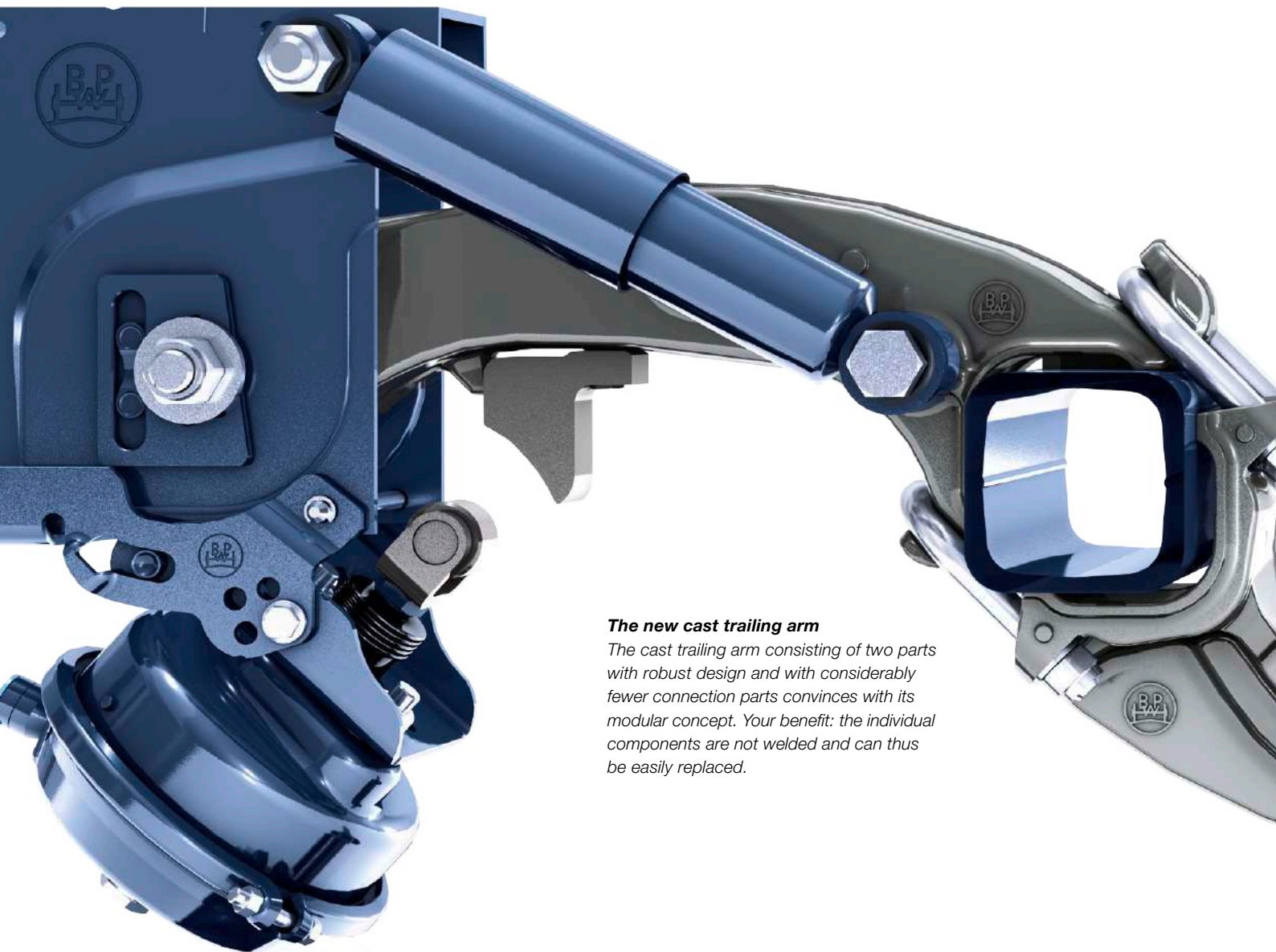

**The new cast trailing arm**

*The cast trailing arm consisting of two parts with robust design and with considerably fewer connection parts convinces with its modular concept. Your benefit: the individual components are not welded and can thus be easily replaced.*

## ECO Air COMPACT. The highlights.



**Steel-rubber bush**

*The special steel-rubber bush has an asymmetric design, is load-adapted and has no recesses. Its optimum axial and vertical guiding system increases driving comfort and reduces tyre wear. Homogenous force absorption as well as even stress distribution ensures smooth operation and long service life.*



**Double-sided axle lift**

*The pre-mounted unit can be easily installed on the hanger bracket or cast trailing arm. The weight has been reduced by 12 kg and the installation time by 50% compared to the previous systems.*



# ECO Air COMPACT.

## Economic viability in every detail.

The ECO Air COMPACT is adapted to leaner manufacturing processes used by the vehicle manufacturers. Therefore trailer installation can be further optimised: fewer variants and simplified installation save time and costs needed for installation. And the hauliers can benefit, too: because the system, including ECO Air tanks, is absolutely maintenance-free and the components can be replaced by modules. In addition, the innovative details such as the diagonal screw connection or the special steel-rubber bush ensure a long service life – and therefore lasting efficiency for your trailer.



A video about ECO Air COMPACT can be found at BPW TV  
<http://www.bpw.de/en/media/bpw-tv.html>



### **Adjustable hanger bracket**

Two adjustable hanger brackets in the whole modular system provide the vehicle manufacturer with optimum latitude for axle alignment



### **ECO Air tank**

The new 30 to 120 litre GFRP ECO Air tanks allow a weight reduction of up to 60% compared to the steel air tanks (with 2 x 60 l). The high-tech composite material as well as the special production process ensures a long service life.



## Long service life

Robust and easy to service BPW technology

## Extreme

Riding heights  
of up to 220–600 mm

## Outstanding ride characteristics

Suspension units with  
long-stroke air bags

## Heavy-duty air suspension

With single or double leaf  
trailing arms

## Off-road application

Welded integration

The picture shows  
SL air suspension

## The heavy-duty package from BPW.



From the reinforced axle beam down to the heavy-duty air suspension, these BPW running gears provide the maximum performance, increased driving comfort and safety – even on the most difficult terrain.

### Features and benefits:

- Robust design
- Reinforced axle beam (120 x 15 mm or 150 x 20 mm)
- Reinforced single or double leaf trailing arms
- Reinforced air suspension hanger brackets
- Air bags with a diameter of 360 mm and a reinforced base plate
- Heavy-duty shock absorbers
- With ECO Plus guarantee with unlimited mileage. See page 13.



# ECO Plus Guarantee

5+3 years with unlimited mileage

## Flexible installation

Modular construction



### Comparative data.

#### Airlight II



<b>Axle loads</b>	9 t – 10 t
<b>Steering arm</b>	Single leaf trailing arm, width 70 mm, height 56 mm (standard), 62 mm (reinforced)
<b>Application</b>	Off-road, light off-road application (tippers, Western Europe)
<b>Brakes</b>	Disc brake (TSB), drum brake (SN)
<b>Tyres</b>	Single wheels (19,5" up to 22,5") Offset ET 0/ET 120 (TSB) Offset ET 0 (SN) Twin wheels (TSB/SN)
<b>Air suspension hanger brackets</b>	Steel air suspension hanger brackets
<b>Options</b>	Self-steering axle, stainless steel/aluminium hanger brackets, axle lift, channel crossmember, PDC shock absorber, 3D trailing arm, combination airbag

#### SL air suspension



<b>Axle loads</b>	9 t – 12 t
<b>Steering arm</b>	Single and double leaf trailing arms, 100 mm width
<b>Application</b>	On-road, off-road
<b>Brakes</b>	Disc brake (TSB, 19.5"–22.5"), drum brake (SN)
<b>Tyres</b>	Single wheels Offset ET 0 (TSB) Offset ET 0 (SN) Twin wheels (TSB/SN)
<b>Air suspension hanger brackets</b>	Steel air suspension hanger brackets
<b>Options</b>	Self-steering axle, axle lift, PDC shock absorber

# Air suspension systems. For special applications and higher axle loads.

#### SL air suspension and Airlight II

The strength of the SL air suspension and the Airlight II is their modular design. It makes installation and service of both systems easier. The flexibility of SL and AL II is also apparent during transportation. Thus, even the most demanding axle loads of 12 t when driving off road can be handled without difficulties. In addition, the Airlight II has an optimised weight (395 kg ALO with TSB 3709 and ET 0) and a 5+3 year guarantee for on-road use. And it does not require maintenance for axle loads of up to 9 t.



Detailed information on SL air suspension can be found at <http://www.bpw.de/en/products/commercial-vehicles/suspension-systems/sl-air/details.html>



Detailed information on Airlight II can be found at <http://www.bpw.de/en/products/commercial-vehicles/suspension-systems/airlight-ii-air/details.html>



# Features and additional components of BPW air suspension systems.

Every detail of our products provides 100% BPW quality, leading running gear know-how – and a great deal of advantages. See it for yourself.



### **Air suspension hanger brackets**

Short, adjustable BPW air suspension hanger brackets with integrated shock absorber fixing facilitate installation and reduce the weight and bending load for the vehicle frame. The vehicle manufacturer benefits from straightforward cross-bracing options at the interface between the frame and the hanger bracket. BPW hanger brackets with integrated wheel alignment allow a quick air suspension alignment. Standard BPW air suspension hanger brackets are made of steel but are also available as stainless steel, aluminium and bolt-on variants.



### **Divided air suspension (combination airbag)**

The modular design of air suspension allows the possibility of different solutions. Best example: combination airbag. It prevents damage to air bags when transporting vehicles by different means of transport (road, railway, sea).



### **The air bag**

Air bag provides excellent suspension of the superstructure and allows an adjustment of vehicle frame through the "lift" and "lower" functions.



### **Axle lifts for every mounting situation**

All BPW axle lift devices – whether they are two-sided lifts or central lifts, lateral or central axle lifts – reduce tyre wear and are notable for a low weight, easy installation and KTL<sub>Zn</sub> coating.



#### **Tuned damper systems**

Intelligent PDC shock absorbers (PDC = Pneumatic Damping Control) automatically detect the load conditions and correspondingly adapt to them. This means: optimum damping, improved road behaviour, higher safety, higher comfort and lower maintenance costs.



#### **Surface protection**

Running gears from BPW offer robust technology for a long vehicle service life. One of many examples: cathaphoretic dip-coating with zinc-phosphating (KTL<sub>Zn</sub>). Or a special finish providing a 5 times higher corrosion protection than usual coating process.



#### **Easy integration of self-steering axles**

With 3D single leaf trailing arms and integrated support, a self-steering axle can be integrated into a standard vehicle frame with minimal changes.



#### **ECO Plus Guarantee**

You can completely rely on the BPW quality factor: our ECO Plus guarantee period is 5 years (for on-road applications). European-wide and with unlimited mileage. In addition you have the option to extend your guarantee for a further 3 years.





**The more intelligent your running gear is, the more you will benefit from it.**

Because the larger the product portfolio is, the more versatile the application possibilities are. Economic viability is best achieved when development in vehicle concept through to trailer manufacture occur in close cooperation with the supplier. Our extensive engineering services, ECO Plus running gear, the user-friendly telematics and intelligent additional components from the BPW Group make BPW the right system partner.

**For you, this particularly means:**

- Individual advice on vehicle design
- High-quality equipment: BPW – The Quality Factor
- Custom-made logistics concepts to support your manufacturing process

## System partner

### Intelligent running gear systems

Your running gear requirements are individual and at the same time complex. In BPW running gear, path-breaking technologies and top-quality components are designed to exactly fit your requirements.

- Axle systems
- Suspension systems
- Braking technology incl brake cylinders
- Telematics solutions

### Intelligent trailer components

Exactly what you need: the BPW trailer components. From robust steel landing gears and light aluminium ECO wheel through to the innovative plastic components such as ECO Air tank.

- Lifting belt systems, rear portals, stakes, locks
- Tractor connection devices, fifth wheels, landing gear, turntables
- Mud wings, air bag pistons, air tanks
- Lighting systems
- ECO Wheel



# The group of companies

The BPW Group with more than 40 affiliates worldwide is your partner for economic engineering and consulting. And never far away.

**HESTAL**   
 LOCKS YOUR LOAD BEST

**Sealing/Chassis technology**

- Belt lift systems
- Rear doors
- Stanchions
- Sealings

hesterberg.de

 **ERMAX**®

**Lighting/cable systems**

- Tail lamps
- Position lamps
- Indicators
- Side marker lamps etc.

transport-technik.dk

**idem**..  
 transport solutions

**Telematics**

- Real-time monitoring
- Temperature monitoring
- Tyre pressure control
- Integration of existing telematic systems

idem-gmbh.com

 **HBN-Teknik** A/S  
 Automotive Solutions in Composites

**Plastic technology**

- Mudguard
- Air spring piston
- Air tanks

hbn.dk





# TControl: more mobility for transport companies.

Reliable products, comprehensive technical documentation, manuals, quickly available genuine spare parts – this is our contribution to your everyday transport business. Our affiliates and partners in 43 countries provide optimal support – from spare part identification through to remote diagnosis via TControl telematics solution.

## For you, this particularly means:

- Investment security (5+3 years warranty with unlimited mileage)
- High availability (24hr mobility service)
- Competent contacts worldwide (3,200 service partners)
- Low operating costs (genuine spare parts worldwide)
- Efficient fleet management (TControl)

## 3,200 service partners worldwide

Predictive maintenance planning and short response times with our 24h service. Our service network ensures your mobility - because one of our service partners is never far away even if you are en route.

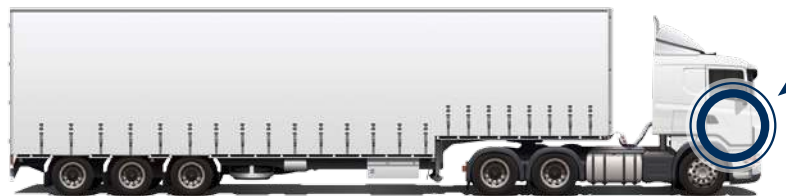

## Full control of the vehicle

The solution for all vehicle types: with our telematics solution you are always up-to-date about your vehicles. And you can act whenever required. The result: you have more safety en route and reduce your operating costs.

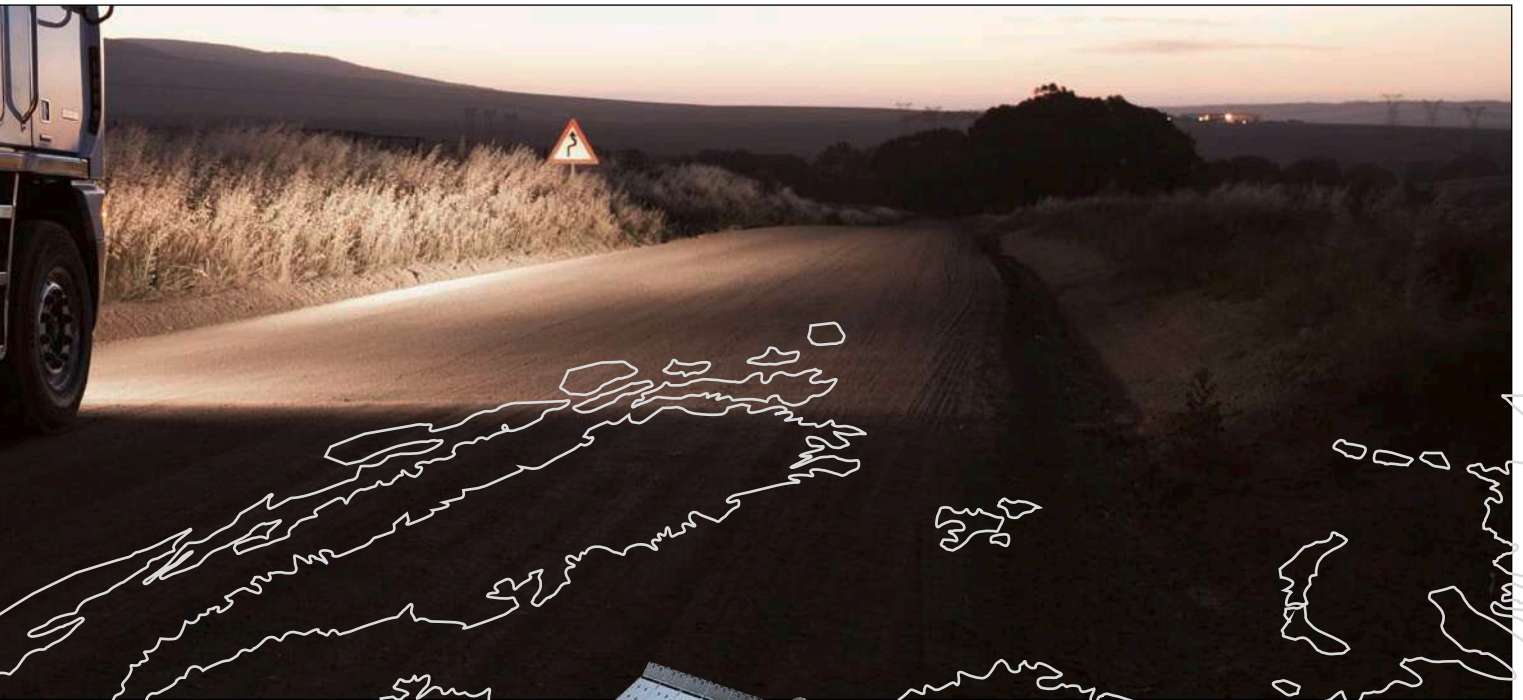

### Trailer-based telematics

It's all about transportation. We provide all important information at a glance: location, route, EBS data, door activities, tyre pressure and cooling temperature.



### Efficient fleet management

You know which data you need. We provide you with analyses – clearly arranged and in real time. In addition: active alarms via e-mail, SMS or mobile apps. Reliable, day and night.





# Our service. Your benefit.

We will be glad to provide you with our running vehicle technologies and our trailer electronics. But there is still much more for you. The information below provides an overview about our comprehensive service and product packages. More information can be found at [www.bpw.de](http://www.bpw.de)

## BPW services

### Workshop and fleet support

The worldwide BPW service network and high spare parts availability are an integral part of our international mobility partnership as well as personal support and advice, 365 days a year, 24 hours a day.

For quick assistance – the BPW service hotline:  
+49 (0) 2262 78-0

### Engineering und Consulting

As a vehicle manufacturer, you can take advantage of our construction know-how and individual engineering services (e.g. FEM, brake or tilting stability calculations). In addition to the advice by our specialists, we can optionally support you with the individual logistics concepts.

Your personal contact person is available for you at [www.bpw.de/en/support/engineering](http://www.bpw.de/en/support/engineering)

### Trainings and seminars

From professionals for professionals – with certification. BPW offers a comprehensive seminar programme targeted at vehicle manufacturers, hauliers, workshops and trade partners. We provide practical information and advice for you.

The programme is available at [www.bpw.de/en/support/seminars](http://www.bpw.de/en/support/seminars)

### Partner Service Package

Take advantage of our special maintenance contract with custom conditions for new semi-trailers and trailers with drum brake or disc brake BPW running gear systems. Your benefit: you can define the scope yourself and enjoy an absolute cost safety and transparency due to a fixed monthly instalment.

For more information see [www.bpw.de/en/support/partner-service-package](http://www.bpw.de/en/support/partner-service-package)

### Logistics concepts

High availability, lower costs, more efficiency. This is what you can have from the sophisticated BPW logistics concept. With a personal contact and custom solutions according to your requirements, based on the BPW logistics centre ensuring the timely delivery of the ready-to-install components.

For more information see [www.bpw.de/en/support/logistical-concepts](http://www.bpw.de/en/support/logistical-concepts)



SEBAICE



#### Technical documentation

Whether for installation, maintenance or spare parts ordering – all technical documentation from BPW has a structure that is based on the content, target group and media and is essential for the user. BPW user information is prepared with the same care as BPW products – our quality standards are not limited to the products.

Comprehensive downloads are available at [www.bpw.de/en/support/downloads/general-download-area](http://www.bpw.de/en/support/downloads/general-download-area)

#### Documented manufacture

Our certified manufacture ensures that every component and every functional group in BPW running gear vehicles matches and has the same high quality. In parallel to the process, all relevant production and assembly procedures as well as quality and functional checks are documented – to give the best possible transparency, safety and security.

For more information see [www.bpw.de/en/company/competences](http://www.bpw.de/en/company/competences)

#### BPW 24 hour breakdown service hotline

BPW technology gives you safety en route. In the event of a breakdown, the hauliers can call the free 24 hour breakdown service hotline in 39 European countries. Every caller can use his own language. The breakdown service network with more than 3,200 BPW service partners and 4,500 support stations are at your disposal when you need help.

An immediate assistance can be requested at 00800 780 780 00 or [www.bpw.de/en/support/customer-service](http://www.bpw.de/en/support/customer-service)

## BPW service en route

Download the "BPW Mobile" app now: [www.bpw.de/en/app](http://www.bpw.de/en/app)







# Your partner on the path to **economic viability!**

BPW is a globally leading manufacturer of intelligent running gear systems for trailers and semi-trailers. As an international mobility and system partner, we offer a wide range of solutions for the transport industry from a single source, from axle to suspension and brake to user-friendly telematics applications. We thereby ensure outstanding transparency in loading and transport processes and facilitate efficient fleet management. Today, the well-established brand represents an international corporation with a wide product and service portfolio for the commercial vehicle industry. Offering running gear systems, telematics, lighting systems, composite solutions and trailer superstructures, BPW is the right system partner for automotive manufacturers.

BPW, the owner-operated company, consistently pursues one target: To always give you exactly the solution which will pay off. To this end, we focus our attention on uncompromising quality for high reliability and service life, weight and time-saving concepts for low operating and maintenance costs as well as personal customer service and a close-knit service network for quick and direct support. You can be sure that with your international mobility partner BPW, you always use the most efficient method.

