

Tough by design,
economical in use.

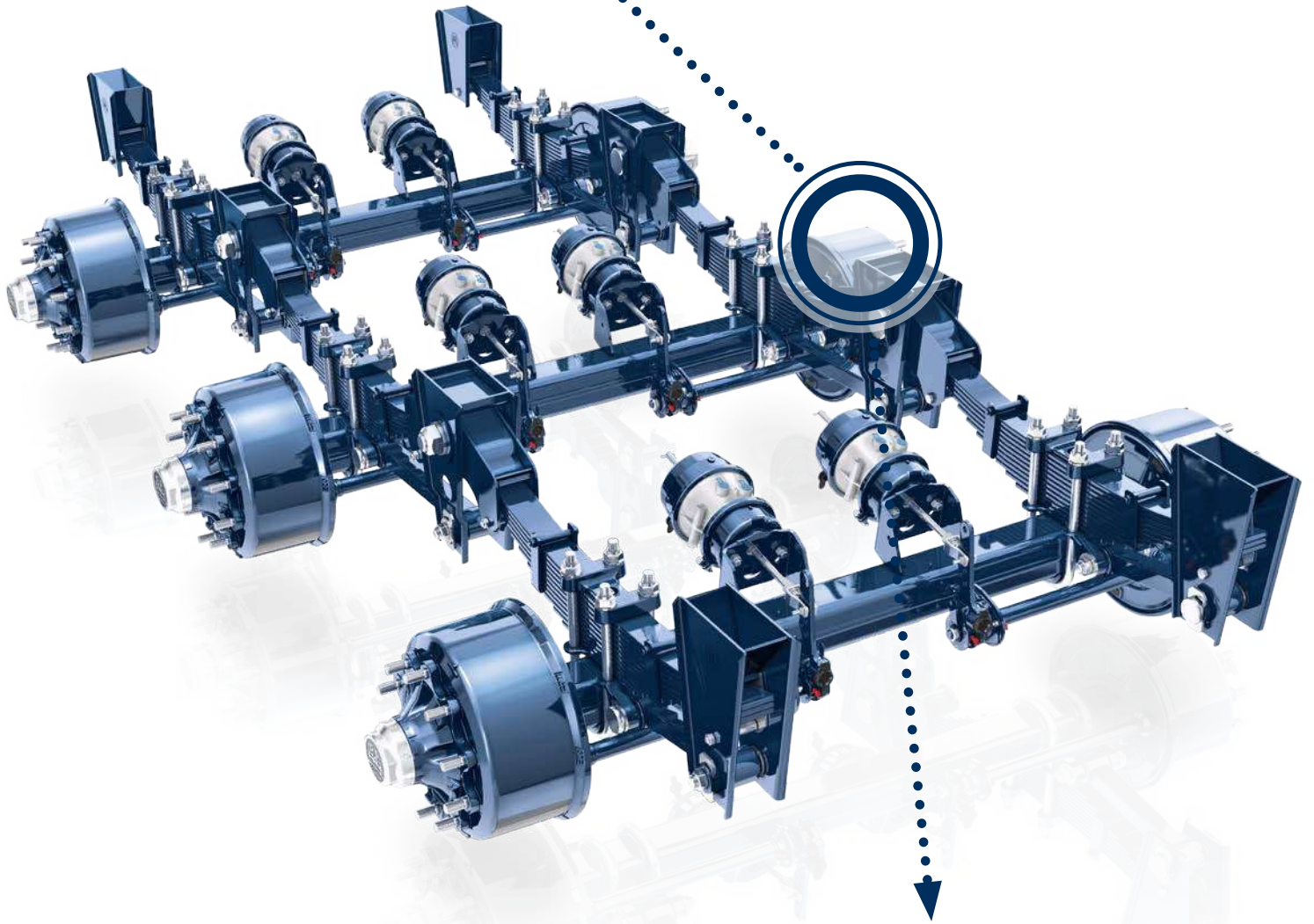

BPW

ECO Cargo VB

Cost-effectiveness for heavy duty applications in the 9 – 12 tonnes range.

ECO Cargo VB

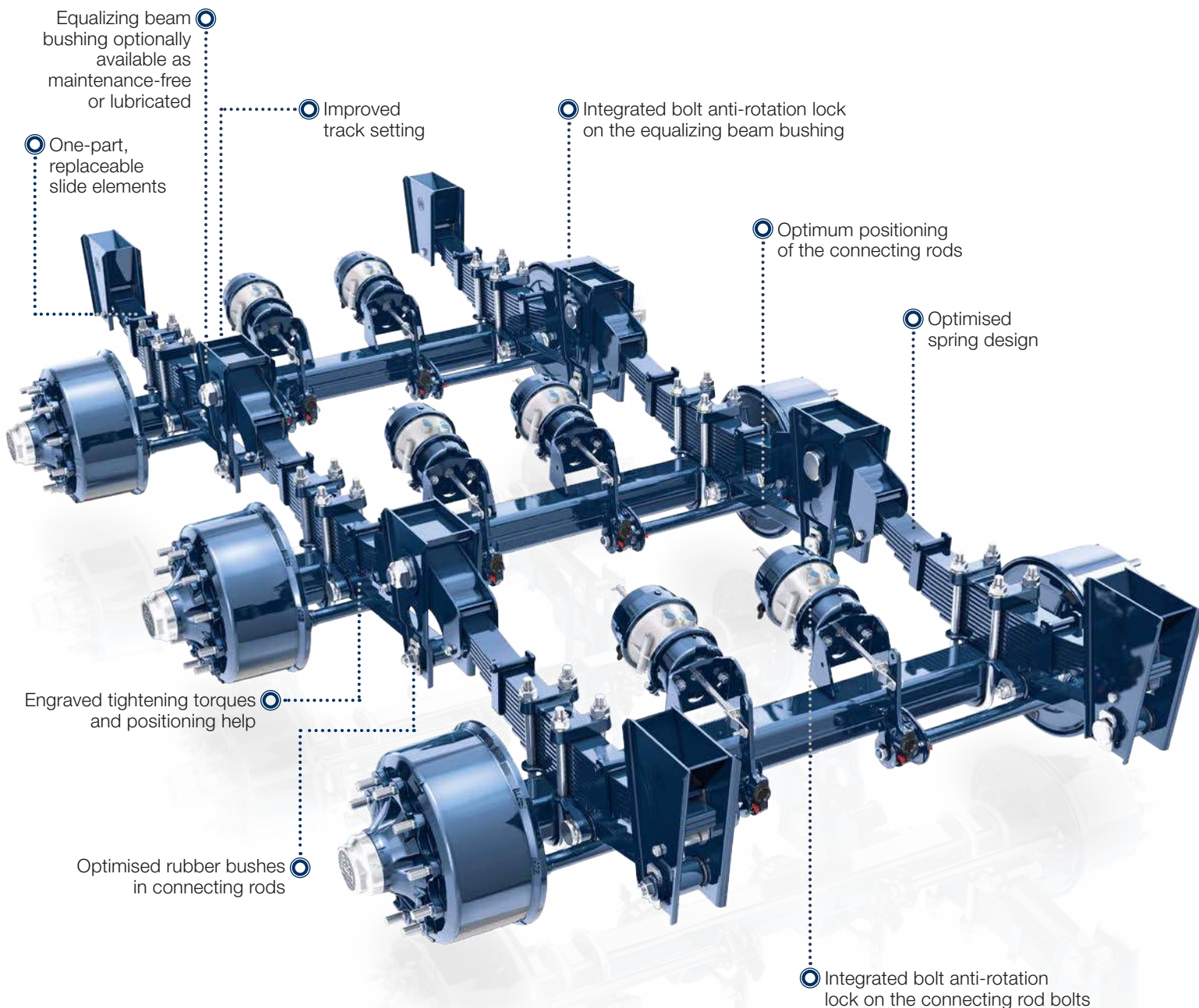

Equalizing beam bushing optionally available as maintenance-free or lubricated

One-part, replaceable slide elements

Improved track setting

Integrated bolt anti-rotation lock on the equalizing beam bushing

Optimum positioning of the connecting rods

Optimised spring design

Engraved tightening torques and positioning help

Optimised rubber bushes in connecting rods

Integrated bolt anti-rotation lock on the connecting rod bolts

An overview of product data:

Product features:

- For axle loads of nine to twelve tonnes
- Applications for one to three axles
- Can be supplied with parabolic springs or multi-leaf springs
- Hanger brackets can be zinc-coated
- Static axle load equalization through equalizing beams
- Equalizing beams can be supplied in maintenance-free rubber-steel-bushes or lubricated bronze bushes

Type	Single axle	2-axle	3-axle	Axle beam	S-cam brake	Track (TR) (mm)	Spring centre (SR) (mm)	Air cylinder centre (AR) (mm)	Tyre example ²⁾ (mm)	M = minimum offset dim. ET = Offset
HSFVB	9.010	2/9.010	---	120	SN 4218	2,040	1,300	525	385/65 R22.5	ET 0
HSFVB	9.010	2/9.010	3/9.010	120	SN 4218	2,040	1,300	525	385/65 R22.5	ET 0
HSFVB	9.010	2/9.010	3/9.010	120	SN 4218	2,040	1,300	525	385/65 R22.5	ET 0
HSFVB	9.010	2/9.010	3/9.010	120	SN 4218	2,040	1,300	525	385/65 R22.5	ET 0
HSFVB	9.010	2/9.010	3/9.010	120	SN 4218	2,010	1,200	495	385/65 R22.5	ET 0
HZFVB	9.010	2/9.010	3/9.010	120	SN 4218	1,820	900	335	275/70 R22.5	M = 320
NHZFVB	12.010	2/12.010	---	120	SN 3020	1,830	980	239	245/70 R17.5	M = 290
NHZFVB	12.010	2/12.010	3/12.010	120	SN 3020	1,950	1,100	243	245/70 R17.5	M = 290
HSFVB	12.010	2/12.010	3/12.010	150	SN 4220	2,040	1,300	365	445/65 R22.5	ET 0
HSFVB	12.010	2/12.010	3/12.010	150	SN 4220	2,040	1,300	365	445/65 R22.5	ET 0
HZFVB ¹⁾	12.010	2/12.010	3/12.010	150	SN 4220	1,820	900	261	295/80 R22.5	M = 330
HSFVB	12.010	2/12.010	3/12.010	150	SN 4220	2,040	1,300	365	445/65 R22.5	ET 0
HSFVB	12.010	2/12.010	3/12.010	150	SN 4220	2,000	1,200	325	445/65 R22.5	ET 0
HSFVB	12.010	2/12.010	3/12.010	150	SN 4220	2,040	1,300	365	445/65 R22.5	ET 0
HSFVB	12.010	2/12.010	3/12.010	150	SN 4220	2,000	1,200	325	445/65 R22.5	ET 0
HZFVB ¹⁾	12.010	2/12.010	3/12.010	150	SN 4220	1,820	900	261	295/80 R22.5	M = 330
HZFVB ¹⁾	12.010	2/12.010	3/12.010	150	SN 4220	1,850	980	241	295/80 R22.5	M = 330
HZFVB ¹⁾	---	2/12.010	3/12.010	150	SN 4220	1,820	900	261	295/80 R22.5	M = 330
HZFVB ¹⁾	---	2/12.010	3/12.010	150	SN 4220	1,850	980	241	295/80 R22.5	M = 330

1) Can also be supplied as Trilex type: Type name HIZVB... The track widths change according to the tyre size and spacer ring

2) Take note of the details supplied by the tyre manufacturer regarding load index and dimensions.

3) Take account of clearance for dynamic upward travel and equalizing route with suspension axles

4) Weight without wheels and tyres; weight tolerances are within the permitted DIN tolerances for the respective production procedures.

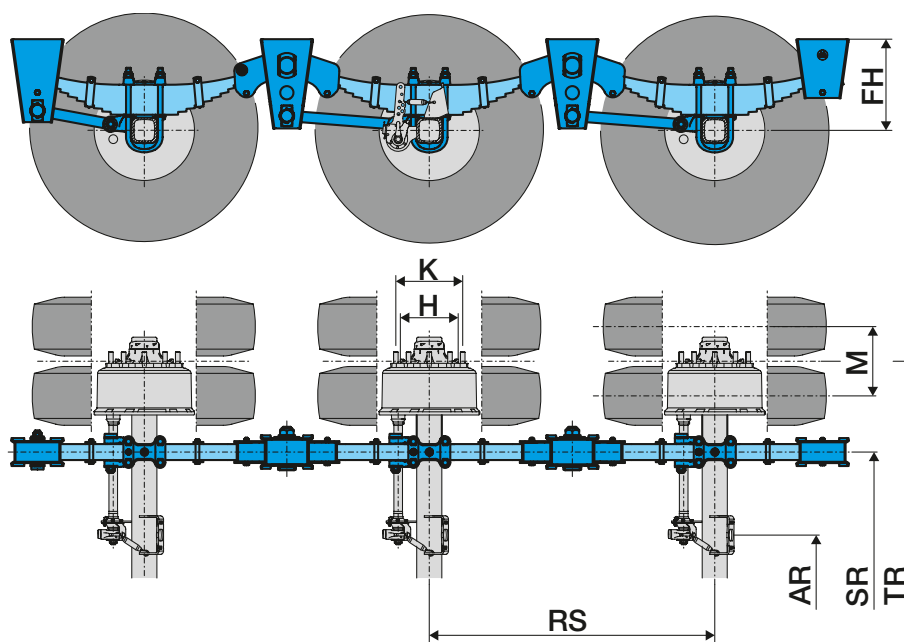

Overall width above the tyres (mm)	Wheel connection		Wheel base (RS) (mm)	Hanger bracket	Ride height (FH) (mm)				Suspension weight ⁴⁾ (kg)		
	Wheel stud	Diameter H/K (mm)			with multi-leaf spring		with parabolic springs		Single axle	2-axle	3-axle
					Loaded ³⁾	Unloaded	Loaded ³⁾	Unloaded			
2,435	10 x M22x1.5	280.8/335	1,310	low	---	---	232	256	427	896	---
2,435	10 x M22x1.5	280.8/335	1,310	medium	---	---	268	292	430	891	1,353
2,435	10 x M22x1.5	280.8/335	1,360	medium	337	379	---	---	489	1,009	1,530
2,435	10 x M22x1.5	280.8/335	1,360	high	367	409	---	---	494	1,015	1,536
2,405	10 x M22x1.5	280.8/335	1,360	high	367	409	---	---	493	1,013	1,533
2,432	10 x M22x1.5	280.8/335	1,360	high	367	409	---	---	491	1,009	1,527
2,365	10 x M22x1.5	175.8/225	1,310	low	---	---	232	256	429	900	---
2,485	10 x M22x1.5	175.8/225	1,310	medium	---	---	268	292	445	921	1,368
2,505	10 x M22x1.5	280.8/335	1,310	high	---	---	313	337	502	1,031	1,560
2,505	10 x M22x1.5	280.8/335	1,360	high	---	---	388	412	529	1,084	1,640
2,465	10 x M22x1.5	280.8/335	1,360	high	---	---	388	412	530	1,086	1,643
2,505	10 x M22x1.5	280.8/335	1,360	medium	375	417	---	---	578	1,189	1,799
2,465	10 x M22x1.5	280.8/335	1,360	medium	375	417	---	---	577	1,187	1,796
2,505	10 x M22x1.5	280.8/335	1,360	high	405	447	---	---	584	1,194	1,805
2,465	10 x M22x1.5	280.8/335	1,360	high	405	447	---	---	583	1,192	1,802
2,465	10 x M22x1.5	280.8/335	1,360	high	405	447	---	---	585	1,196	1,808
2,495	10 x M22x1.5	280.8/335	1,360	high	405	447	---	---	592	1,210	1,829
2,465	10 x M22x1.5	280.8/335	1,820	high	405	447	---	---	---	1,232	1,879
2,495	10 x M22x1.5	280.8/335	1,820	high	405	447	---	---	---	1,246	1,900

For higher axle loads, select the tried and tested ECO Cargo VB HD. We should be happy to supply any further information you might require.

A 4-axle combination can be supplied following discussion with BPW.

All multi-axle versions are available with rubber or bronze bushes in the equalizing beam.

BPW's proven technology. Everywhere at home.

Wherever the conditions pose a challenge and the next workshop cannot be reached, BPW mechanical suspension comes into its own. This is because the VB suspension has been constructed in such a way that it can also cope with difficult road conditions and can be quickly and easily repaired, should this be required. Furthermore, the latest generation possesses an optimised bushing of the connecting rods and low-wear, long life wear plates. Assembly and, in particular, track setting have however also been made even easier by employing tried and tested technology from the high-volume BPW air suspension series. The precise track setting as well as optimum positioning of the connecting rods, after all, ensure less tyre wear and therefore even more cost-effectiveness.

Your advantages at a glance:



Cost-effectiveness

- Lower tyre wear through precise track setting and optimum positioning of the connecting rods
- Increased life expectancy through optimised positioning of the connecting rods
- Fewer spare parts due to improved utilisation of parts within the BPW series.
- High spare part availability through more than 3,200 service partners
- Higher efficiency in production process through flexible and rationalisation of the product range
- Clearly distinguished from pirate versions thanks to the engraved BPW logo



Assembly-friendly

- Improved track setting through technology from the tried and tested high-volume BPW air suspension series
- Built-in bolt anti-rotation lock on equalizing beam and connecting rod bolts as standard.
- Engraved assembly information
- Easily accessible bolt connections



Robust

- Low-wear, replaceable, one-part wear plates
- Low ride heights with overslung suspension with maximum ground clearance possible
- Spring design optimised and synchronised to the area of application





RTS-RIEGELTEAM.DE ECO Cargo VB 15481301 e

We tread the path of **economic viability!**

BPW is the world's leading manufacturer of intelligent running gear systems for trailers and semi-trailers. As your system partner, we provide the complete trailer fleet from a single source, from axle, suspension and brake through to the user-friendly telematics applications. Our solutions create the highest transparency in loading and transport processes and allow an efficient fleet management.

BPW, the owner-operated company, consistently pursues one target: To always give you exactly the solution which will pay off. To this end, we focus our attention on uncompromising quality for high reliability and service life, weight and time-saving concepts for low operating and maintenance costs as well as personal customer service and a close-knit service network for quick and direct support. You can be sure that with your international mobility partner BPW, you always use the most efficient method.

BPW Bergische Achsen Kommanditgesellschaft

Postfach 12 80 · 51656 Wiehl, Germany · Phone +49 (0) 2262 78-0
info@bpw.de · www.bpw.de

