

L
LL

Workshop manual

BPW steering axles



BPW-WH-LL-L 35351701e

we think transport



Valid: 01.02.2017

Subject to change without notice.

Current versions and additional information can be found online at www.bpw.de.

Contents

◎ 1. Product identification	Page 4
1.1 Explanation of BPW axle type codes (extract)	Page 4
1.2 Explanation of BPW axle code numbers (extract)	Page 5
◎ 2. Exploded view / name	Page 8
◎ 3. Safety regulations, safety information	Page 12
3.1 Safety regulation	Page 12
3.2 Safety information	Page 13
◎ 4. Tightening torques	Page 14
◎ 5. Special tools	Page 15
◎ 6. Lubrication intervals - Steering axles with drum and disc brake	Page 16
◎ 7. Maintenance intervals - Steering axles with drum brake	Page 18
◎ 8. Maintenance intervals - Steering axles with disc brake	Page 20
◎ 9. Steering axles with drum brake	Page 22
9.1 Manual slack adjuster (GSK)	Page 22
9.2 Automatic slack adjuster (ECO-Master)	Page 25
9.3 Brake camshaft	Page 28
9.4 Booster brackets	Page 31
9.5 Brake bolt	Page 34
9.6 Brake plate	Page 36
◎ 10. Steering axles with disc brake	Page 38
10.1 Screwing the brake caliper to steering axles with „ECO Disc“ disc brake	Page 38
10.2 Tangential screwed joint of the brake caliper SB 3745, SB 4309 and SB 4345	Page 40
10.3 Axial screwed joint of the brake caliper SB 3745 and SB 4345	Page 41
◎ 11. Track rod, LL series	Page 42
◎ 12. Steering lock, LL series	Page 46
◎ 13. Steering damper, LL series	Page 48
13.1 Steering damper Ø 32 mm	Page 48
13.2 Steering damper Ø 82 mm	Page 52
◎ 14. Steering pivot bearing	Page 54
14.1 Steering pivot bearings, LL series	Page 54
14.2 Steering pivot bearings, L series	Page 64
◎ 15. Tracking check	Page 70
15.1 Checking and, if necessary, correcting toe-in (LL-series)	Page 70
15.2 Conventional axle alignment check on the vehicle	Page 72
15.3 Axle alignment check on the vehicle with laser measuring system	Page 74
◎ 16. Functional check under the vehicle	Page 75

1 Product identification

1.1 Explanation of BPW axle type codes (extract)

Example:										
SH	S	M	H	LL	9010	/12°	ECO Plus 2			
							Axle series	Brake	Tyre	Year of manuf.
SH							SH.. <input type="checkbox"/>	TSB 4309	22.5	07/2009 ->
SH							SH.. <input type="checkbox"/>	SB 4345	20" / 22.5" / 24"	1996 ->
SH							SH.. <input type="checkbox"/>	SB 4309	22.5"	05/2003 ->
SKH							SKH.. <input type="checkbox"/>	TSB 3709	19.5" (22.5")	07/2009 ->
SKH							SKH.. <input type="checkbox"/>	SB 3745	19.5" (22.5")	1998 ->
SM							SM.. <input checked="" type="checkbox"/>	TSB 4312	20" / 22.5" / 24"	2013 ->
SM							SM.. <input checked="" type="checkbox"/>	TSB 4309	22.5"	07/2009 ->
SKM							SKM.. <input checked="" type="checkbox"/>	TSB 3709	19.5" (22.5")	07/2009 ->
H							H.. <input type="checkbox"/>	SN 420	20" / 22.5" / 24"	1988 ->
M							M.. <input checked="" type="checkbox"/>	SN 420	20" / 22.5" / 24"	1988 ->
KH							KH.. <input type="checkbox"/>	SN 360	19.5"	1988 ->
KM							KM.. <input checked="" type="checkbox"/>	SN 360	19.5"	1988 ->
NH							NH.. <input type="checkbox"/>	SN 300	15" / 17.5" (12")	1988 ->
NM							NM.. <input checked="" type="checkbox"/>	SN 300	15" / 17.5" (12")	1988 ->
B										For single wheels, wheels with offset
S										For single wheels, wheels without offset
Z										For twin wheels
F										Wheel studs M 22x1.5 without wheel nuts; order wheel nuts for stud or spigot alignment separately
M										For spigot alignment / Alloy wheels
A										With alloy hubs
H										For hanging boosters
L										Power steering axle - steering angle max. 45°
LL										Self-steering axle, series LL - steering angle max. 27°
6410 to 16010										Axle load (kg) + quantity of wheel studs per hub
-1										Type of hub bearing
/6° to /45°										Steering angle of steering axle
ECO Plus 3										Trailer axle with ECO Plus 3 Unit
ECO Plus 2										Trailer axle with ECO Plus 2 Unit
ECO ^{Plus}										Trailer axle with ECO ^{Plus} Unit
ECO-MAXX										Weight-optimised ECO axle built as from 1997
ECO										Trailer axle with helical fit wheel bolts
MAXX										Weight optimised trailer axle with helical fit wheel bolts

Definition of symbols	
<input type="checkbox"/>	Square beam hollow axle
<input checked="" type="checkbox"/>	Square beam solid axle

Explanation of BPW axle code numbers (extract)

1.2

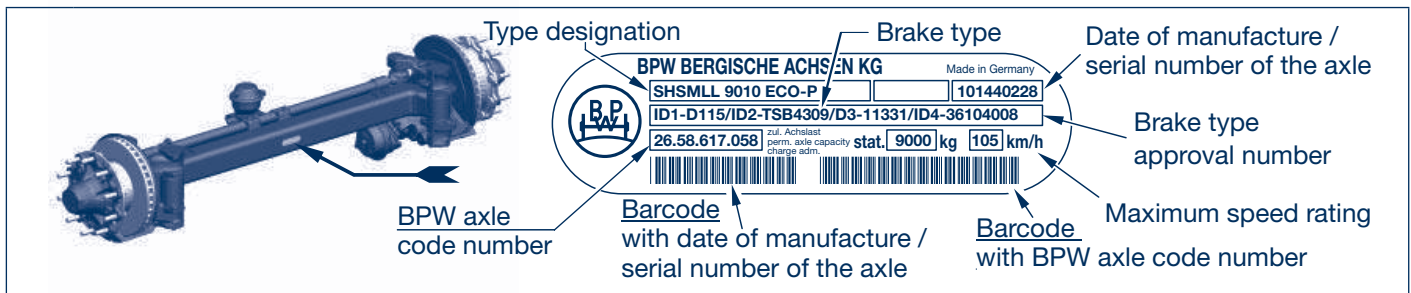

Example:					
26.	58.	617.	058		
		Axle type			
26.		BPW steering axle			
29.		BPW steering axle			
36.		BPW steering axle			
		Axle load	Roller bearings	Bearing generation	
08.		8000 - 9000 kg	33116 / 32310	conventional hub bearing	
10.		10000 - 12000 kg	33118 / 32313	conventional hub bearing	
14.		13000 - 14000 kg	32219 / 33215	conventional hub bearing	
16.		16000 - 18000 kg	32222 / 33214	conventional hub bearing	
38.		8000 - 9000 kg	33116 / 32310	ECO Unit	
40.		10000 - 12000 kg	33118 / 32313	ECO Unit	
44.		13000 - 14000 kg	32219 / 33215	ECO Unit	
48.		8000 - 9000 kg	33118 / 33213	ECO ^{Plus} Unit	
50.		10000 - 12000 kg	33118 / 33213	ECO ^{Plus} Unit	
58.		8000 - 9000 kg	33118 / 33213	ECO Plus 2 Unit	
68.		8000 - 9000 kg	33118 / 33213	ECO Plus 3 Unit	
		Wheel brake type	Dimension	Type	Year of manuf.
11.		SN 3020 BPW 95	Ø 300 x 200	Brake BPW 95	2015 ->
20.		SN 3620 BPW 95	Ø 360 x 200	Brake BPW 95	2015 ->
31.		SN 4218 BPW 95	Ø 420 x 180	Brake BPW 95 / ECO Drum	2015 ->
32.		SN 4220 BPW 95	Ø 420 x 200	Brake BPW 95 / ECO Drum	2015 ->
40.		TSB 3709	Ø 370	Disc brake ECO Disc	2015 ->
41.		TSB 4309	Ø 430	Disc brake ECO Disc	2015 ->
545.		SN 3620 KWG	Ø 360 x 200		1995 ->
552.		SN 3620 KWG	Ø 360 x 200	Brake BPW 95	1995 ->
585.		SN 3020-1 KWG	Ø 300 x 200		1988 ->
609.		SB 4345	Ø 430	Disc brake	1996 - 4/2003
610.		SB 3745	Ø 370	Disc brake	1996 - 4/2003
612.		SB 3745 T	Ø 370	Disc brake	5/2003 - 2010
613.		SB 4309 T	Ø 430	Disc brake	5/2003 - 2010
614.		SB 4345 T	Ø 430	Disc brake	5/2003 - 2010
616.		TSB 3709	Ø 370	Disc brake ECO Disc	7/2009 ->
617.		TSB 4309	Ø 430	Disc brake ECO Disc	7/2009 ->
618.		TSB 4312	Ø 430	Disc brake ECO Disc	2013 ->
713.		SN 4218-2 KWG	Ø 420 x 180		1988 - 1995
722.		SN 4220-2 KWG	Ø 420 x 200		1988 - 1995
741.		SN 4212 BPW 95	Ø 420 x 120	Brake BPW 95	1995 ->
743.		SN 4218 BPW 95	Ø 420 x 180	Brake BPW 95 / ECO Drum	1995 ->
744.		SN 4220 BPW 95	Ø 420 x 220	Brake BPW 95 / ECO Drum	1995 ->
		000 - 999	Consecutive number in which details as to track, wheel connection, ABS (antiskid system) and AGS are defined.		





2 Exploded view

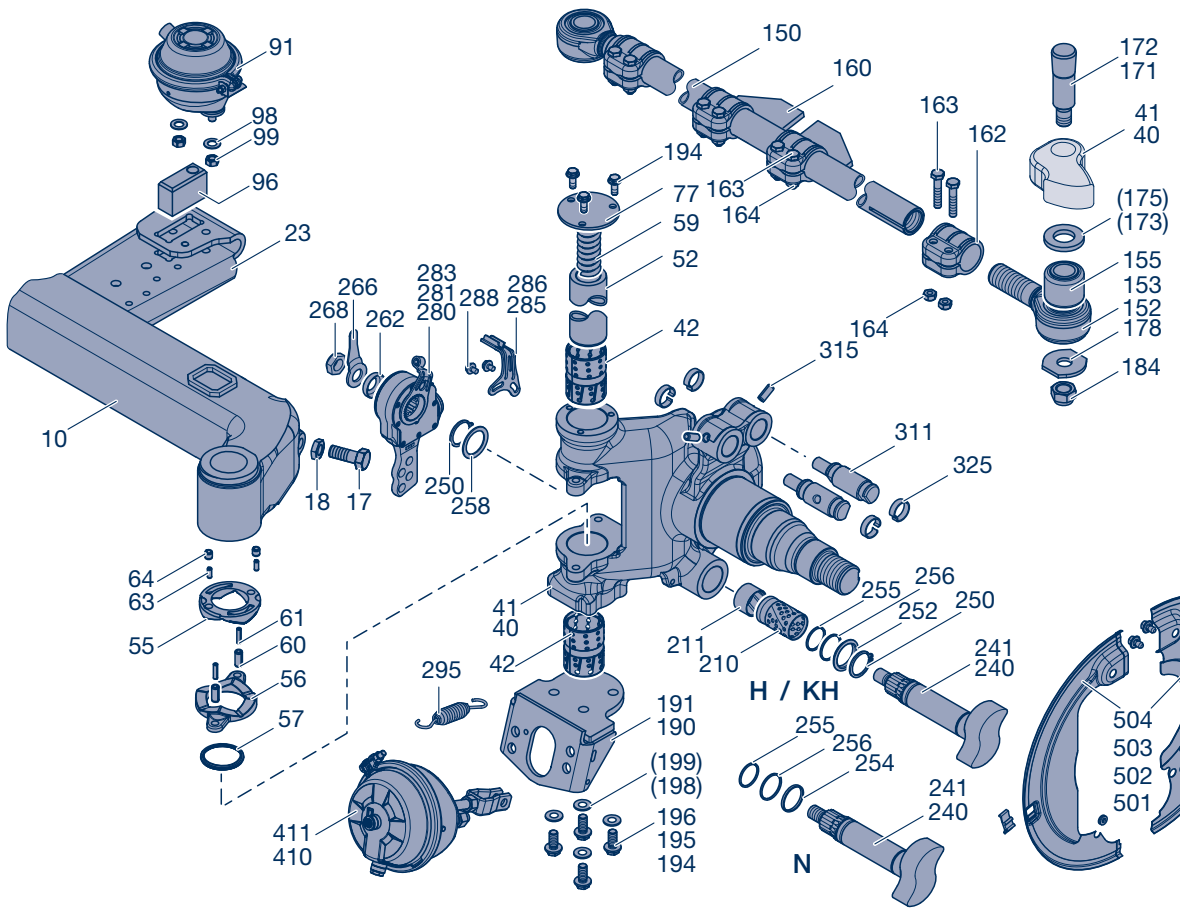

Steering pivot bearing, series L

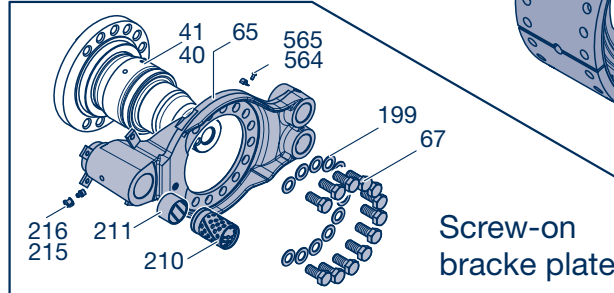
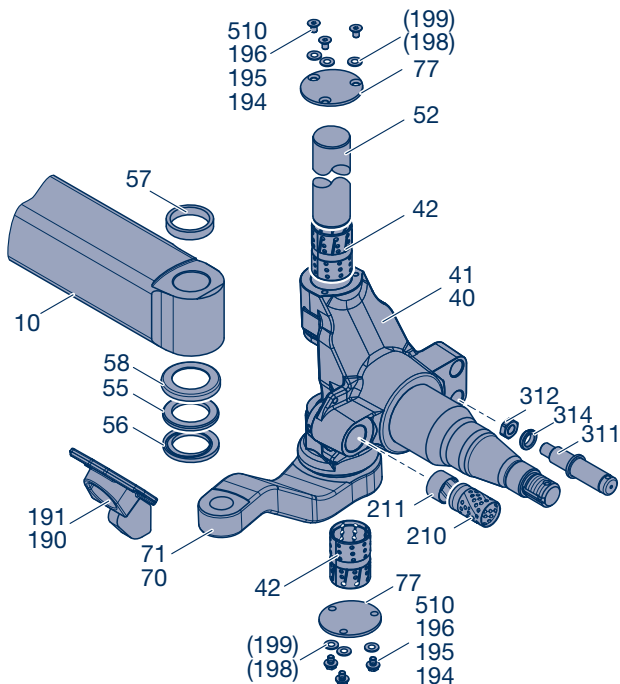

Screw-on bracket plate

Steering damper Ø 32 mm

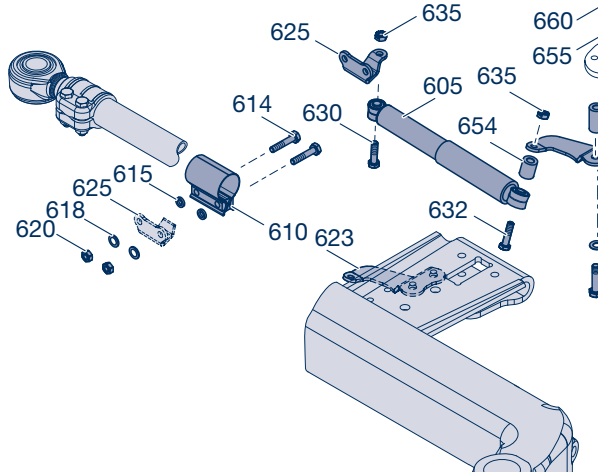

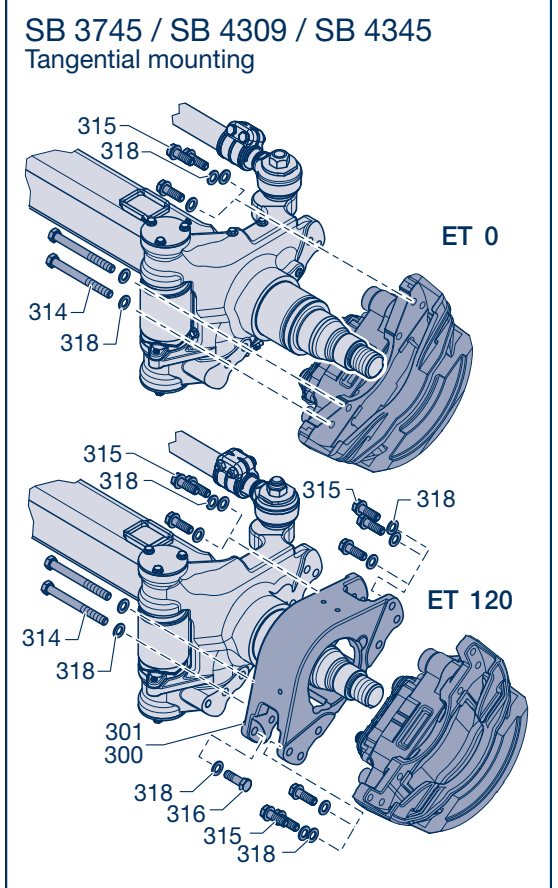
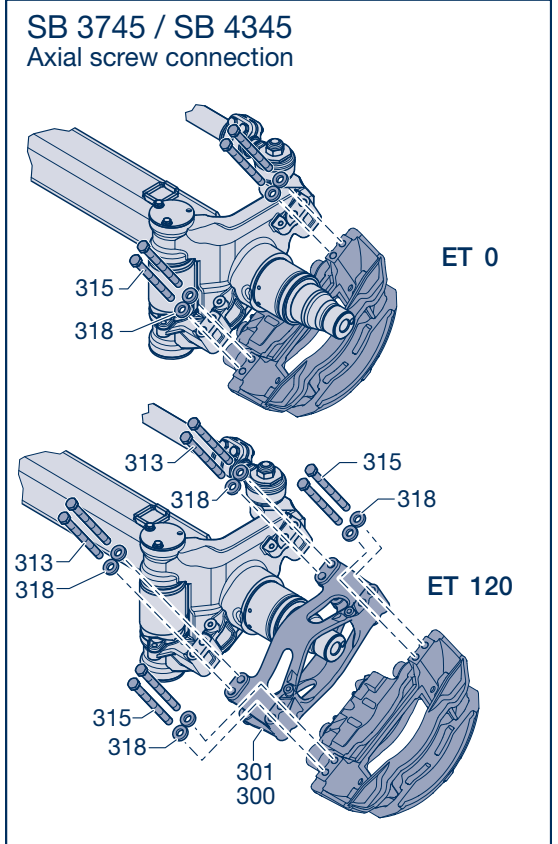
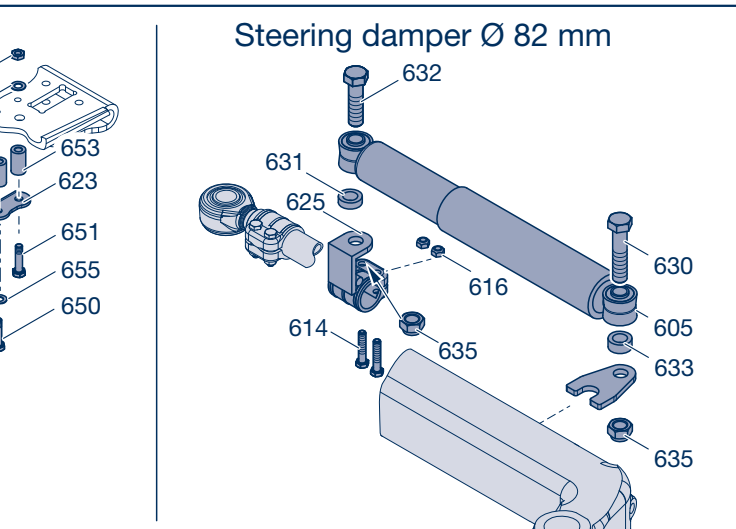
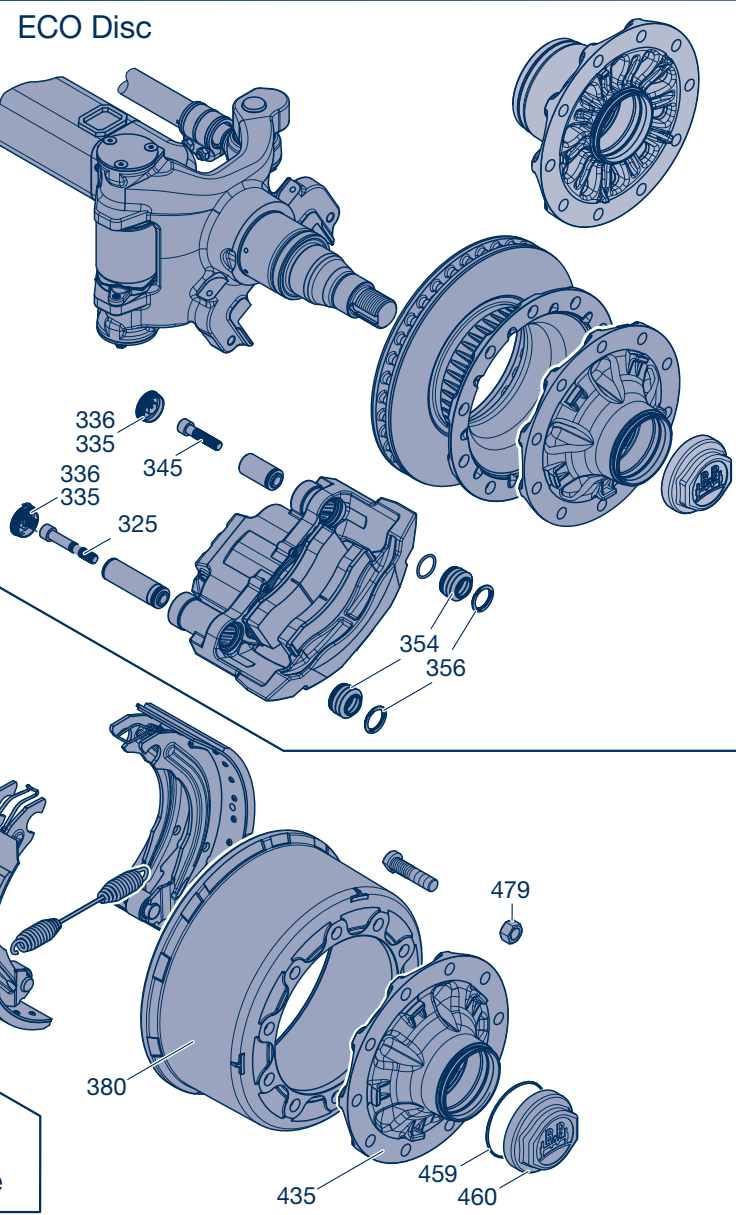

2 Name

Item	Name
10	Steering axle beam
17	Hexagon screw
18	Hexagon nut
23	Shaped plate (Packer)
40, 41	Steering pivot
42	Bush
52	Steering pivot
55	Thrust washer, upper
56	Thrust washer, lower
57	Seal (LL) Ring (L)
58	Cap
59	Pressure spring
60, 61	Roll pin
63, 64	Roll pin
70, 71	Steering lever
77	Closing plate
91	Lock cylinder
96	Bump stop (locking block)
98	Spring washer
99	Hexagon nut
190, 191	Booster bracket
194	Fastening bolt
195	Fastening bolt
196	Fastening bolt
198	Disc / Spring washer
199	Spring washer
435	Wheel hub
459	O-ring
460	Hubcap
479	Wheel nut
510	Fastening bolt

Track rod

Item	Name
150	Track rod
152	Tensioner head, left threaded
153	Tensioner head, right threaded
155	Bush (steel-rubber-steel)
160	Support (locking plate)
162	Clamp
163	Hexagon screw
164	Lock nut
171, 172	Thread bolt
173	Ring
175	Sleeve
178	Disc
184	Lock nut

Brake camshaft

Item	Name
210, 211	Bush
240	Brake camshaft, left
241	Brake camshaft, right
250	Locking ring
252	Ring
254	Ring
255	O-ring
256	O-ring
258	Sealing ring
262	Disc
266	Lever
268	Lock nut

Slack adjuster

Item	Name
280, 281	Slack adjuster
283	Cover
285, 286	Shaped plate
288	Locking screw
295	Return spring

Drum brake

Item	Name
65	Brake plate
67	Hexagon screw
199	Spring washer
215	Cover
216	Grease nipple
311	Brake bolt
312	Hexagon nut
314	Spring washer
315	Roll pin
325	Hooked spring ring
380	Brake drum
410, 411	Brake cylinder
501	Dust cover
502	Dust cover
503	Dust cover
504	Dust cover
564	Clamp
565	Drive pin

Disc brake

Item	Name
300, 301	Support
313	Screw
314, 315	Hexagon screw
316	Adjusting screw
318	Disc
325	Cylinder cap screw
335	Sealing cap
336	O-ring
345	Cylinder cap screw
354	Bellow
356	Ring

Steering damper

Item	Name
605	Steering damper
610	Clamp complete
614	Hexagon screw
615	Ring
616	Lock nut
618	Spring washer
620	Hexagon nut
623	Shaped plate
625	Shaped plate / Support
630	Hexagon screw
631	Ring
632	Hexagon screw
633	Ring
635	Lock nut
650, 651	Hexagon screw
653, 654	Sleeve
655	Spring washer
660	Hexagon nut

3 Safety regulations, safety information

3.1 Safety regulations

- All work must be performed by trained mechanics at competent repair facilities or authorised specialist companies who have access to all relevant tools and have acquired the know-how required for this work. Anyone who performs maintenance and repair work must be trained in automotive mechanics and already have experience in repairing trailers. Anyone who performs brake work must be trained in brake systems.
 - Comply with local safety regulations.
 - The relevant operation and service regulations as well as safety regulations of the vehicle manufacturer and of the manufacturers of other vehicle parts must be adhered to.
 - The vehicle must be prevented from moving during repair work. Please observe the relevant safety regulations for repair work on commercial vehicles, in particular the safety regulations for jacking up and securing the vehicle.
 - During repair work, make sure that the brake is not operated inadvertently.
 - Do not perform repair work unless wearing protective clothing (gloves, safety boots, safety goggles, etc.) and using the recommended tools.
 - Work on brake components removed from the vehicle must be carried out with the components fixed in place such as in a vice.
 - Only use recommended tools.
 - Handle brake calipers only at the sides when removing them to avoid crushing your fingers.
 - A second mechanic must provide assistance when working with heavy components (steering pivots, brake discs, brake drums or brake removal/installation).
 - All air lines and components must be depressurised before being removed.
 - Following each repair, perform a function check or a test drive in order to make sure that the brakes are functioning correctly. New brake linings only have maximum effect after a few braking actions. Avoid hard braking.
 - All exchanged components must be reused or disposed in accordance with the applicable environmental regulations, laws and directives.
 - The brake caliper with the clamping unit must not be opened. The mounting bolts of the cover as well as the pin in the area of the brake lever must not be unscrewed or released.
 - The remaining thickness of the brake lining and the condition of the brake disc or brake drum must be visually inspected at regular intervals with respect to the way in which the vehicle is used (see BPW maintenance instructions).
 - Tighten screws and nuts with the prescribed tightening torque.
 - The tyre valve must be positioned far enough away from the brake caliper to prevent it and the tyre from becoming damaged.
-

Safety information 3.2

This workshop manual contains different types of safety instructions, each of which is designated an icon and a key. The key word describes the severity of the potential danger.



Warning!

Possible potential danger of serious or fatal injury (severe injury or death).

Caution!

Possible dangerous situation (slight injury or damage to property).



Repair Guide!

Risk of damage to property or consequential damage if this information is not observed.



Note!

Application hints and especially useful information.

It is essential that all maintenance work is carried out in accordance with the prescribed intervals in order to maintain the safe operation and roadworthiness of the trailer. The relevant operation and service regulations of the vehicle manufacturer and of the manufacturers of other vehicle parts must also be adhered to.

Rectification of any defects which are discovered or replacement of worn parts should be carried out by a BPW Service Centre or BPW Direct Service Partner unless the vehicle owner has the facilities, equipment and workshop manuals and possesses an official certificate to perform interim inspections or special brake inspections.

When installing spare parts, it is strongly recommended that only original BPW components are used. Parts approved by BPW for trailer axles and suspensions regularly undergo special test procedures and as a result BPW is able to guarantee their quality.

However, BPW cannot assess every single third-party product as to whether it can be used for BPW trailer axles and suspensions without any risk to safety. This applies even if such products have already been tested by an accredited test authority.

The warranty becomes null and void if spare parts other than original BPW parts are used.

4 Tightening torques

Item	Description	Thread / spanner size	Tightening torque	
17	Steering pivot stop adjusting screw	M 20 x 70 / SW 30		
67	Screw-on brake plate fastening screw	M 16 x 1.5 / SW 24	174 Nm	
99	Retaining nuts of diaphragm cylinder for steering lock (LL)	M 12 x 1.5 / SW 19	86 Nm	
163	Hexagonal screws of clamps on track rod	M 12 / SW 19 M 12 x 1.5 / SW 19	86 Nm 86 Nm	
184	Lock nut of track rod (LL)	≤ 12 t ≥ 14 t	M 24 / SW 36 M 24 / SW 36	550 Nm 700 Nm
194	Fixing screws of steering lever (L)	M 16 / SW 24	285 Nm	
194	Fixing screws of brake cylinder base plate (LL)			
	Locking screws suspended	M 16 / SW 24	350 Nm with new parts 280 Nm	
	Locking screws upright top and suspended	M 16 - 10.9 / SW 24	230 Nm	
	Hexagonal screws	M 16 - 8.8 / SW 24	163 Nm	
	Locking screws upright top and suspended	M 14 / SW 19	148 Nm	
194	Fixing screws of closing plate for steering pivot bearing	M 16 - 10.9 / SW 24 M 16 - 8.8 / SW 24 M 14 / SW 19 M 10 - 10.9 / SW 15 M 10 - 8.8 / SW 15	230 Nm 163 Nm 148 Nm 53 Nm 38 Nm	
195	Fixing screws of adjustable brake cylinder base plate (L)	M 16 / SW 24	350 Nm with new parts 280 Nm	
268	Lock nut for slack adjuster	M 22 x 1.5 / SW 32	120 Nm	
288	Locking screws for shaped plate ECO-Master	M 8 / SW 13	28 Nm	
312	Brake bolt attachment hex nut	M 20 x 1.5 / SW 30	200 Nm	
313 - 316	Fixing screws of brake caliper or support			
	Axial screw connection, brake type SB 3745	M 16 x 1.5 / SW 24	300 Nm (280 - 330 Nm)	
	Axial screw connection, brake type SB 4345	M 18 x 1.5 / SW 27	420 Nm (400 - 460 Nm)	
	Tangential screw connection, brake type SB 3745, SB 4309, SB 4345	M 16 x 1.5 / SW 24	320 Nm (300 - 350 Nm)	
325 345	Fixing screws of brake caliper, brake type ECO Disc	M 16 x 1.5 / SW 14	260 Nm (250 - 270 Nm)	
335	Sealing cap for caliper mounting, brake type ECO Disc	M 49 x 1.5 / SW 14	15 Nm (15 - 20 Nm)	
410 411	Attachment nuts for brake cylinder	M 16 x 1.5 / SW 24	180 Nm (180 - 210 Nm)	
510	Locking screws on cover plates	M 10 / SW 13 M 10 / SW 15	43 Nm	
511	Self-tapping screw for sensor holder	M 8 / SW 13	25 Nm	
614	Fixing screws of clamp for steering damper	M 10 / SW 17	74 Nm	
630 632	Fixing screws of steering damper Ø 32 mm	M 10 / SW 17	26 Nm	
632	Fixing screws for steering damper Ø 82 mm	M 12 / SW 19 M 24 / SW 36	86 Nm 425 Nm	
650	Fixing screws of moulded plate for steering damper	M 12 / SW 19	43 Nm	

Spezialwerkzeug 5

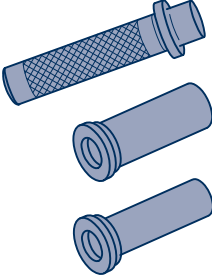
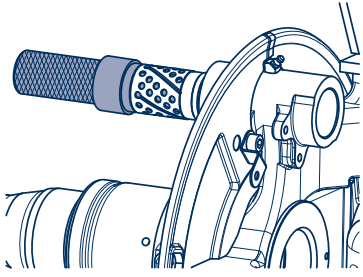
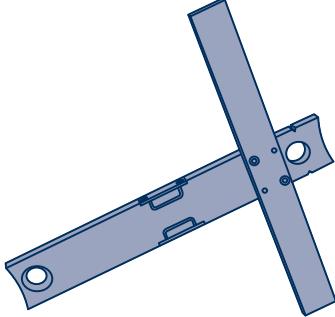
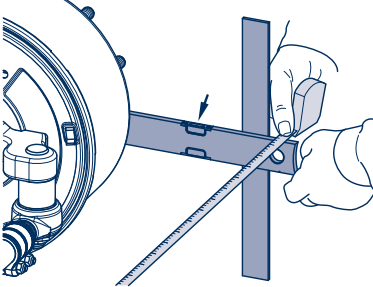
Number	Description	Illustration of tool	Tool in operation
1	Driving mandrel complete for bearing bushes (camshaft and brake pins) BPW code number: 05.001.04.04.0		
2	Measuring tools (set of 2) for tracking check BPW code number: 99.00.000.7.75		

6 Lubrication intervals

- Steering axles with drum and disc brake

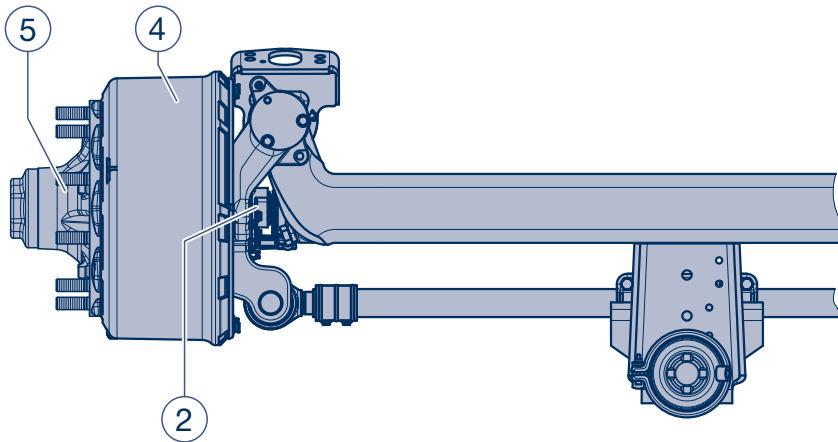

Steering axle, series LL with drum brake

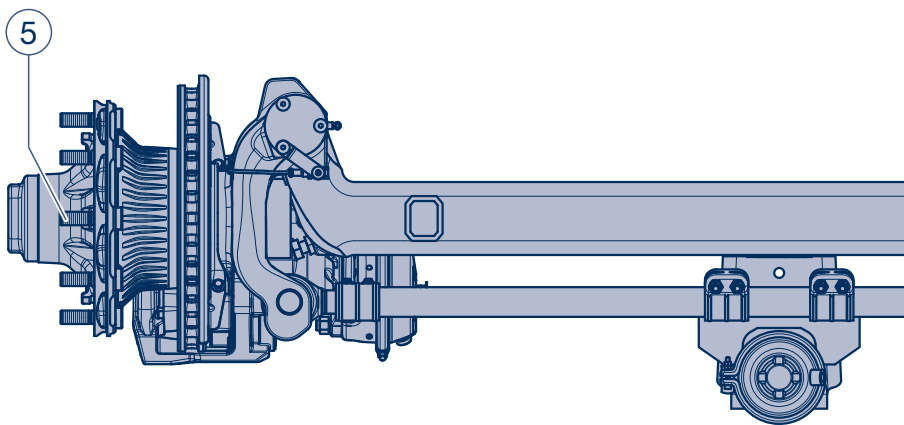
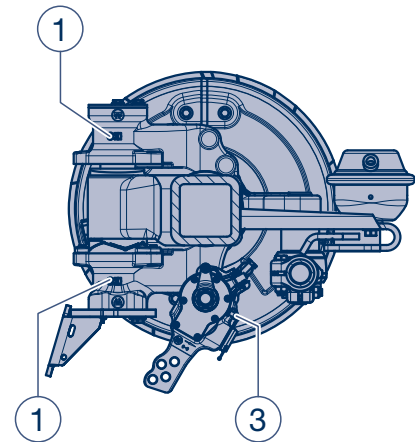

Steering axle, series LL with disc brake

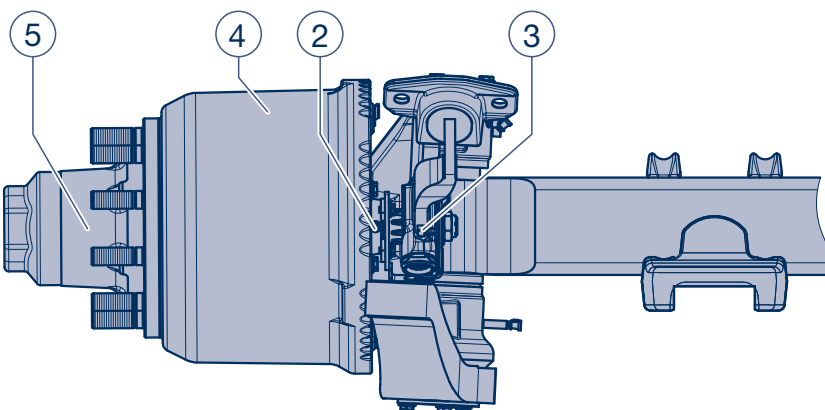
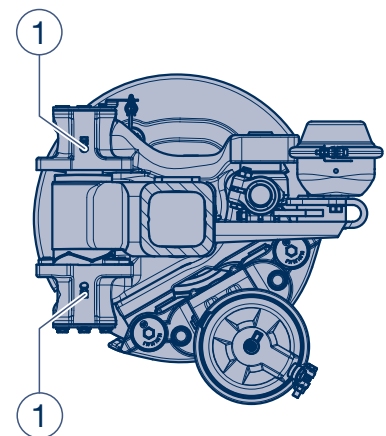

Steering axle, series L with drum brake

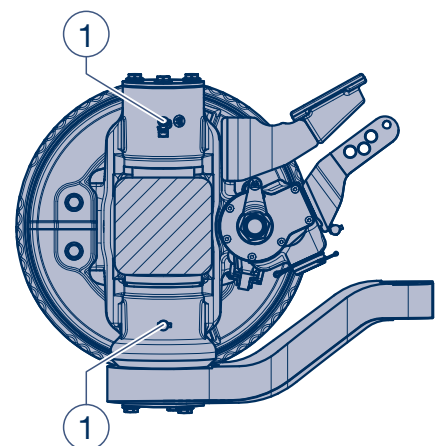

Lubrication Overview For detailed descriptions please see the maintenance instructions or the workshop manual for the respective rigid axles.	every 6 weeks ²⁾	every 12 weeks	every 26 weeks ¹⁾²⁾	at every brake lining replacement ²⁾		annually	 BPW recommendation. Does not affect warranty		every 3 years	after 5 years, thereafter every 3 years
				latest annually ¹⁾	latest every 2 years		every 2 years	latest every 3 years or min. every 500,000 km ²⁾		
① Steering knuckle bearing, top and bottom	①									
② Brake camshaft bearing, outer and inner										
On-road conditions				②						
Off-road conditions			②							
Outside Europe			②							
③ Slack adjusters manual		③								
Slack adjuster ECO-Master:										
On-road conditions				③						
Off-road conditions			③							
Outside Europe			③							
④ Brake shoes with closed anchor eye					④					
⑤ ECO Plus 3, ECO Plus 2 and ECO ^{Plus} Unit:										
On-road conditions										⑤
Off-road conditions									⑤	
Outside Europe								⑤		
On-road conditions								⑤		
Off-road conditions							⑤			
ECO Unit									⑤	
Inside Europe									⑤	
Outside Europe							⑤			
Conventional hub bearing				⑤						

For the positions ① to ③ the use of a high-pressure central lubrication system which is capable of feeding special longlife grease of consistency class 2-3 is permissible. The use of liquid lubricants is not permitted!

¹⁾ After a long idle period, prior to initial operation actuate the brake lever and lubricate the brake camshaft bearing.

²⁾ If used under extreme conditions (e.g. extreme off-road use) more frequent lubrication with high pressure grease is necessary.

7 Maintenance intervals

- Steering axle with drum brake

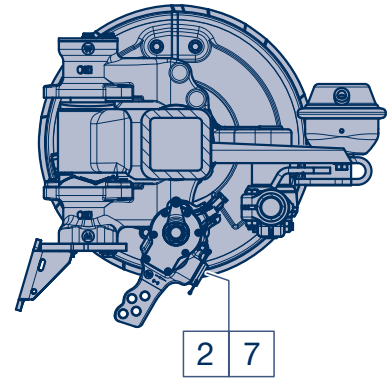
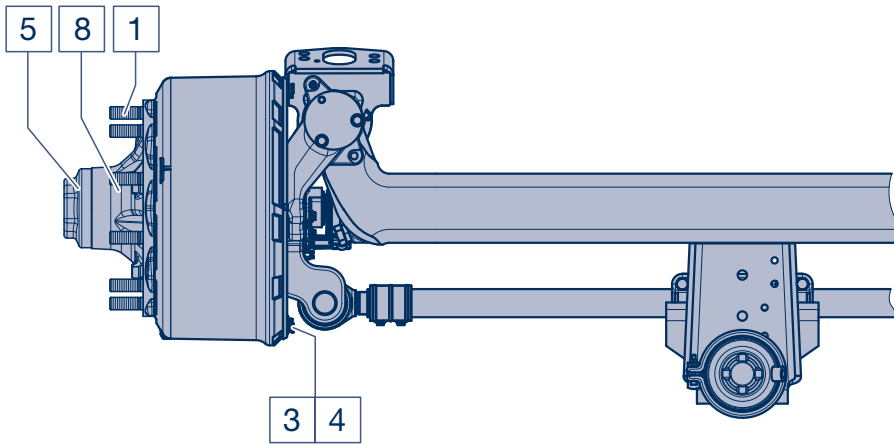

Steering axle, series LL with drum brake

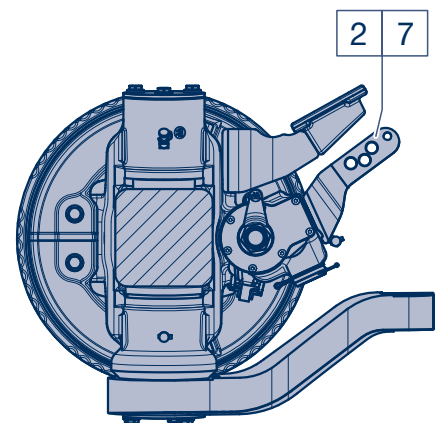
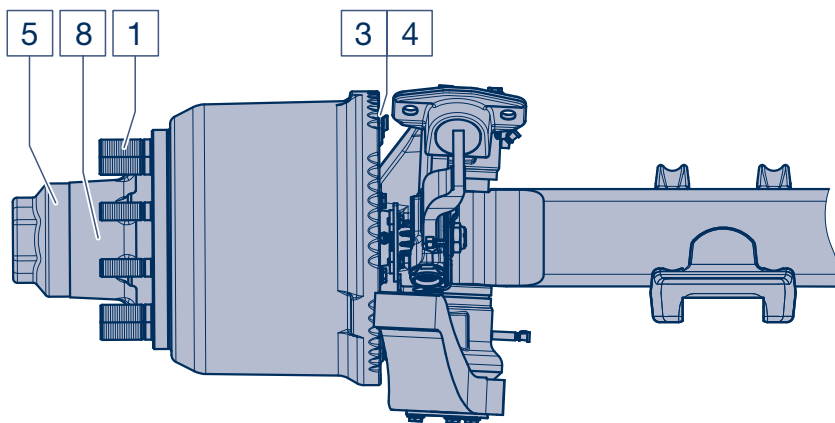
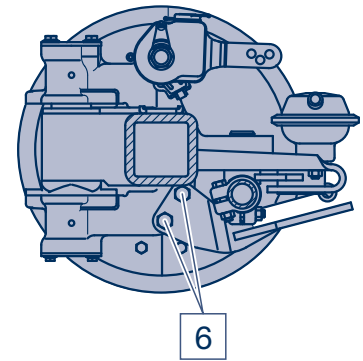

Steering axle, series L with drum brake

Maintenance work and operation check						
Overview		initially	every 1 to 3 weeks	every 12 weeks	every 26 weeks ²⁾	at every brake lining replacement, latest annually ²⁾
For detailed descriptions please see the maintenance instructions or the workshop manual for the respective rigid axles						
1	Check wheel nuts for tightness.	1 ¹⁾				
2	With manual slack adjusters, check brake play, adjust if necessary to 10 - 12% of the connected brake lever length and activate by hand or with 0.5 - 0.8 bar. (Not applicable in the case of automatic slack adjusters.)		2			
-	Check the tyres for uneven wear, adjust the inflation pressure if necessary according to the manufacturer's specifications.			-		
3	Check brake lining thickness is at least 5 mm (SN 300 min. 7 mm).			3		
4	Check brake drum for cracks and check the internal diameter.			4		
5	Check caps for firm seating. (Not necessary with ECO Plus 3, ECO Plus 2 and ECO ^{Plus} axles).				5	
6	Check the fixing screws of the suspended brake cylinder base plates for firm seating.				6	
7	Check operation of automatic slack adjusters.					
	For use inside Europe				7	
	For use outside Europe			7		
o	Visual inspection of all component parts and welding seams for damage and wear.					
	For use inside Europe				o	
	For use outside Europe			o		
8	Check wheel hub bearing play, adjust if necessary.					
	ECO Plus 3, ECO Plus 2 and ECO ^{Plus} Unit					8
	ECO Unit, conventional bearing				8	

¹⁾ After the first run under load conditions, likewise after each wheel change.

²⁾ Under extreme conditions, increase frequency (e.g. construction sites and poor roads).

8 Maintenance intervals

- Steering axles with disc brakes

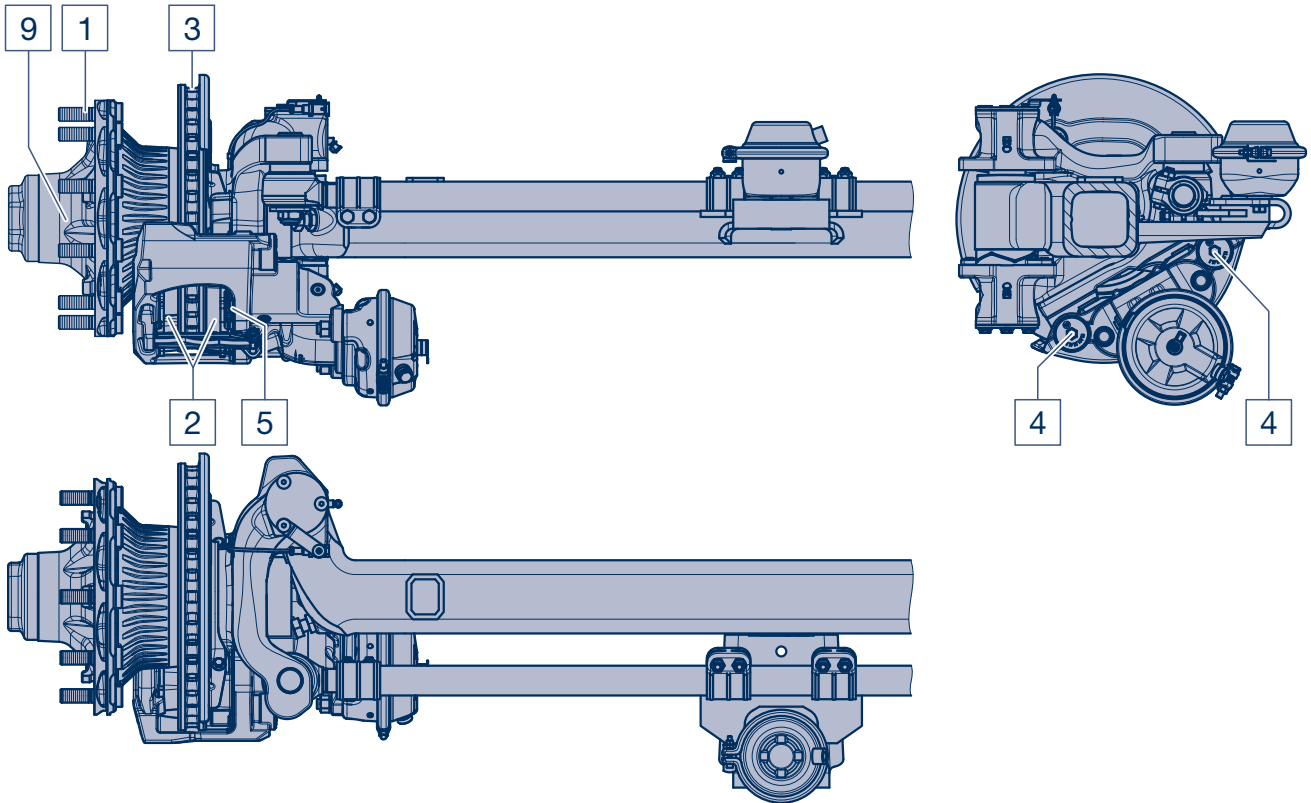

Steering axle, series LL with ,ECO Disc' disc brake, brake type TSB

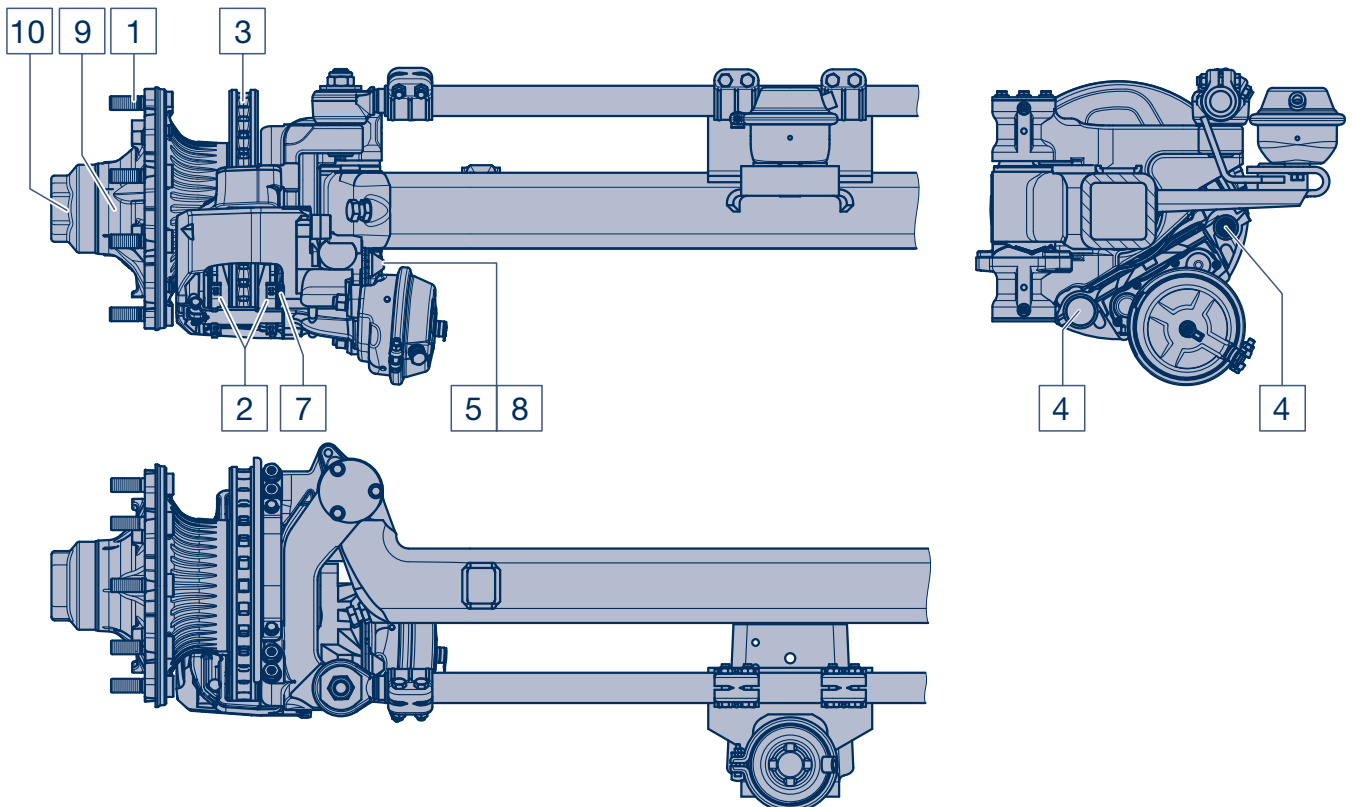

Steering axle, series LL with disc brake, brake type SB

Maintenance work and visual inspection Overview For detailed descriptions please see the maintenance instructions or the workshop manual for the respective rigid axles.	initially	every 12 weeks ²⁾	every 26 weeks ²⁾	at every brake lining replacement, latest annually
1 Check wheel nuts for tightness.	1 ¹⁾			
2 Check brake pad thickness.		2		
- Check the tyres for uneven wear (Brake type SB).		-		
o Visual check, check all components and welding seams for damage, wear and corrosion.			o	
3 Check brake disc thickness and visually check for cracks. For use inside Europe			3	
For use outside Europe		3		
4 Check caliper guide system. For use inside Europe			4	
For use outside Europe		4		
5 Check brake adjustment (Brake type SB). For use inside Europe			5	
For use outside Europe		5		
6 Check coarse dirt seals at the pressure plates (Brake type TSB). For use inside Europe				6
For use outside Europe			6	
7 Check bellows on the guide pins (Brake type SB). ECO Plus 2 and ECO Plus axles for use inside Europe				7 ²⁾
ECO Plus 2 and ECO Plus axles for use outside Europe, ECO axles and axles with conventional hub bearing			7	
8 Check caliper unit (Brake type SB). ECO Plus 2 and ECO Plus axles for use inside Europe				8 ²⁾
ECO Plus 2 and ECO Plus axles for use outside Europe, ECO axles and axles with conventional hub bearing			8	
9 Check wheel hub bearing play, adjust if necessary. ECO Plus 3, ECO Plus 2 and ECO ^{Plus} Unit				9 ²⁾
ECO Unit, conventional hub bearing			9	
10 Check caps for tightness (not necessary with ECO Plus axles).			10	

¹⁾ After the first run under load conditions and likewise after each wheel change

²⁾ Under extreme conditions, increase frequency (e.g. off-road, heavy duty braking work).

9 Steering axles with drum brakes

9.1 Manual slack adjuster (GSK)

Removal

- [1] Prevent the vehicle from rolling away.
Release the service brakes and the handbrake.
- [2] Unhook the tension spring (295) in the slack adjuster (280, 281).
- [3] Remove the pin from the brake cylinder (410, 411) fork head.

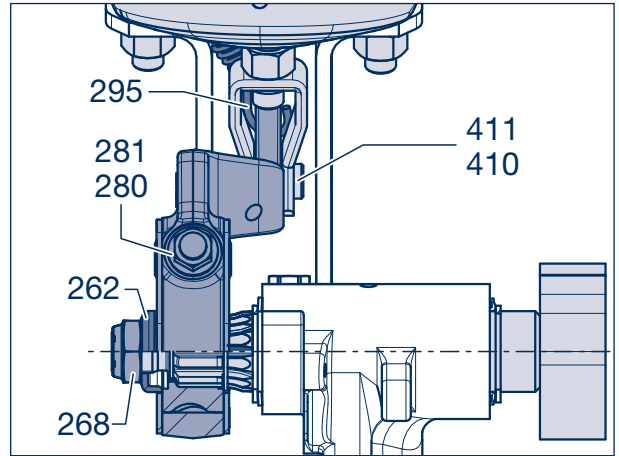

Picture 1



Note:

If the base plate (190, 191) is fitted above the steering pivot (52), unscrew the retaining nuts (SW 24) on the brake cylinder (410, 411).

Turn back the slack adjuster (280, 281) with the adjusting hexagon (arrow) until the pin in the fork head of the brake cylinder can be removed.

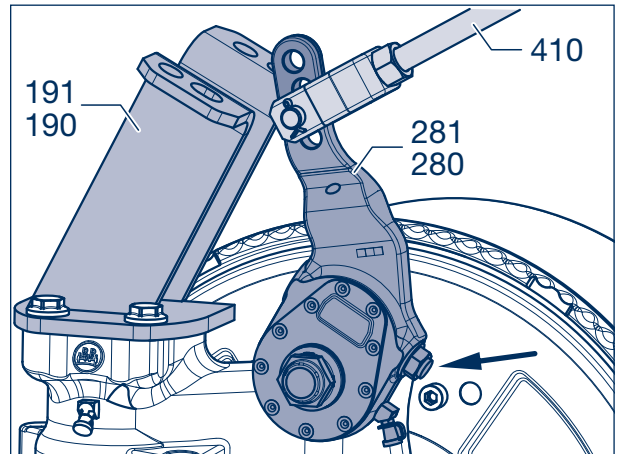

Picture 2

- [4] Unscrew the lock nut (268, SW 32), remove the washer (262) and slack adjuster (280, 281).

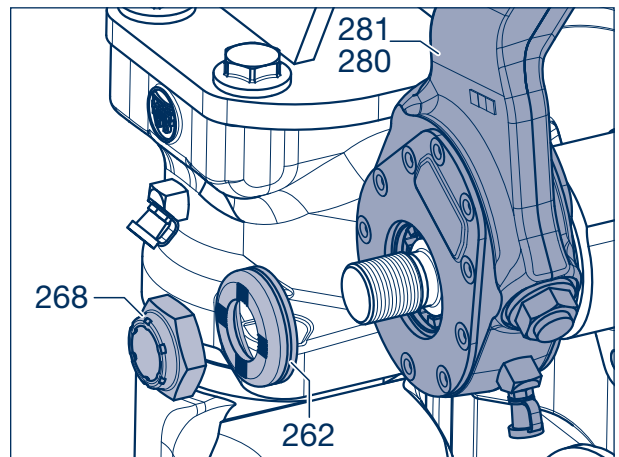

Picture 3

Installation

- [5] Smear the teeth of the brake camshaft (240, 241) with BPW special longlife grease ECO-Li^{Plus}.
- [6] Slide the slack adjuster (280, 281) onto the brake camshaft.
- [7] Fit the washer (262) with the dished side facing the slack adjuster and a new lock nut (268, SW 32) tightened to the specified torque of 120 Nm.

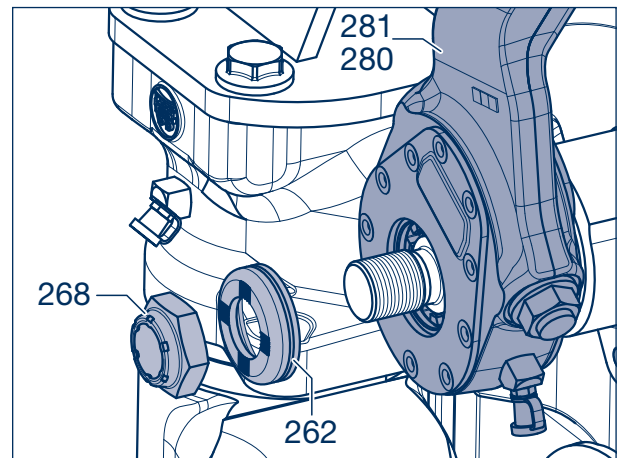

Picture 4

- [8] Align the slack adjuster with the brake cylinder fork head using the adjusting hexagon.
- [9] Fit and secure the pin. Insert the return spring (295) with lever lengths of 150 - 195 mm.

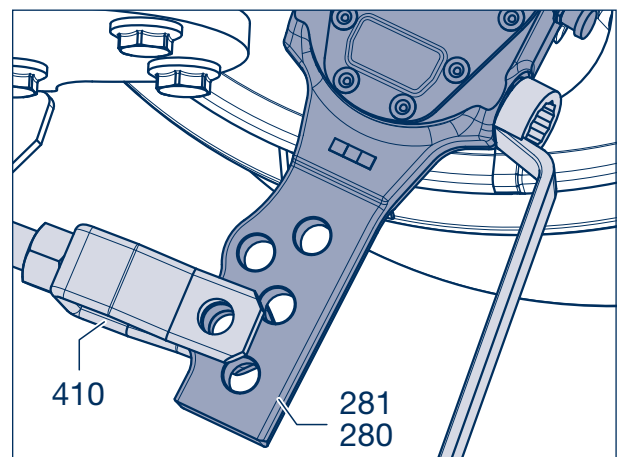

Picture 5



Note:

If the base plate (190, 191) is fitted above the steering pivot, first fit the brake cylinder fork head (410) on the slack adjuster and secure it. Turn the slack adjuster (280, 281) with the adjusting hexagon to the correct position until the brake cylinder rests on the base plate. Adjust the brake cylinder to the brake lever length and screw it onto the base plate.

Tightening torque:
180 Nm (180 - 210 Nm)

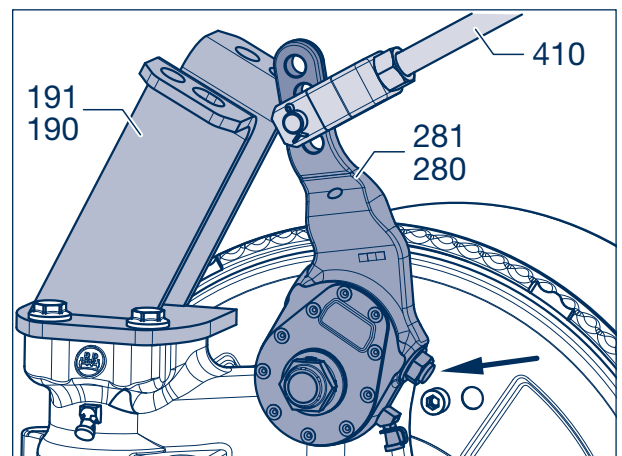

Picture 6

9 Steering axles with drum brakes

- [10] Actuate the slack adjuster (280, 281) by hand in the direction of pressure. Adjust slack „a” to 10 - 12 % of the connected brake lever length „B”, e.g., lever length 150 mm = 15 - 18 mm of slack.
- [11] Grease all lubrication points with BPW special longlife grease ECO-Li^{Plus}.

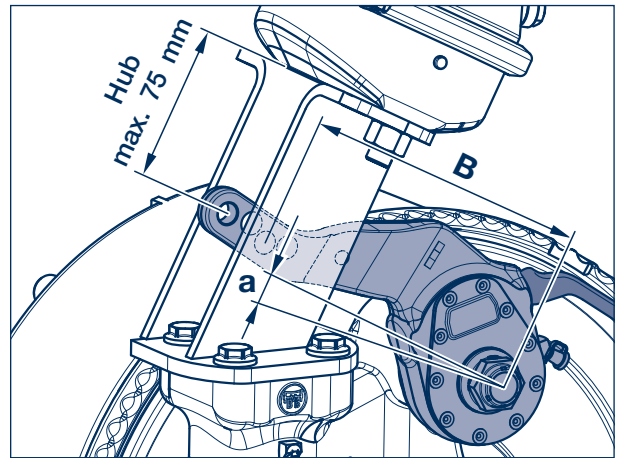

Picture 7

9.2 Automatic slack adjuster (ECO-Master)

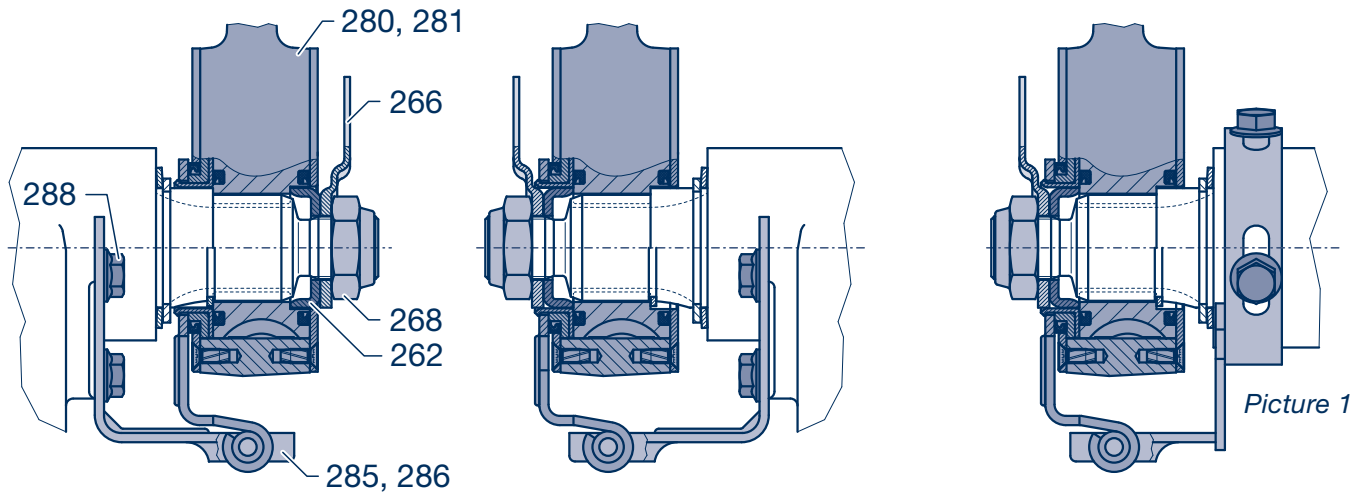

☞ For disassembly see manual slack adjuster on page 22.

Installation

- [1] Smear the teeth of the brake camshaft (240, 241) with BPW special longlife grease ECO-Li^{Plus}.
- [2] Loosen the safety screws of (288, SW 13) the shaped plate (285, 286) somewhat or - if disassembled - lightly screw them back in.
- [3] Slide automatic slack adjuster ECO-Master (280, 281) onto the brake camshaft (240, 241). Fit yoke of the reaction bracket (285, 286) onto control lever (arrow) (not left and right positions).
- [4] Fit washer (262) and wear lining indicator (266) pointing vertically upwards, and new lock nut (268, SW 32) and tighten to 120 Nm.

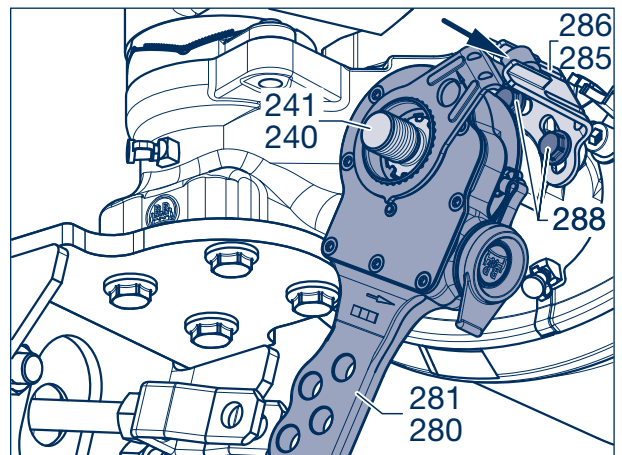

Picture 2

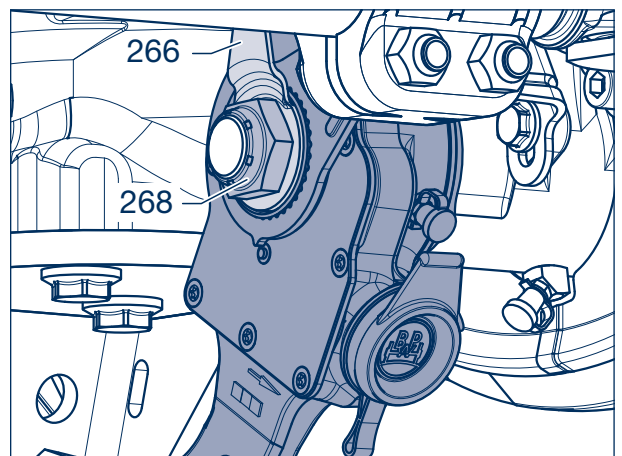

Picture 3

9 Steering axles with drum brakes

- [5] Remove cap (283), press down clutch sleeve with ring spanner (arrowed) and, by turning to left or right, align the bolt hole in brake lever with round hole or end of slot in the yoke.

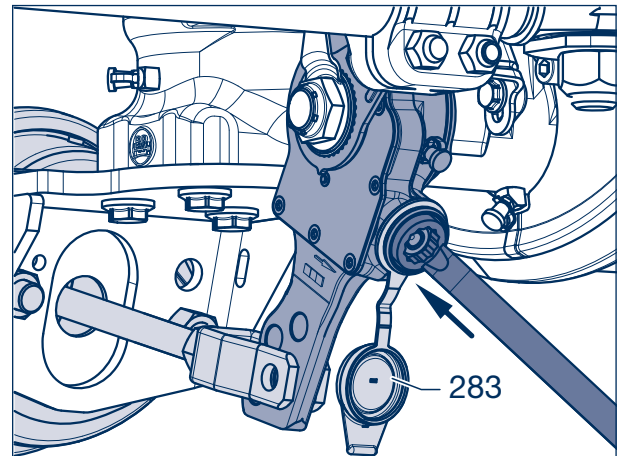

Picture 4



Note:

If the base plate (190, 191) is fitted above the steering pivot (52), first fit the brake cylinder (410, 411) fork head on the slack adjuster (280, 281) with the pin and secure it. Turn the slack adjuster with the adjusting hexagon to the correct position until the brake cylinder rests on the base plate. Adjust the brake cylinder to the brake lever length and screw it onto the base plate.

Tightening torque:
180 Nm (180 - 210 Nm)

The brake cylinder piston must not be pulled out and the brake must remain in the released position.

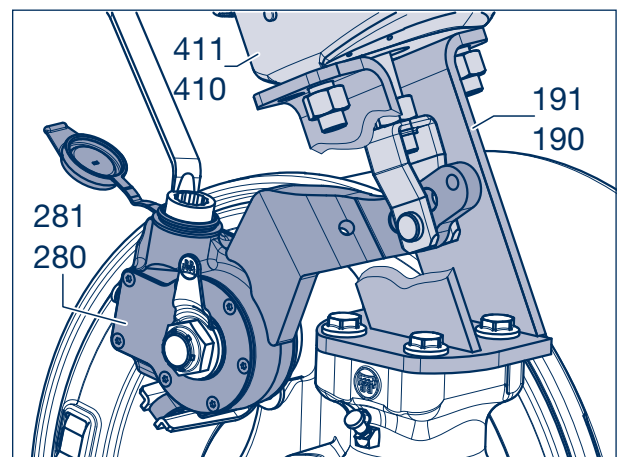

Picture 5

- [6] Insert clevis pin and lock.
[7] Insert return spring (295).



Note:

The outer return spring is no longer required on BPW brake cylinders with round-hole fork heads.

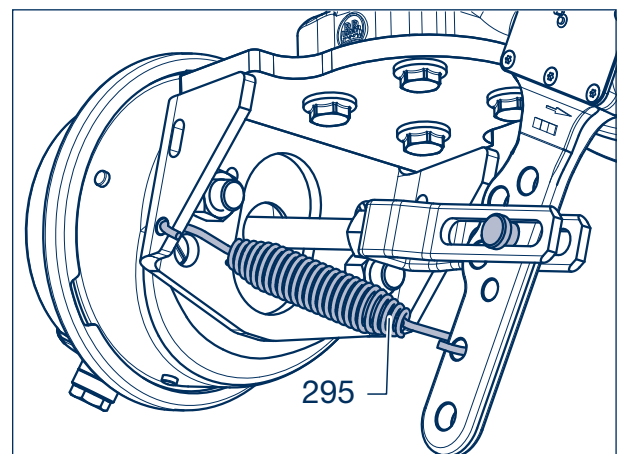

Picture 6

- [8] Holding the clutch sleeve down, press control lever and reaction bracket (285, 286) in the direction of the arrow until it reaches the endstop.
- [9] The lug on the control lever will now point to the control point.
- [10] Screw on the reaction bracket (285, 286) to the steering box with two locking nuts M 8 x 12 (288, SW 13).

Tightening torque: $M = 28 \text{ Nm}$



Repair guide!

Ensure the correct screw length when exchanging the screws (288).



Repair guide!

Control lever lug must align to the control point after tightening up!
(Basic setting)

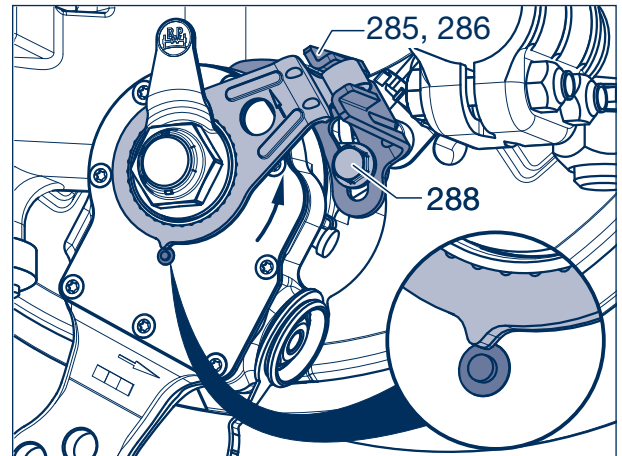

Picture 7

Adjusting the brake:

- [11] Set play „a” to 10 - 15 % of the connected brake lever length „B” by turning the adjusting hexagon (keep clutch sleeve pressed down), eg. if brake lever length 150 mm = play 15 - 22 mm.
- [12] When the brake is applied, the cylinder push rod and slack adjuster must be at an angle of approximately 90° to each other.
- [13] Grease all points with BPW special longlife grease ECO-Li^{Plus}.
- [14] Fit plastic cap (283).



Repair guide!

The setting of the ECO-Master must be readjusted after a change or renewal of the brake cylinder, brake camshaft or the automatic slack adjuster.

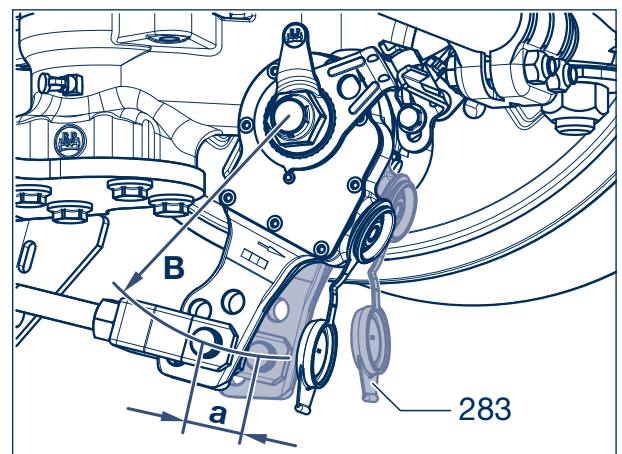

Picture 8

9 Steering axles with drum brakes

9.3 Brake camshaft

Removal

- [1] Remove the wheel/hub unit and brake shoes: see the workshop manuals for the corresponding rigid axles.
- [2] Unscrew the lock nut (268, SW 32) from the brake camshaft (240, 241). Pull off the slack adjuster (281).
- [3] If needed, remove the locking ring (250) from the nut of the brake camshaft and remove with sealing ring (258).
- [4] Withdraw the brake camshaft from its bearing.

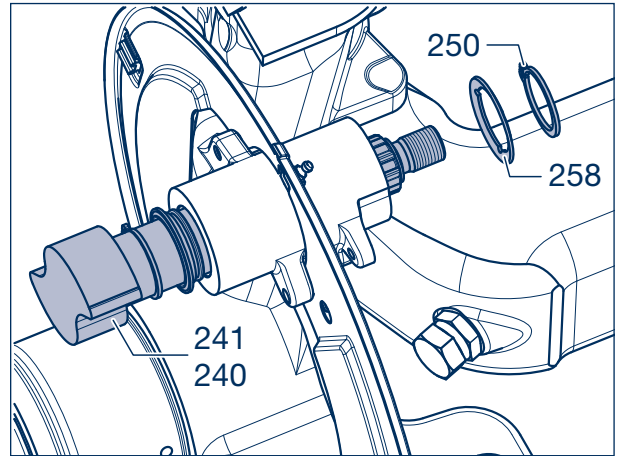

Picture 1

- [5] Remove the sealing washers (252, 255, 256) from the brake camshaft and fit new ones.
- [6] Check bush (210, 211) in brake anchor plate and, if necessary, change bush (max. bearing play 0.8 mm).
- [7] Drive in new outer bush (210) with mandrel (BPW no. 05.001.04.04.0), with the ring groove (arrowed) pointing towards the grease nipple.
- [8] On the outside, the bush must stand back $7.2 + 0.5$ mm. Only apply light strokes when driving in and out; apply counterpressure to brake anchor plate if necessary.

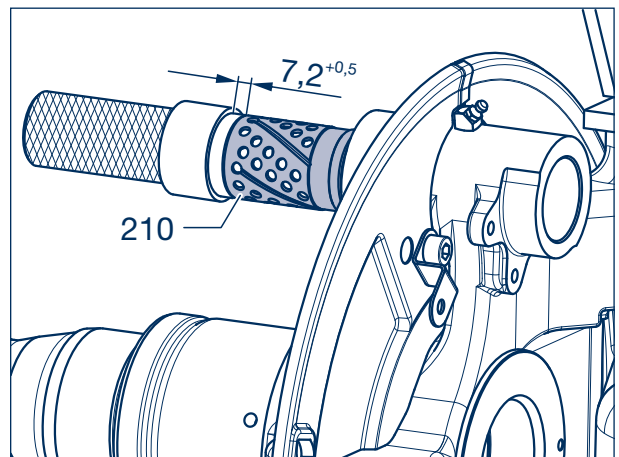

Picture 2

- [9] Firmly drive the new inner short bush (211) into the brake carrier. Only work with gentle taps, if necessary holding the brake carrier.
- [10] Check the brake camshaft (240, 241) movement in the bushes for smoothness. If necessary, re-work the bushes.

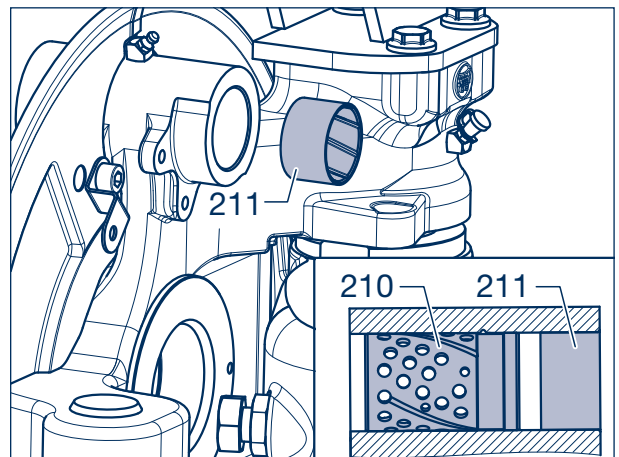

Picture 3

Installation

Series H/K:

[11] Insert circlip (250) into the groove, push combined seal (252) and O-ring (256) (green, Ø 40 x 2.5) up to the bearing seat.

☞ Continue with working step [13].

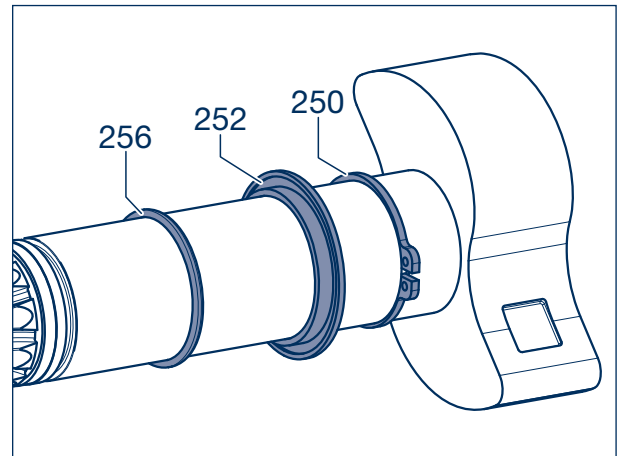

Picture 4

Serie N:

[12] Slide ring (254) and O-ring (256) onto the bearing.



Repair guide!

On brake camshaft bearings with 300 mm dia. S-cam brake, the circlip (250) and combined seal (252) are dispensed with. The brake camshaft pushes against the S-cam which is directly on the rear of the brake carrier housing.

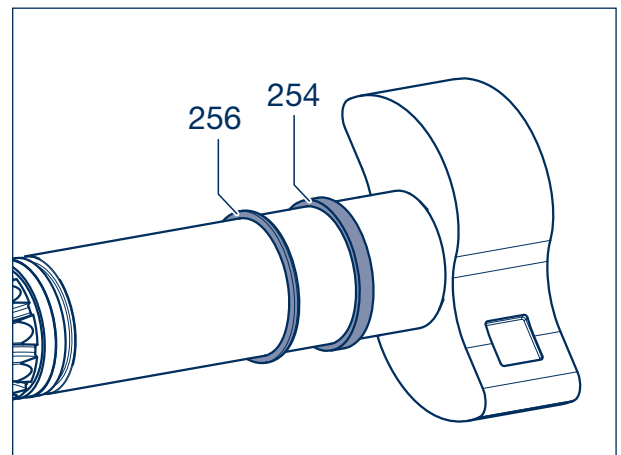

Picture 5

[13] Grease bearing with BPW special longlife grease ECO-Li^{Plus}.

[14] Place the O-ring (255) (black, dia. 34 x 4 with a groove width of 4.5 mm or dia. 37 x 2.6 with a groove width of 3.4 mm) in the groove (arrow).

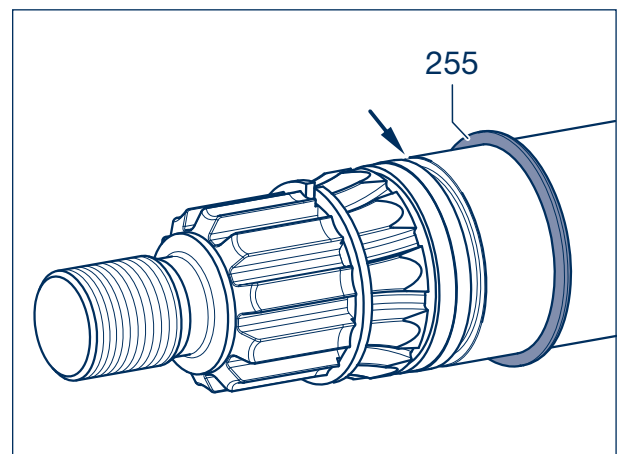

Picture 6

9 Steering axles with drum brakes

- [15] Insert the brake camshaft (240, 241) into the brake carrier.
- [16] Slide the sealing ring (258) on with concavity pointing towards the axle center (not applicable for steering axles series L with brake SN 300).
- [17] Place the circlip (250) in the groove.

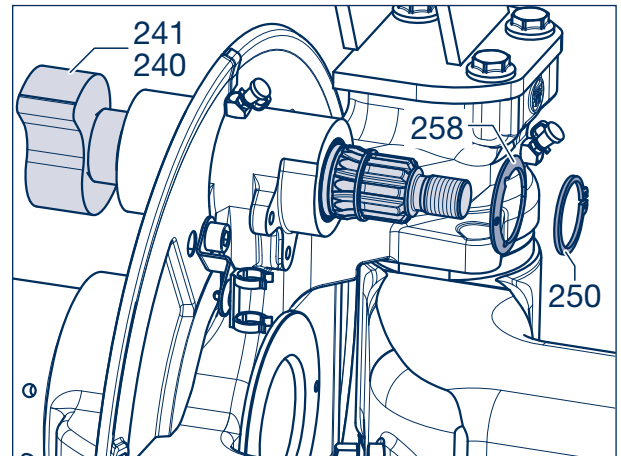

Picture 7

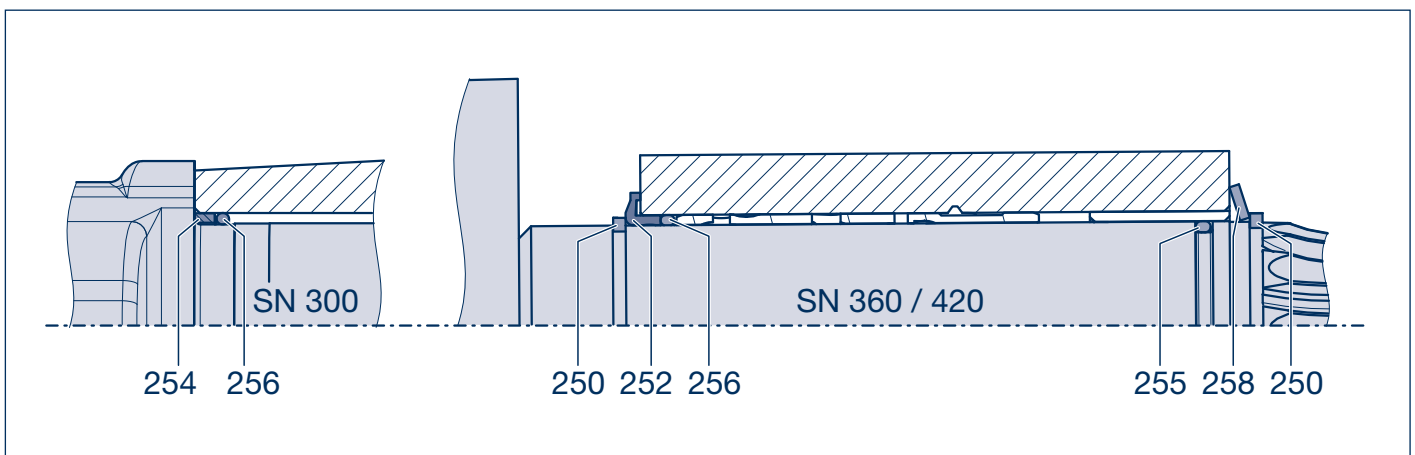

Picture 8

9.4 Booster brackets

Removal

- [1] Take the brake cylinder (410, 411) off the base plate (190, 191).
- [2] Unhook the tension spring (295), if available.
- [3] Unscrew the fixing screws (194, 195, 196) depending on design) from the base plate (190, 191). Remove the base plate.



Caution:
On steering axles of the „LL” series,
if the base plate is fitted above the
steering pivot, there is a compression
spring below it.

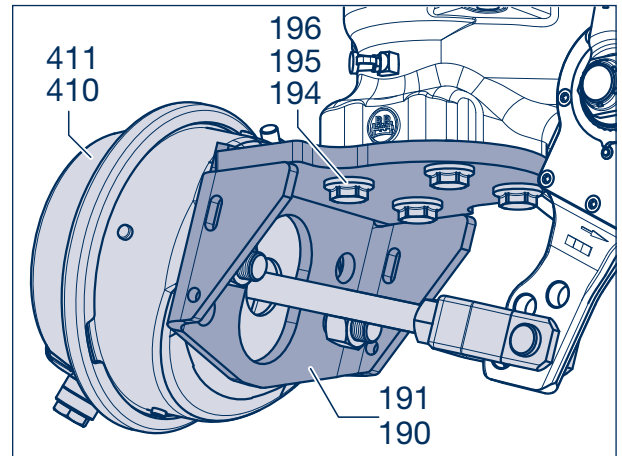

Picture 1

Installation

Air cylinder bracket under the steering pivot

- [4] Position the air cylinder bracket (190, 191) in the correct position under the steering housing.
- [5] Tighten the air cylinder bracket with securing bolts (194, 195, 196) and possibly spring washers (198) evenly and alternately, using the specified torque.

Tightening torque:

Locking screw

M 14 - 10.9 / SW 19 M = 148 Nm

M 16 - 10.9 / SW 24 M = 230 Nm

Hexagonal screw with spring washer

M 14 - 10.9 / SW 19 M = 148 Nm

M 16 - 8.8 / SW 24 M = 163 Nm

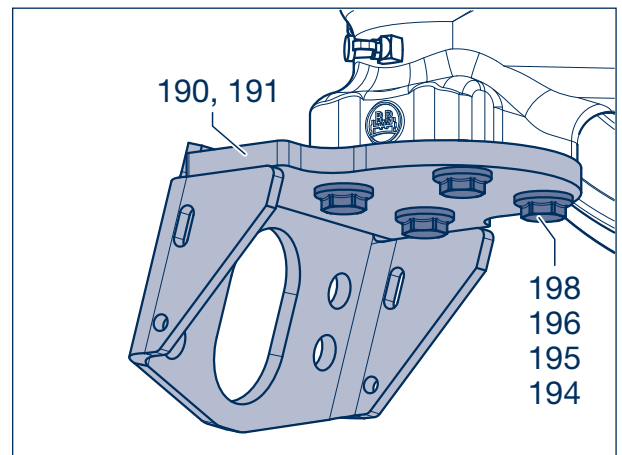

Picture 2

☞ Continue with working step [7].

Base plate above the steering pivot

- [4] With the LL model series, coat the upper and lower contact surface of the pressure springs (59) with grease and insert into the hole of the steering bolt (52).

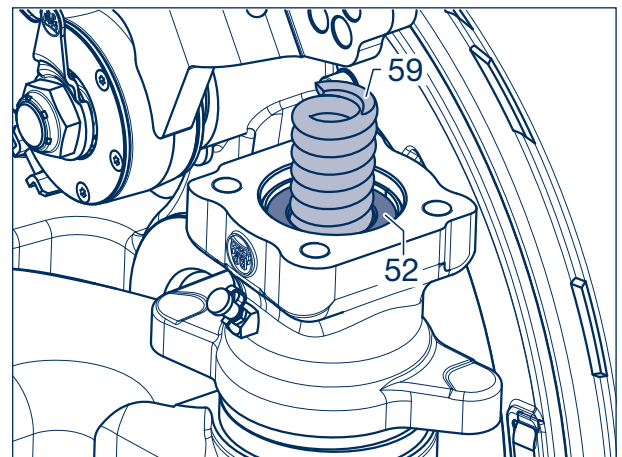

Picture 3

9 Steering axles with drum brakes

- [5] Place the base plate (190, 191) in its correct position on the steering box or on the compression spring (52).
- [6] Tighten the air cylinder bracket with securing bolts (194, 195) and possibly spring washers (198) evenly and alternately, using the specified torque.

Tightening torques:

Locking screw
M 16 - 10.9 / SW 22 M = 230 Nm

Cylinder or hexagon bolt with spring washer
M 16 - 8.8 / SW 12, SW 24 M = 163 Nm

 Continue with working step [7].

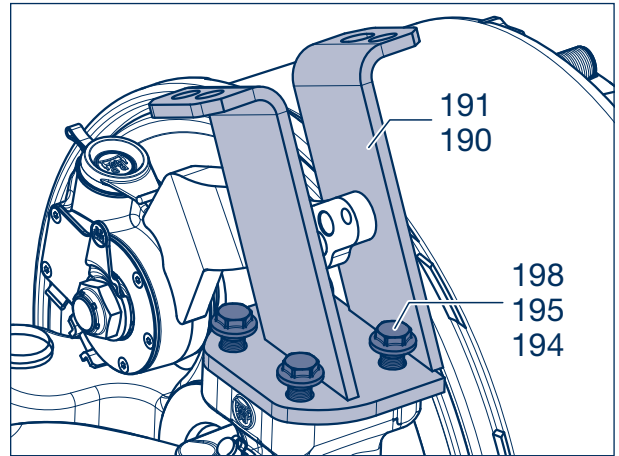

Picture 4

Air cylinder bracket next to steering pivot

- [4] Screw the air cylinder bracket (190, 191) to the steering housing, using two safety bolts M 16 (195, SW 24).



Repair guide!

In the case of steering housing with counterbored surfaces (arrows), washers (198) must be fitted between the base plate and the steering housing.

If the mating surfaces are raised, no washers should be fitted.

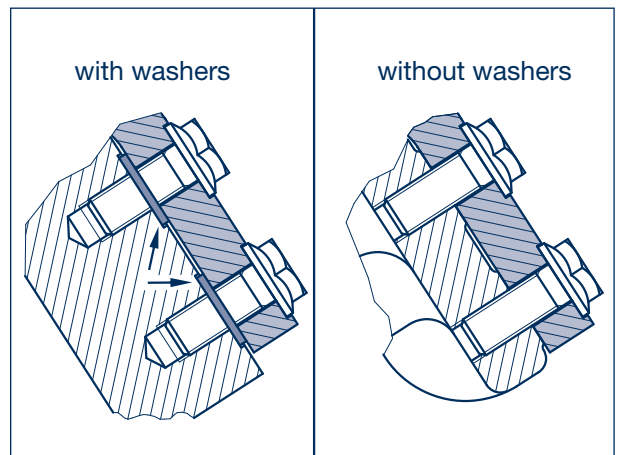

Picture 5

-  For series L steering axles with air cylinder bracket (190, 191) mounted next to the steering pivot, discs (198) must be mounted between the air cylinder bracket and the installation plate. Install two safety screws M 16 x 45 (195, SW 24).

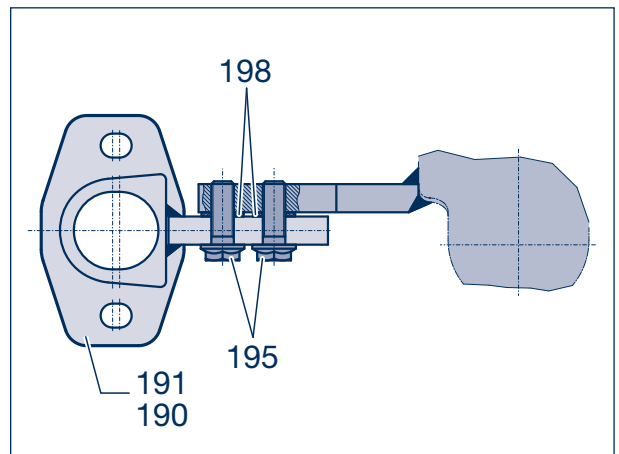

Picture 6

- [5] Pretension both safety screws to 150 Nm.
- [6] Tighten safety screws (196, SW 24) with the specified tightening torque of 280 Nm or in case of new parts to 350 Nm.

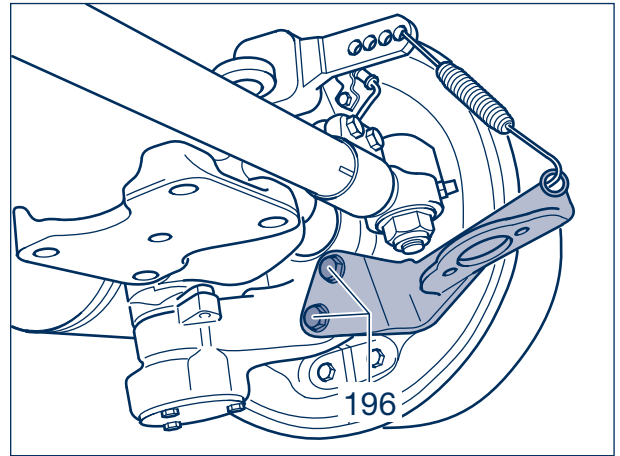

Picture 7

All air cylinder brackets

- [7] Fit the brake cylinder (410, 411) (see also installation instructions for the slack adjuster, chapter 9.1 and 9.2).
For mounting of the air cylinder bracket next to the steering housing the push rod length is 280 mm (push rod extension required).
- [8] Fit on the mounting nuts until tight.
- [9] Tighten alternative sides to **180 Nm** (180 - 210 Nm) using a torque wrench.
- [10] Insert the tension spring (295).

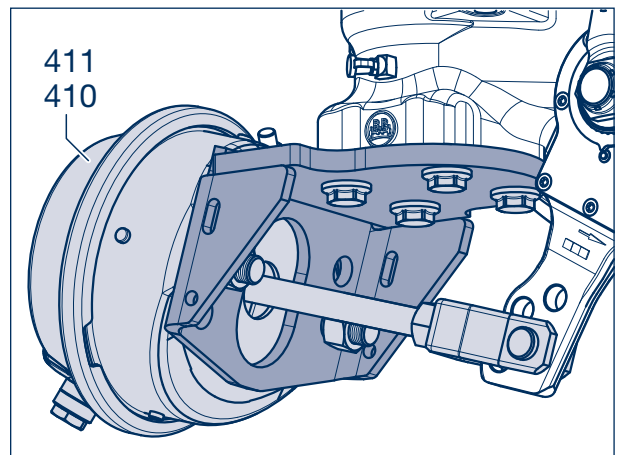

Picture 8



Note:
The outer return spring is no longer required on BPW brake cylinders with round-hole fork heads.

- [11] Readjust the brake installation instructions for the slack adjuster, chapter 9.1 and 9.2).

9 Steering axles with drum brakes

9.5 Brake bolt

For quick-release brake shoes

Removal

- [1] Remove the wheel/hub unit and brake shoes, see the workshop manuals for the corresponding rigid axles.
- [2] Disassemble upper and lower or left and right dust cover (501, 502, 503, 504).
- [3] Check hooked spring rings (325) on the brake bolt (311) for wear and position and replace, if necessary.



Repair guide!
Hooked spring rings (325) must be renewed at the latest when the brake lining is changed, if not before.

- [4] Use a hammer to drive the brake bolt (311) out of the brake anchor plate. The roll pin (315) in the brake anchor plate/brake bolt hole must shear off when doing this (arrow). Brace the brake anchor plate if necessary.
- [5] Drive the remnants of the roll pin (315) out of the hole in the brake anchor plate.

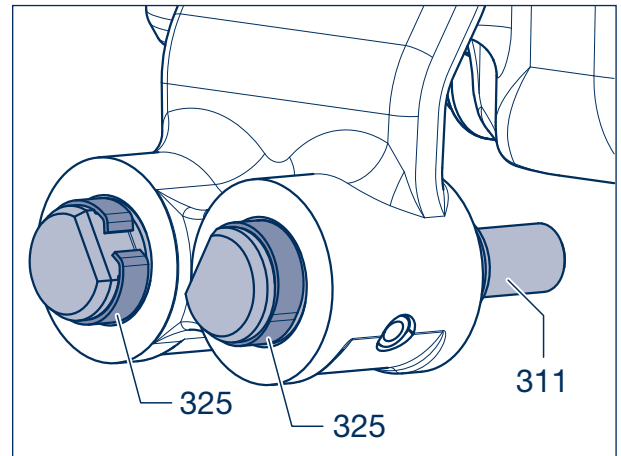

Picture 1

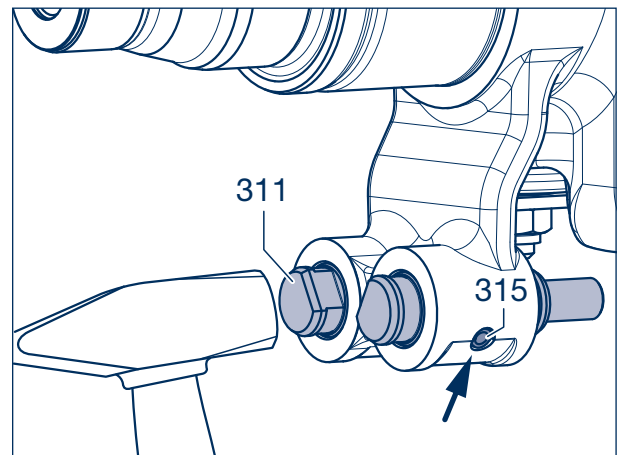

Picture 2

Installation

- [6] Insert a new brake bolt (311) into the brake anchor plate with the threaded hole pointing towards the axle beam.
-  Make sure the holes line up.
- [7] Drive the roll pin (315) into the brake anchor plate/brake bolt hole as far as the stop.
- [8] Mount new clasp locking rings (325) and grease the bearing points for the brake shoes (arrows) using BPW special longlife grease ECO-Li^{Plus}.

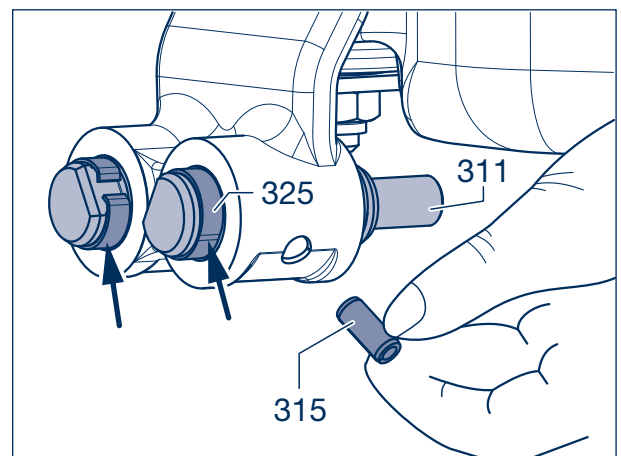

Picture 3

For brake shoes with closed eye**Removal**

- [1] Unscrew the hexagon nut (312, SW 30) from the brake pin (311).
- [2] Remove spring washer (314).
- [3] By means of a light tapping action with a hammer, extract the brake pins (311); apply counterpressure to brake anchor plate if necessary.

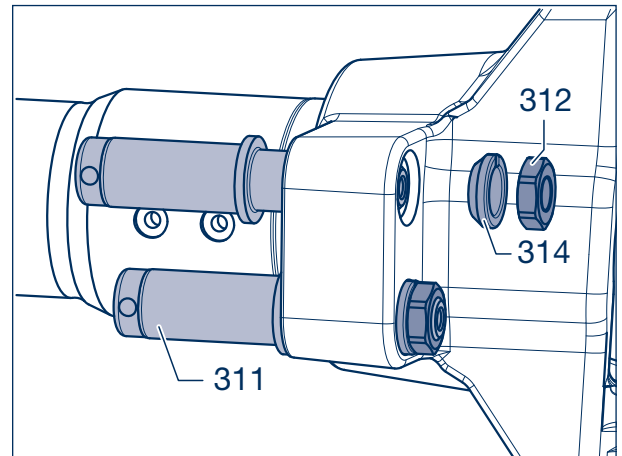
*Picture 4***Installation**

- [4] Clean the brake bolt seat (311) in the brake anchor plate.
- [5] Drive the brake bolt (311) in until it lies against the anchor plate.
- [6] Insert the tapered spring washer (314).
- [7] Screw on the hexagon nut (312, SW 30) and fasten with a torque of 200 N.

9 Steering axles with drum brakes

Brake plate

Removal

- [1] Remove the wheel/hub unit and brake shoes, see the workshop manuals for the corresponding rigid axles.
- [2] Remove the slack adjuster (280, 281) and the brake camshaft (240, 241) (see chapter 9.1 or 9.2 and 9.3).
- [3] Unscrew the locking screws (510, SW13) and remove the cover plates (501, 503).
- [4] Unscrew securing screws (288, SW 13 mm) from the brake mounting plate (285, 286) and pre-assemble the AGS reaction bracket (65) loosely.
- [5] Unscrew the hexagon bolts (67, SW24) with spring washers (199) and remove the brake mounting plate from the stub axle.
- [6] Clean the brake mounting plate to stub axle (40, 41) interface.

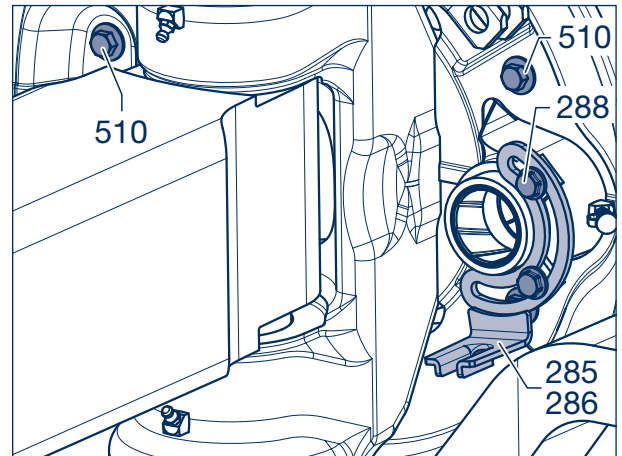

Picture 1

Assembly

- [7] Fix new brake plate (65) using hexagon bolts (67, SW 24) and spring washers (199).

Tightening torque:

M 16 x 1.5 M = 174 Nm

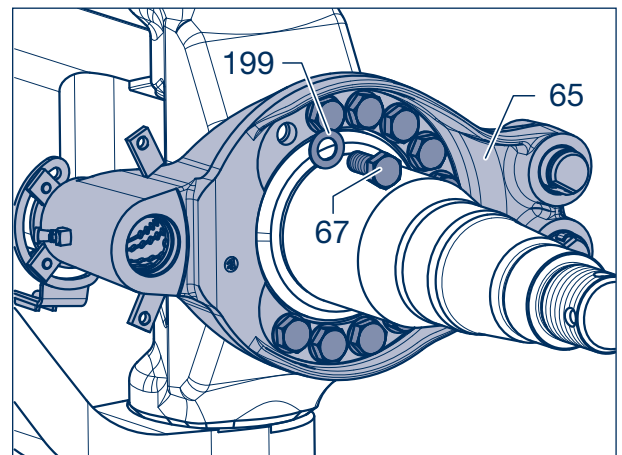

Picture 2

- [8] Screw in the new grease nipple (216) in the brake spider with a tightening torque of 15 Nm. Hereafter continue screwing until the head of the grease nipple has a position parallel to the brake S-camshaft heading in direction axle centre.
- [9] Put on protection cap (215).
- [10] Coat sockets (210, 211) in brake plate with BPW special longlife grease ECO-Li^{Plus}.
- [11] Fit brake camshaft (chapter 9.3) and brake bolt (chapter 9.5).

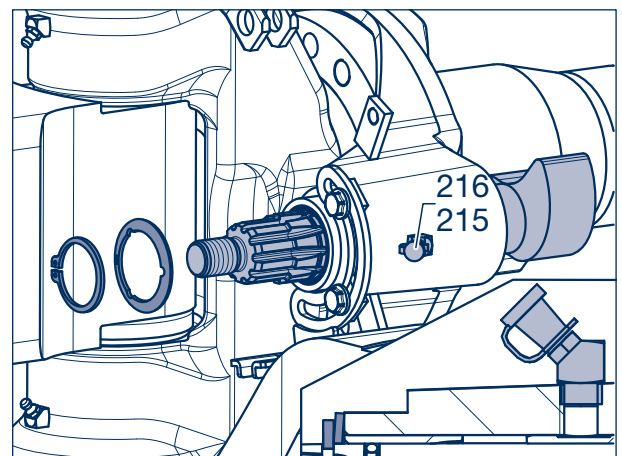

Picture 3

- [12] Fit cover plates (501, 503) and fit to the brake plate (65) or brake bolts (311) using the securing bolts (510, SW 13).

Tightening torque:

M 10 x 15 M = 43 Nm

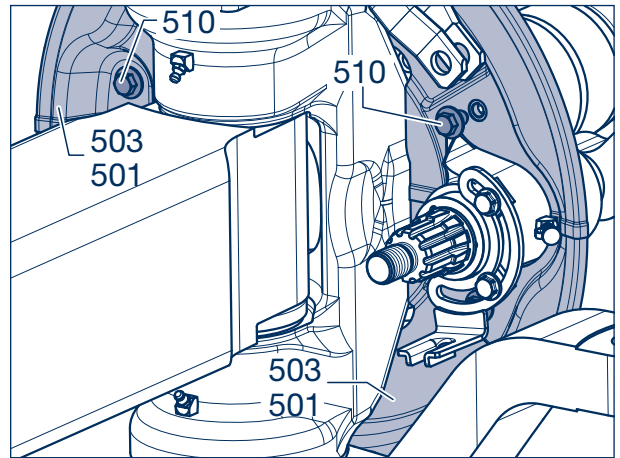

Picture 4

 **Only with ABS/ABV**

- [13] Mark position for the grooved pin (565, arrow) for securing the cable. Clearance approx. 80 mm from centre of brake bolt or in the line of the upper edge of the ABS block.
- [14] Make a drilling (arrow, Ø 4 mm / 12 mm deep) at the brake spider (65).
- [15] Attach the fixing clip (564) on the ABS cable and fix it with a grooved stud (565) on the brake spider.



Repair guide!
Do not damage the ABS cable!

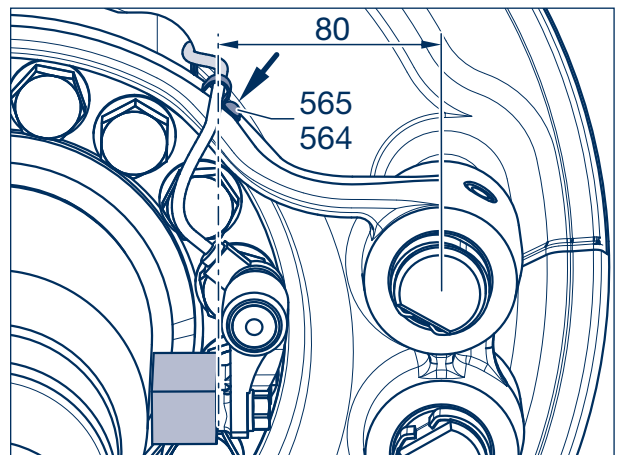

Picture 5

- [16] Fit slack adjuster, see chapter 9.1 or 9.2.
- [17] Fit wheel hub unit and brake shoes (see workshop manual of the relevant rigid axles).

10 Steering axle with disc brake

10.1 Screwing the brake caliper to steering axles with „ECO Disc” disc brake

- ☞ Disassembly / assembly of the brake linings and the brake caliper as well as the subsequent adjustment of the air gap; see also ECO Disc workshop manual.
- [1] Place brake caliper on brake anchor plate with fixed bearing (long guide pin) pointing downwards.

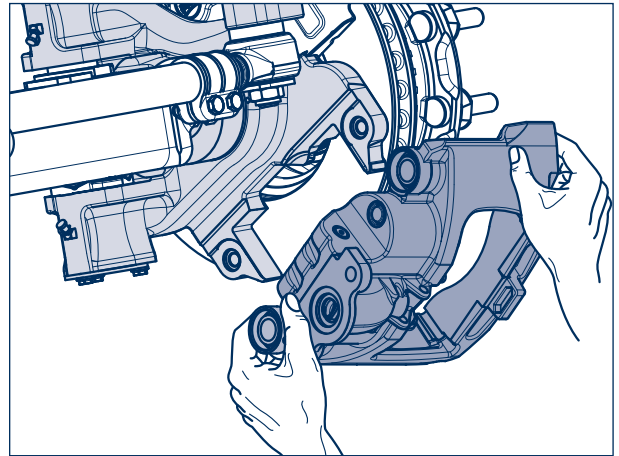

Picture 1



Repair guide!
Ensure that the bellows (354, picture 2) have sufficient space when the brake caliper is positioned to prevent any damage from occurring.



Repair guide!
Ensure that the bellows (354) and the ring (356) are seated properly on the guide pin when mounting the brake caliper.

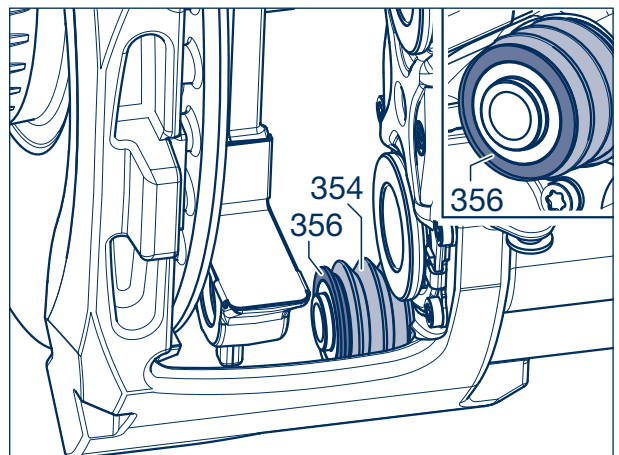

Picture 2

- [2] Apply BPW ECO Disc Grease to the new cylinder cap screws (325, 345 / SW 14) on the thread and the screw seating.

Cylinder cap screw (325)	M 16 x 1,5 x 100
Cylinder cap screw (345)	M 16 x 1,5 x 70

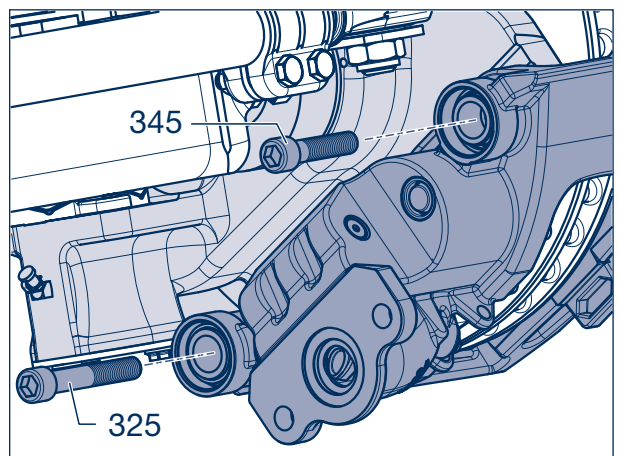

Picture 3

- [3] Screw in new cylinder head screws (325, 345) with an SW 14 adapter and tighten with
 M = **260 Nm** (250 - 270 Nm)
 or otherwise with
 150 Nm + 180° rotation angle.

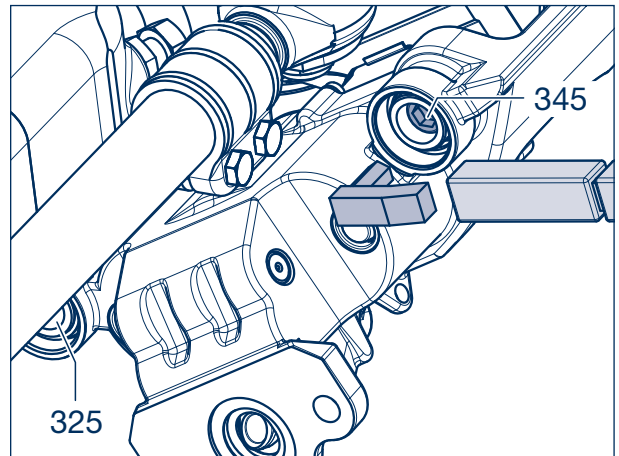

Picture 4

- [4] Screw in new sealing plugs for the caliper guide (335, SW 14) with O-rings (336).
 Tightening torque: **15 Nm** (15 - 20 Nm).
 [5] Check the brake caliper can be moved easily.

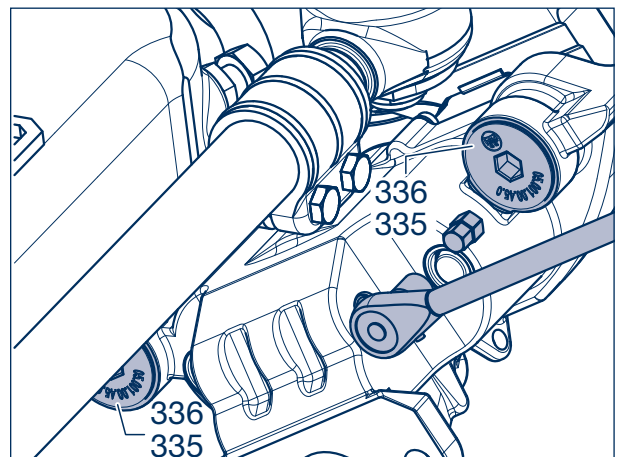

Picture 5

- [6] Fit brake pads.
 [7] Check adjustment (not required with replacement brake calipers) and re-calibrate (see workshop manual ECO Disc).

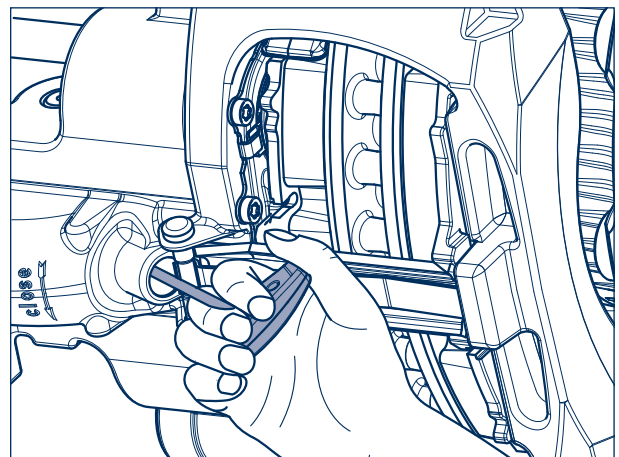

Picture 6

10 Steering axle with disc brake

10.2 Tangential screwed joint of the brake caliper SB 3745, SB 4309 and SB 4345

✎ Disassembly / assembly of the brake linings and the brake caliper as well as the subsequent adjustment of the air gap; see also workshop manuals for the respective rigid axles.



Repair guide!
The screws (313, 315) for fixing of the brake caliper mounting or the holder (300) are always mounted without grease.

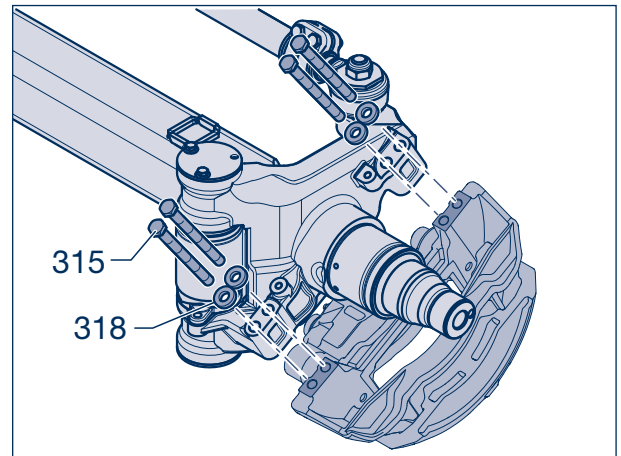

Picture 1

S hub (ET 0) (picture 1)

- [1] Clean installation surfaces for brake anchor plate / brake caliper mounting. These must be kept clean and free of paint or grease.
- [2] Pretighten one screw (315, SW 24) with washer (318) on the opposite side of the fixed bearing of the disc brake until the head touches the surface, then premount the remaining screws with washers.
- [3] Tighten screw (315) on the side of the fixed bearing up to the specified tightening torque of
M 16 x 1.5 M = **320 Nm** (300 - 350 Nm).
- [4] Tighten any screw on the opposite side to the specified tightening torque. Tighten the remaining screws.

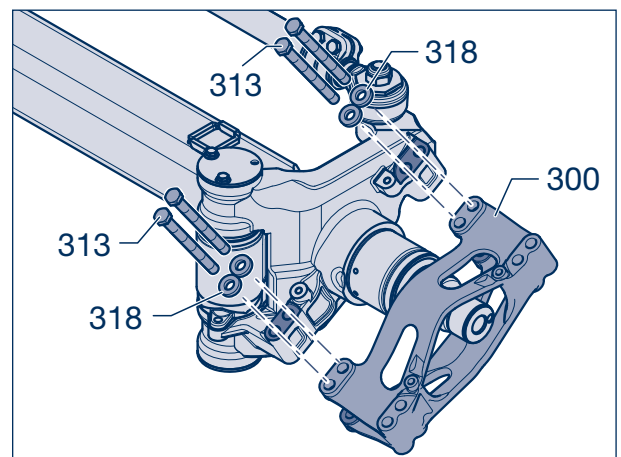

Picture 2

B hub (ET 120)

✎ For designs with B hub, a holder (300) must be mounted between the disc brake and the steering pivot assembly (picture 2).

- [1] Clean installation surfaces brake anchor plate / holder / brake caliper mounting (picture 2). These must be kept clean and free of paint or grease.
- [2] Use new cylinder head screws (313, SW 24) and washers (318) to screw the holder (300) in the correct position to the brake anchor plate and tighten all screws with **320 Nm** (300 - 350 Nm) (picture 2).
- [3] Use new screws (315, SW 24) and washers (318) to mount the brake caliper mounting to the holder (300).

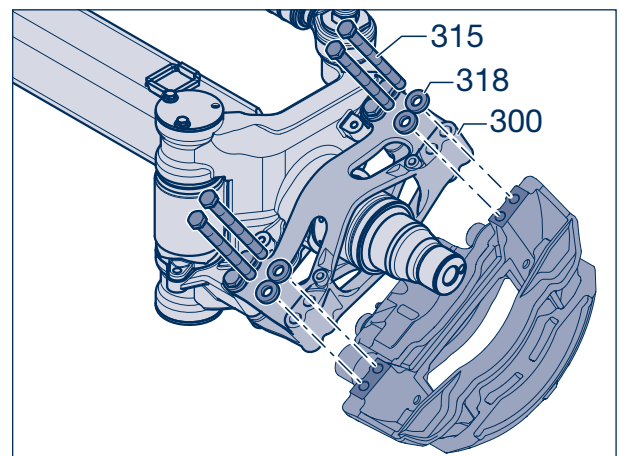

Picture 3

Tightening torque:

M 16 x 1.5 M = **320 Nm** (300 - 350 Nm)

10.3 Axial screwed joint of the brake cylinder SB 3745 and SB 4345

 Disassembly / assembly of the brake linings and the brake caliper as well as the subsequent adjustment of the air gap; see workshop manuals for the respective rigid axles.



Repair guide!

The screws (314, 315) for fixing of the brake caliper mounting or the holder (300, 301) are always mounted without grease.

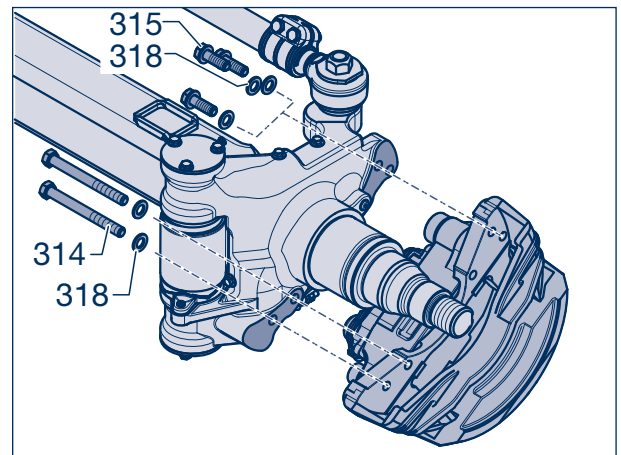

Picture 1

S hub (ET 0) (picture 1)

- [1] Clean installation surfaces for brake anchor plate / brake caliper mounting. These must be kept clean and free of paint or grease.
- [2] Use new screws (314, 315) and washers (128) to mount the brake caliper mounting to the brake anchor plate.

Tightening torque:

SB 3745 (SW 24):

M 16 x 1.5 M = **300 Nm** (280 - 330 Nm)

SB 4345 (SW 27):

M 18 x 1.5 M = **420 Nm** (400 - 460 Nm)

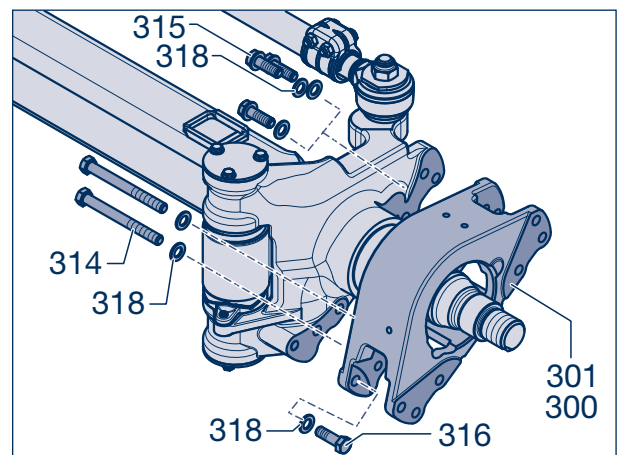

Picture 2

B hub (ET 120)

 For designs with B hub, a holder must be mounted between the disc brake and the steering pivot assembly (picture 2).

- [1] Clean installation surfaces brake anchor plate / holder / brake caliper mounting (picture 2). These must be kept clean and free of paint or grease.
- [2] Use a fitting screw (316) and a washer (318) to loosely fix the holder (300, 301) to the brake anchor plate (picture 2).
- [3] Use new cylinder head screws (314, 315 / SW 24) and washers (318) to screw the holder (300, 301) to the brake anchor plate and tighten all screws with **300 Nm** (280 330 Nm) (picture 2).
- [4] Use new screws (315, SW 24) and washers (318) to mount the brake caliper mounting to the holder (300, 301).

Tightening torque:

M 16 x 1.5 M = **300 Nm** (280 - 330 Nm)

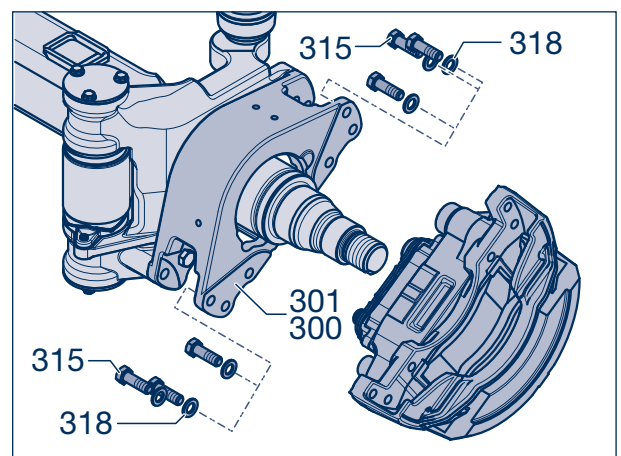

Picture 3

11 Track rod, LL Series

Removal

- [1] If fitted, remove the steering damper (605), see chapter 13.
- [2] In the case of suspended brake cylinders, remove the base plates (190, 191), see chapter 9.4.
- [3] Undo the clamping screws (163, SW 19) on the locking plate (160) of the steering lock.
- [4] Move the diaphragm cylinder of the steering lock (91) with compressed air and slide the locking plate (160) sideways out of the bracket (23).

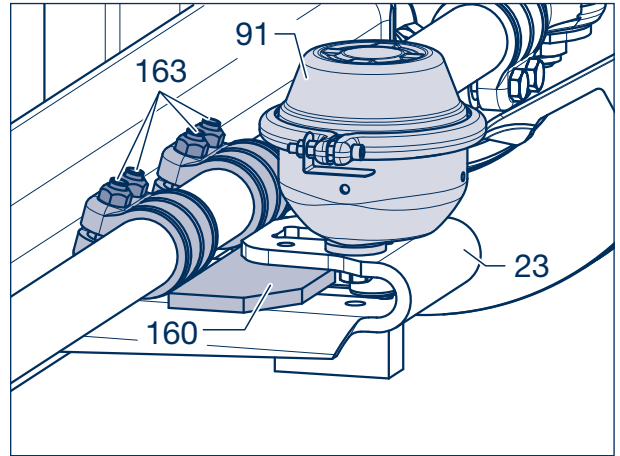

Picture 1

- [5] Unscrew the lock nuts (184, SW 36). Take off the washers (178).



Note:
Note the track rod head (152, 153) position in relation to the track rod (150).

- [6] Pull or press off the track rod (150).
- [7] If fitted, take the spacers (173, 175) off the threaded pins (171, 172).

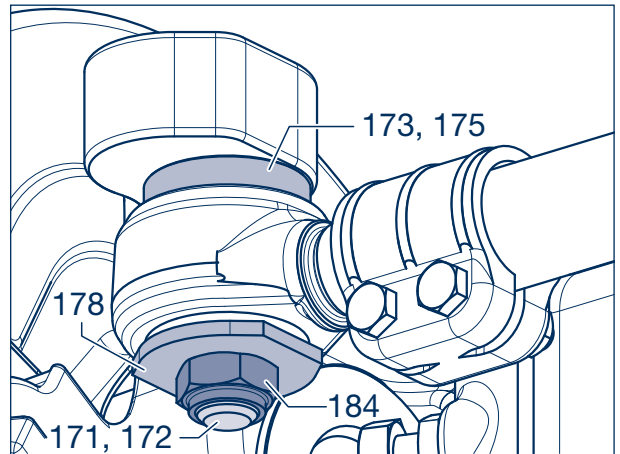

Picture 2

- [8] Check the steel-rubber-steel bushes (155) in the track rod heads (152, 153) and the threaded pins (171, 172) in the steering levers (40, 41) for wear and exchange them, if necessary.

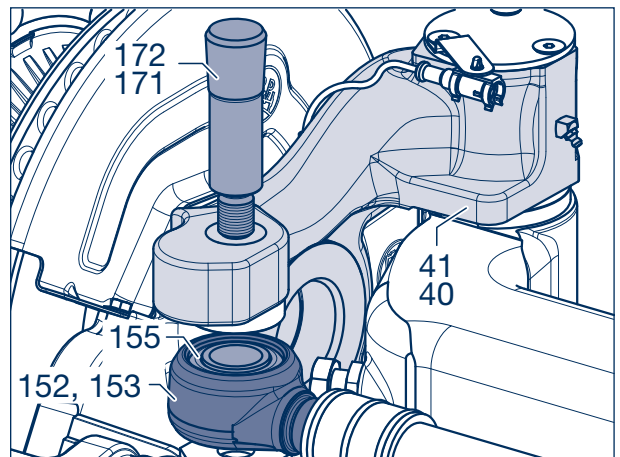

Picture 3

Installation

- [9] Slide the middle locking plate (160) on the track rod in the correct position. Fit the side clamps (162).
- [10] Screw the two track rod ends (152, 153) in equally. Note LH and RH thread.
- [11] First roughly adjust the track rod length to the threaded pin distance.

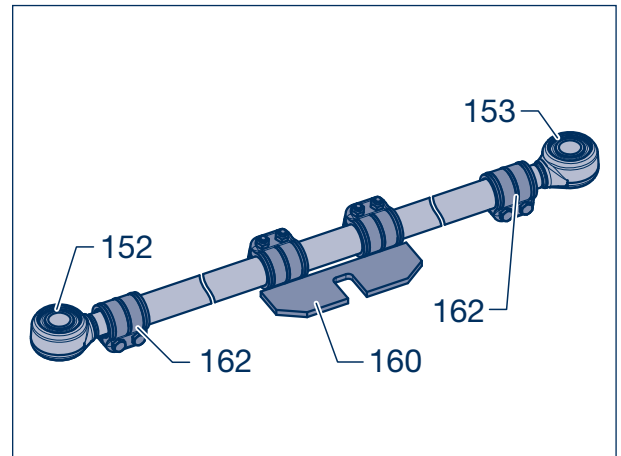

Picture 4



Repair guide!
When adjusting the track rod length, it is absolutely essential that the thrust washers (55, 56) are in zero position.

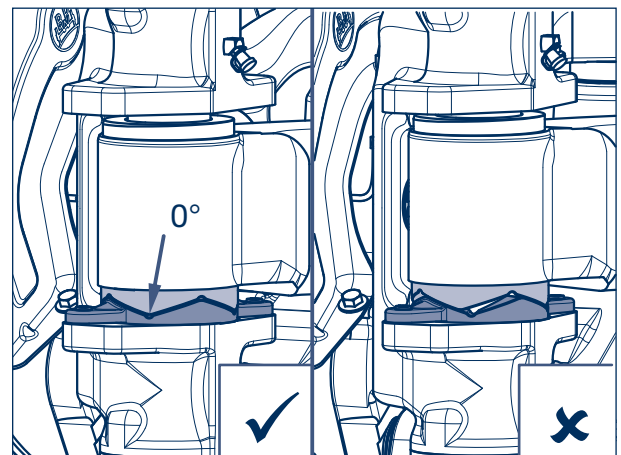

Picture 5

- [12] Mount one thread bolt (171, 172), if disassembled.
- [13] Depending upon the track rod length, fit shims (173, 175).

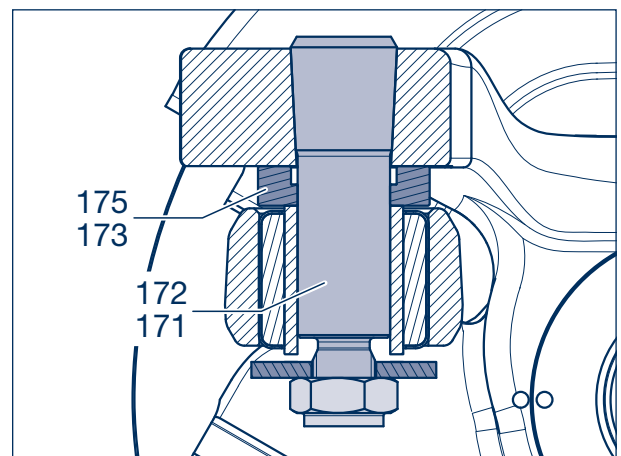

Picture 6

11 Track rod, LL Series

- [14] Slide the track rod in the correct position on one side onto the thread bolt (171) (ensure correct position of track rod heads). Align the other side **exactly** to the boring or the thread bolt in the steering lever by turning the track rod pipe.
- [15] In case it is disassembled, mount a second thread bolt.



Repair guide!

After exchange or alteration of the track rod, toe-in and tracking checks must be made: see chapter 15.

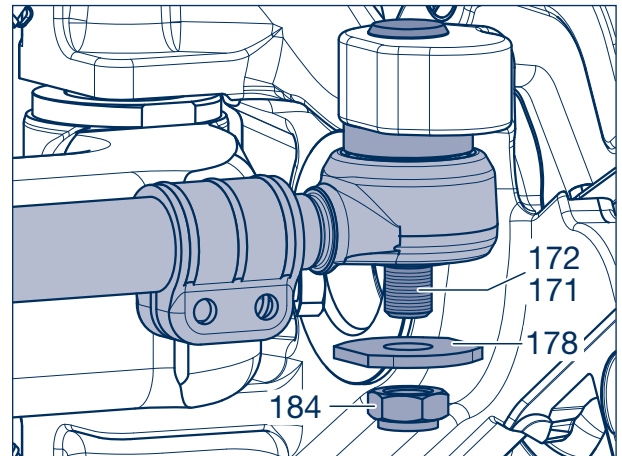

Picture 7

- [16] Fit the washers (178) and attach new lock nuts (184, SW 36), tightening them to the specified torque of
- 550 Nm for steering axles ≤ 12 t
 - 700 Nm for steering axles ≥ 14 t.



Note:

When fitting the nuts (184) hold the washer (178) with a pipe wrench or with an SW 65 engineer's wrench to stop it turning.

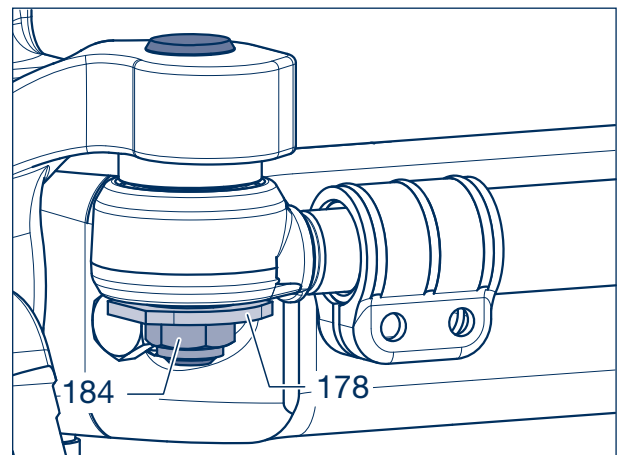

Picture 8

- [17] Check the outer clamps (162) for smooth movement. Tighten the lock nuts (164, SW 19) to the specified torque.

Tightening torques:

M 12	grade 8.8	M = 86 Nm
M 12 x 1.5	grade 8.8	M = 86 Nm

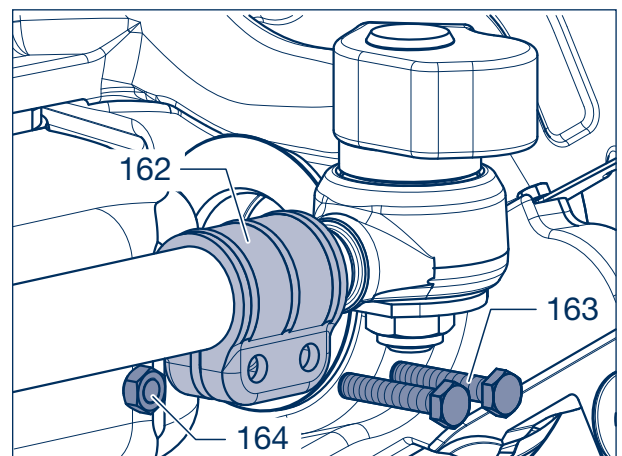

Picture 9

- [18] Move the diaphragm cylinder (91) of the steering lock with compressed air.
- [19] Slide the locking plate (160) to the middle of the track rod (150) and, with the thrust washer (55, 56) in the zero position, align it exactly with the locking block (96) of the diaphragm cylinder.
- [20] Vent the diaphragm cylinder (91).
- [21] Freely adjust the locking lever in the console (23) and to the movable locking block (96).

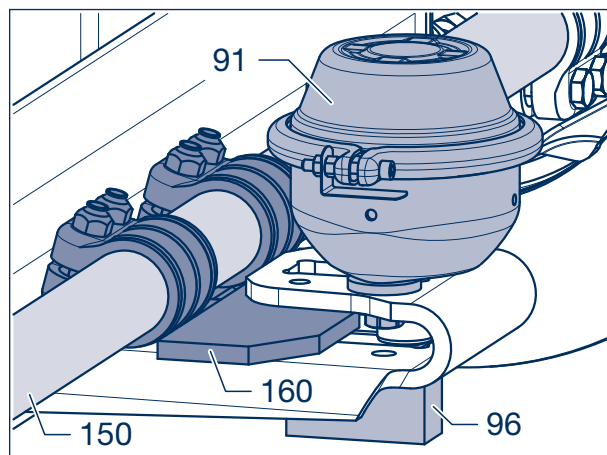

Picture 10

- [22] Tighten the locking nuts (164, SW 19) of the clamps to the specified torque of 86 Nm.
- [23] Re-fit any brake cylinder base plates that may have been removed, see chapter 9.4.

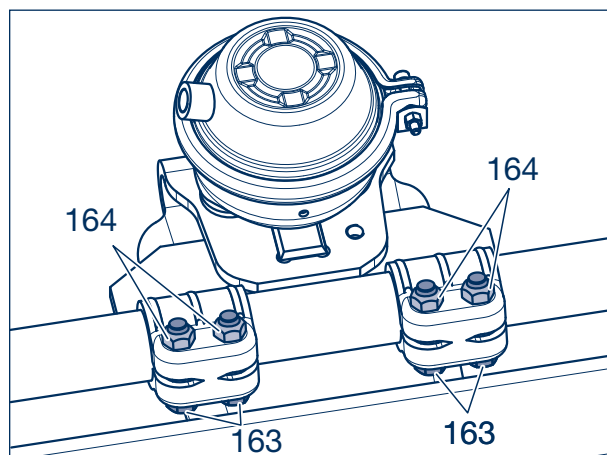

Picture 11

12 Steering lock, LL Series

Removal

- [1] Remove the compressed air hose from the diaphragm cylinder (91).
- [2] Unscrew the fixing nuts (99, SW 24) with spring washer (98) of the diaphragm cylinder. Take the diaphragm cylinder off the bracket (23).
- [3] For the removal of the locking block (96), heat the locking block to approx. 80° C to loosen the adhesive.
- [4] Move the diaphragm cylinder (91) with compressed air and unscrew the locking block.
- [5] To change the locking plate on the track rod (150), see chapter 11.

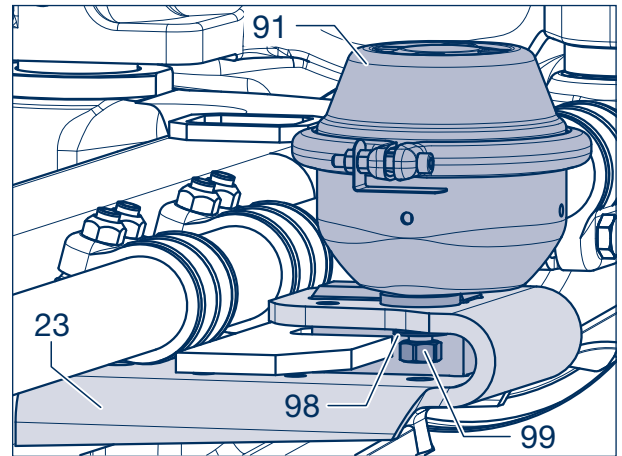

Picture 1

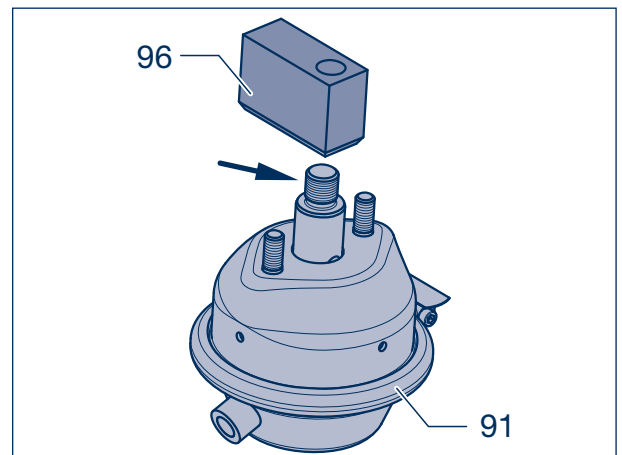

Picture 2

Installation

- [6] During the assembly of the movable locking block (96), coat the thread (picture 2, arrow) grease free with Loctite AVX and tighten it as far as it will go.
- [7] Install the diaphragm cylinder (91) with locking block (96) and shims (91/1) on the bracket. Fit the spring washers and M 12 x 1.5 hexagonal nuts (99, SW 24), tightening the nuts to the specified torque.
- [8] Fit the air connection.

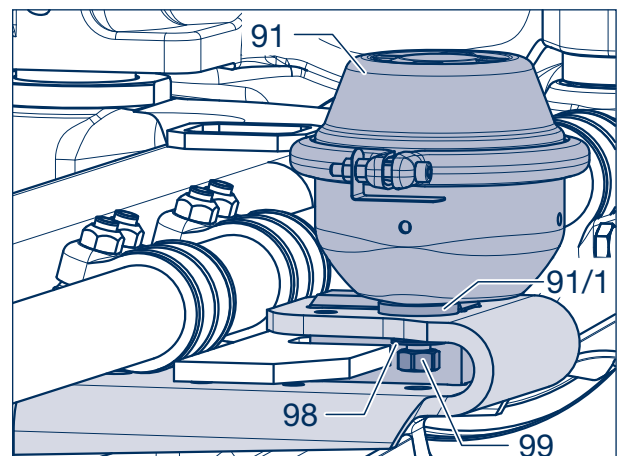

Picture 3



Warning:
The diaphragm cylinder is a special design with an extremely reinforced pressure spring! Defective cylinders may therefore only be replaced by new ones.

Plan of installations

i	Pressure ring	
k	O-ring	
l	Insertion sleeve	
200	Plastic pipe	8x1
301	GE-screw connection	M 12 x 1.5
303	GE-screw connection	M 16 x 1.5
304	GE-screw connection	M 22 x 1.5
361	W-screw connection	6 / 8
421	Double fitting with counter-nut	M 22 x 1.5

Function

In order to avoid uncontrolled turning of the steering pivot when a change of direction takes place, the self-steering axle is locked by a steering lock between the axle beam and the track rod connecting the steering pivots.

The steering lock is actuated by compressed air, and is usually controlled by the electronic brake system (EBS) or reversing light if reverse gear has been engaged.

On a secure surface, an engaged self-steering axle mostly passes through the zero position having reversed for a few metres, meaning that the lock can engage.

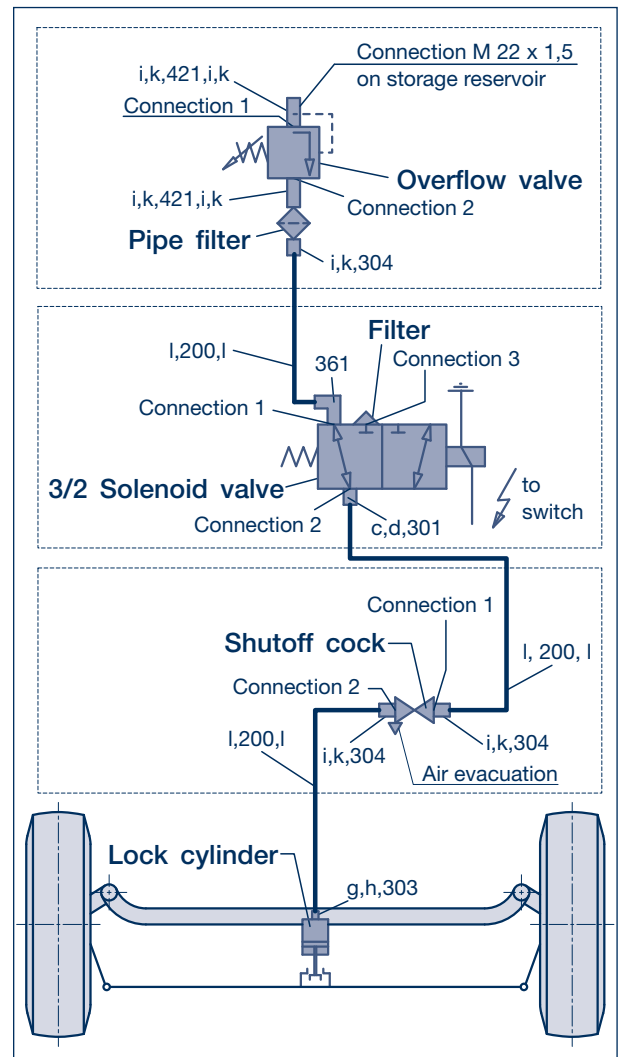

Picture 4

13 Steering damper, LL Series

13.1 Steering damper, Ø 32 mm

Removal

- [1] Unscrew the nuts (635, SW 17) of the hexagon screws (630, 632) and remove steering damper (605) with sleeve (654), if applicable.

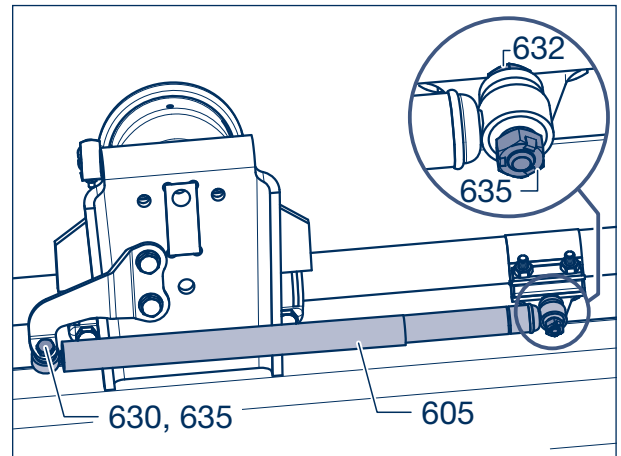

Picture 1

- [2] If required, take the moulded plate (625) and clamp (610) off the track rod (150). To do so, unscrew the nuts (620, SW 17).
- [3] Pull off the spring washers (618), moulded plate (625) and ring (615).

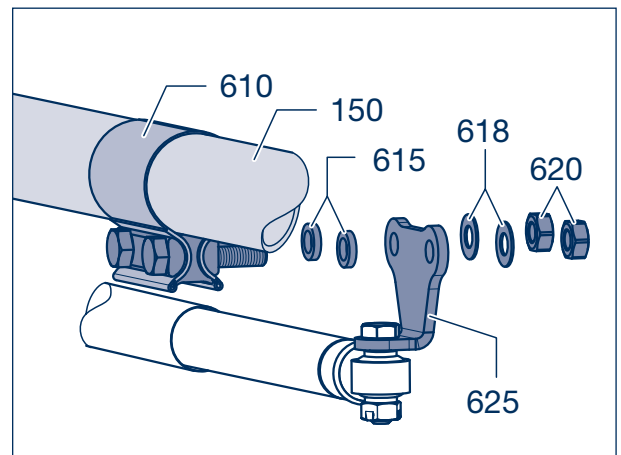

Picture 2

- [4] To remove the clamp (610), unscrew the hexagonal screws (614, SW 17) and take out the clamp with the segments (610/1-3).

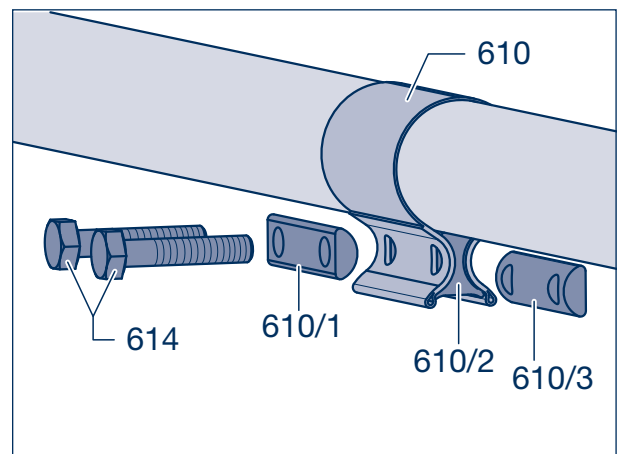

Picture 3

- [5] To disassemble the shaped plate (623), unscrew the two hexagon bolts (650, SW 19) with the spring washers (655).

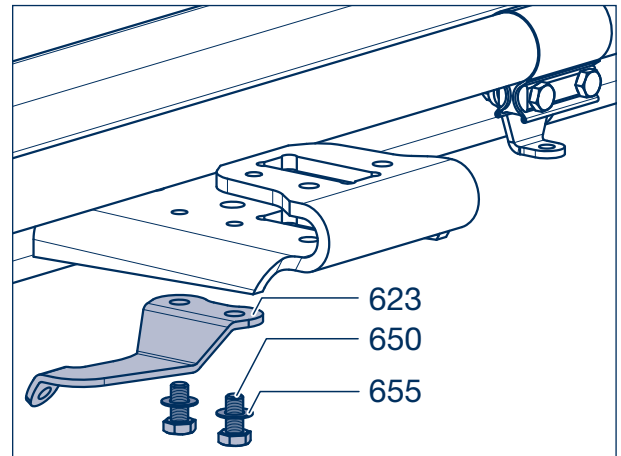

Picture 4

When fastening with a lock nut (660), unscrew it from the hexagon bolt (651, SW 19) and remove the shaped plate (623) with the sleeves (653), if applicable, spring washers (655) and hexagon bolt (650, SW 19).

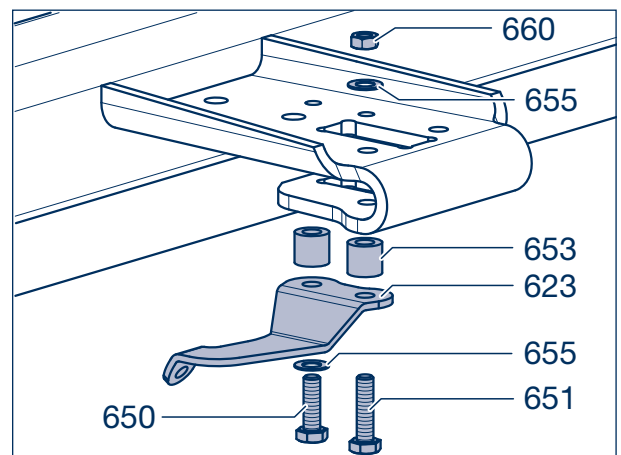

Picture 5

Installation



Repair guide!

If the springs are above the axle, the steering damper is fitted below the track rod (picture 6 left).

If the springs are below the axle, the steering damper is fitted above the track rod (picture 6 right).

For axles with disc brake, the steering damper is mounted beneath the track rod.

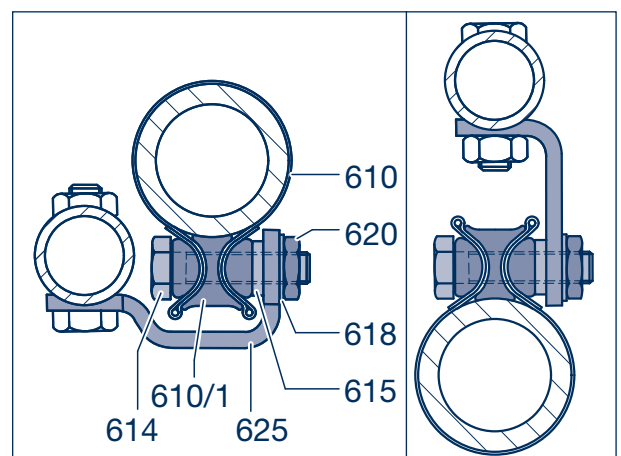

Picture 6

13 Steering damper, LL Series

- [6] Attach the shaped plate (623) onto the bracket of the steering lock (23) with two screws (650, SW 19) and spring washers (655).

Tightening torque:

M 12 M = 43 Nm

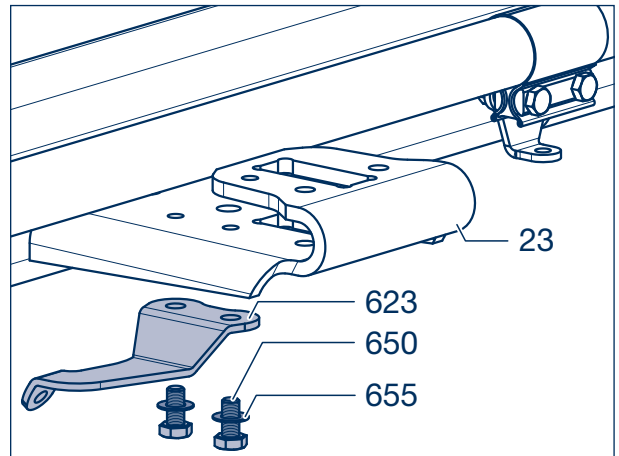

Picture 7

Attach the shaped plate (623) onto the bracket of the steering lock (23) with a lock nut (660) and hexagon head screw (651, SW 19), spring washer (655) and sleeve if applicable, and with a hexagon head screw (650, SW 19) and spring washer (655).

Tightening torque:

M 12 M = 43 Nm

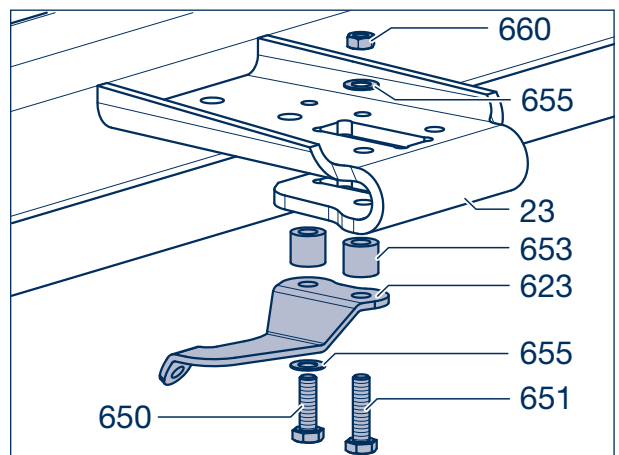

Picture 8

- [7] Adjust the clamp (610) to the dimension „L” of 472 mm at 12° steering turn or to 514 mm with 20° steering turn. Observe the zero position of the thrust washer (55, 56).

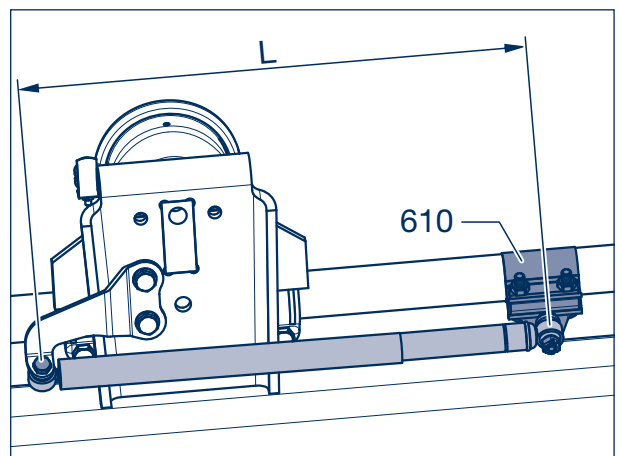

Picture 9

- [8] Attach the clamp (610) to the track rod with two hexagonal screws (614, SW 17). Fit the moulded plate with the narrow part (arrow) facing the track rod.

Tightening torque:

M 10 M = 74 Nm

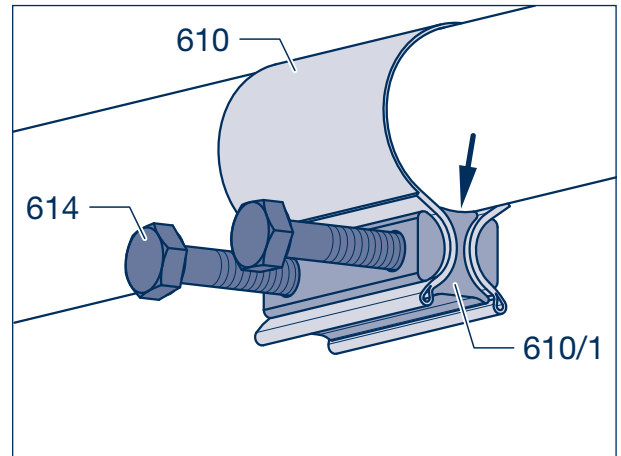

Picture 10

- [9] Install the rings (615) and moulded plate (625). Fit the spring washers (618) and hexagonal nuts (620, SW 17).

Tightening torque:

M 10 M = 26 Nm

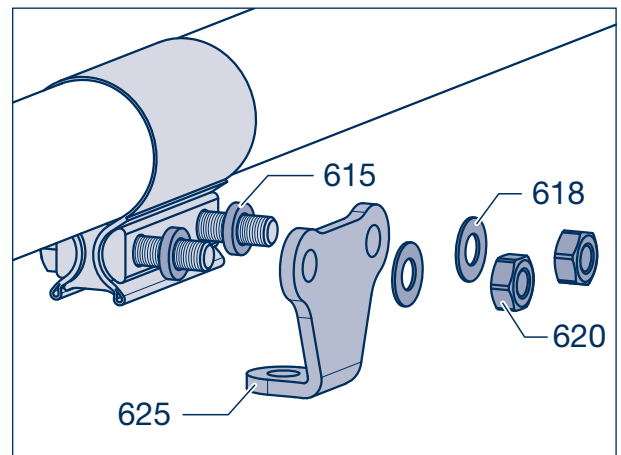

Picture 11

- [10] Use two hexagon bolts M 10 (630, 632) and lock nuts (635, SW 17) to screw on the steering damper (605).

Depending on the design, a distance sleeve (654) must be mounted between steering damper and shaped plate (623), see pages 8 and 9.

Tightening torque:

M 10 M = 26 Nm

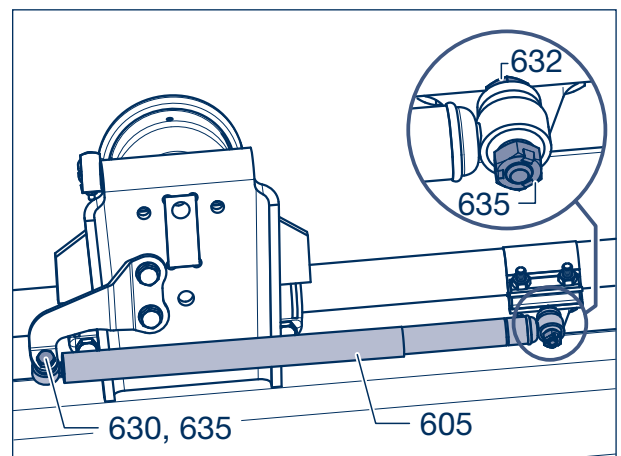

Picture 12

13 Steering damper, LL Series

13.2 Steering damper, Ø 82 mm

Removal

- [1] Unscrew the lock nuts (635, SW 36) and pull out the securing bolts (630, 632).
- [2] Remove the steering damper (605) and distance washers (631) (633, if applicable).



Note:
If the holder (625) has to be disassembled, first measure and note the length (L) between the securing bolts (630, 632). Pay attention here to the neutral position of the thrust washers (55, 56).

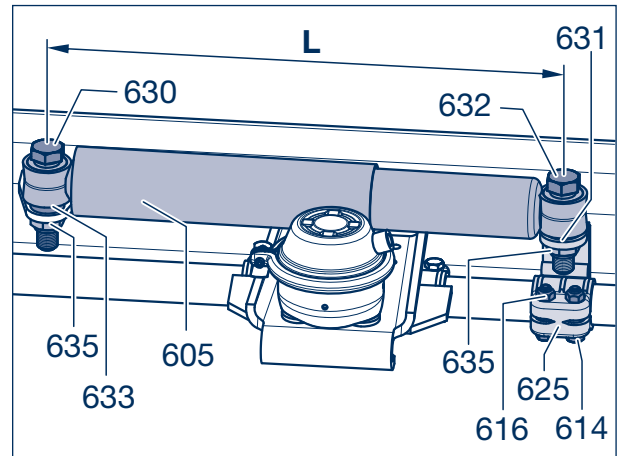

Picture 1

- [3] To remove the clamp (625), the track rod (150) must be taken out: see chapter 11.

Remove the track rod head (152, 153) and clamp (162) on the side in question. Slacken the fixing screws (614, SW 19) of the clamp (625) and pull the clamp off the track rod.

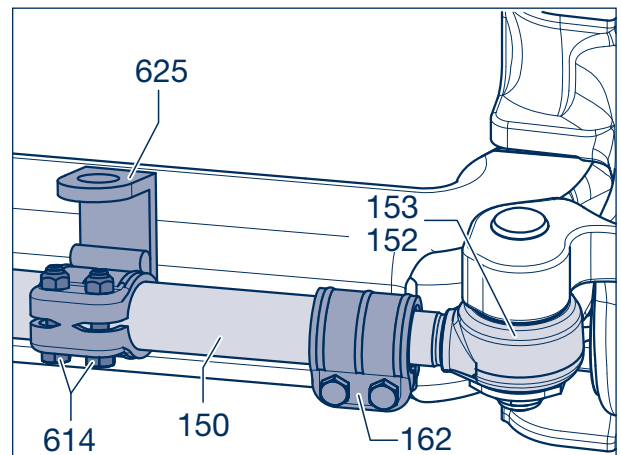

Picture 2

Installation

- [4] Slide the clamp (625) onto the track rod (150) in the correct position.
- [5] Fit the track rod, see chapter 11.
- [6] Adjust the holder (625) to the measurement measured during disassembly (L, 615 mm or 622 mm).

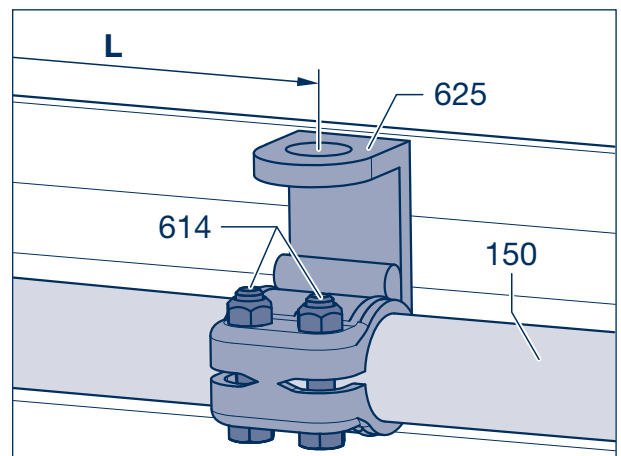

Picture 3

- [7] Mount the securing bolts (614, SW 19) with lock nuts (616) and tighten them with the specified tightening torque of 86 Nm.

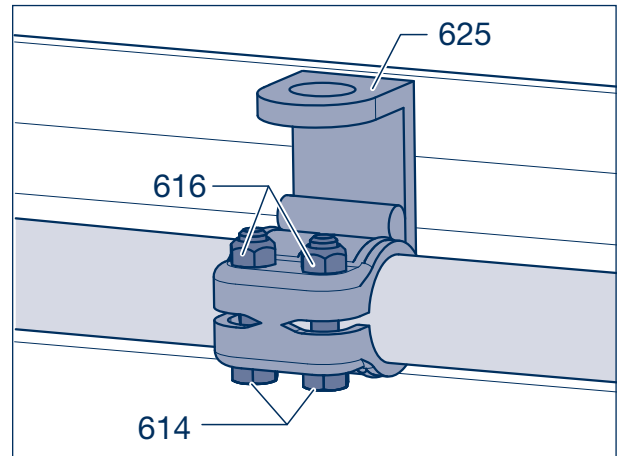

Picture 4



Repair guide!
Mount the steering damper (605) in such a fashion, that the notch (arrow) on the thinner part points down.

- [8] Use a hexagon bolt (632, SW 36) and lock nut (635) to screw on the thinner part of the steering damper and, if needed, mount a ring (631) between the steering damper and the holder (625).

Tightening torque:

M 24 M = 425 Nm

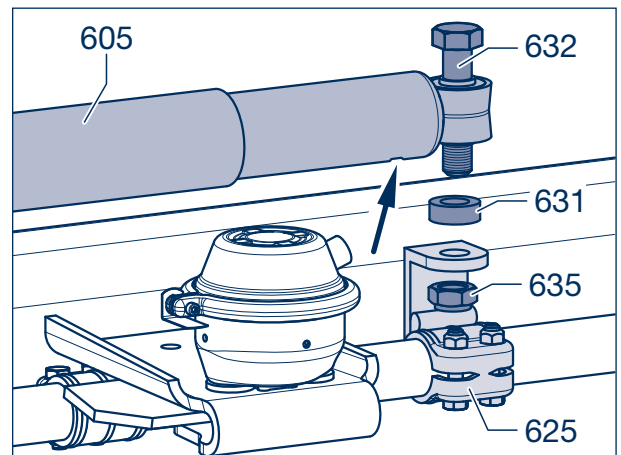

Picture 5

- [9] Screw the other side of the steering damper with shim (633) to the axle beam attachment plate.

- [10] Tighten the hexagon bolt (630, SW 36) with lock nut (635).

Tightening torque:

M 24 M = 425 Nm

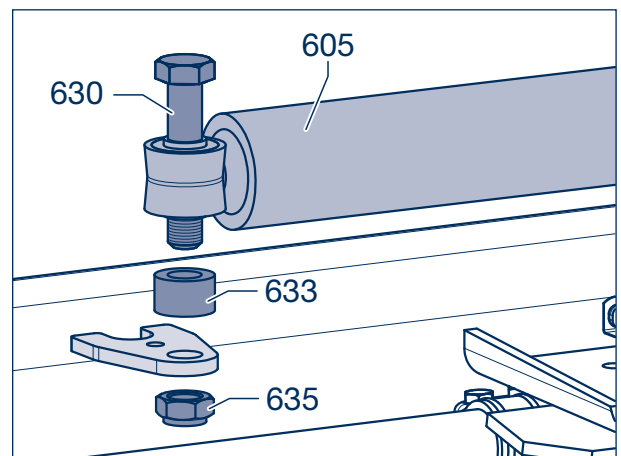

Picture 6

14 Steering pivot bearing

14.1 Steering pivot bearings, LL series



Repair guide!

Check the vertical play of the steering pivot bearing. If the vertical play is $X > 13$ mm, the shaft thrust washers (55, 56) are worn beyond the wear marking (arrow) or if the wear limit $H = 20$ mm is undercut, the shaft thrust washers must be replaced.

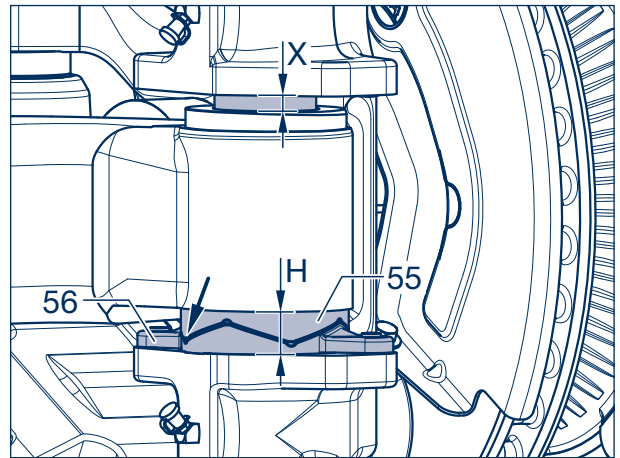

Picture 1

Removal

- [1] Remove the axle.
- [2] Take off the hubs and brake parts: see the manuals for the corresponding rigid axles.
- [3] Take off the track rod (150): see chapter 11.
- [4] Remove the base plates (190, 191) or the upper closing plates (77) and take out the compression springs (59).

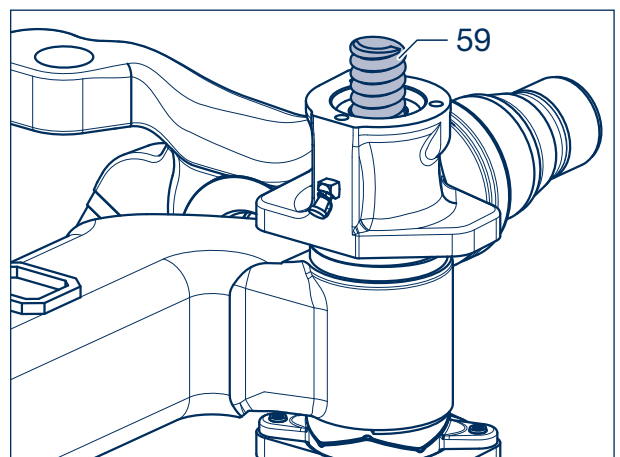

Picture 2

- [5] Turn the axle upside down so that the thrust washers (55, 56) are on top.
- [6] Unscrew the securing bolts (194) of the lower locking plates (77) or air cylinder brackets (190, 191) and take them off.

Inspect the steering pivot (52) and bushes (42) for wear. The wear limit of the bushes (42) is reached at a wall thickness of 1.8 mm; if necessary exchange components.

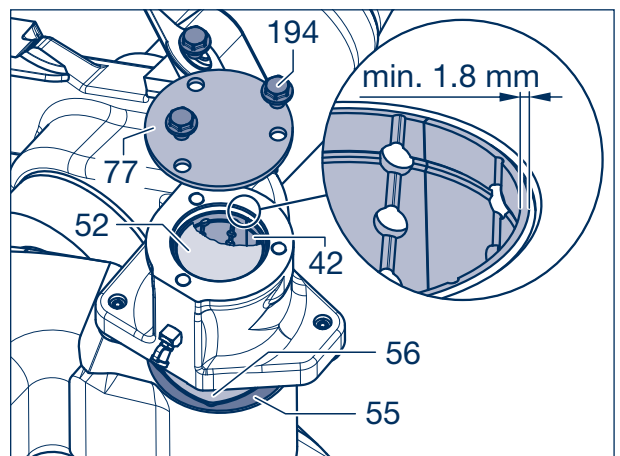

Picture 3

- [7] Drive the two front roll pins (60, 61) out of the mountings in the steering swivel (40, 41).
- [8] Drive the two rear roll pins (60, 61) as far as possible out of the axle beam (10).

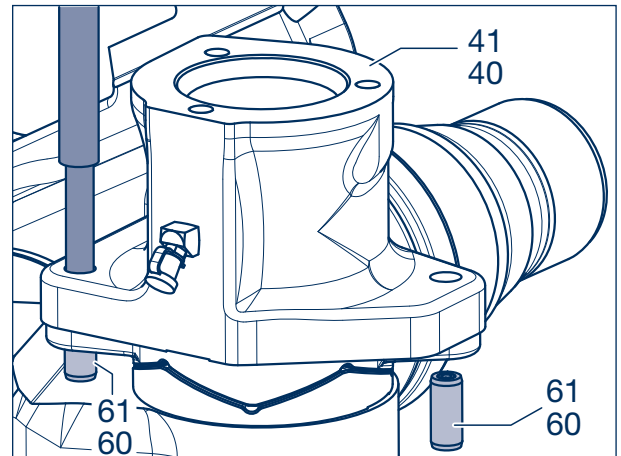

Picture 4

- [9] Place the steering swivel (40, 41) under a press so that the thrust washers (55, 56) are below and the steering swivel is upright (the thrust washers rest against each other).
- [10] Exert slight pressure on the steering pivot (52) with a suitable mandrel.
- [11] Heat the stub axle on the end face with a large weld torch flame until the steering pivot (52) is loosened, then force it right out in one go with the press.

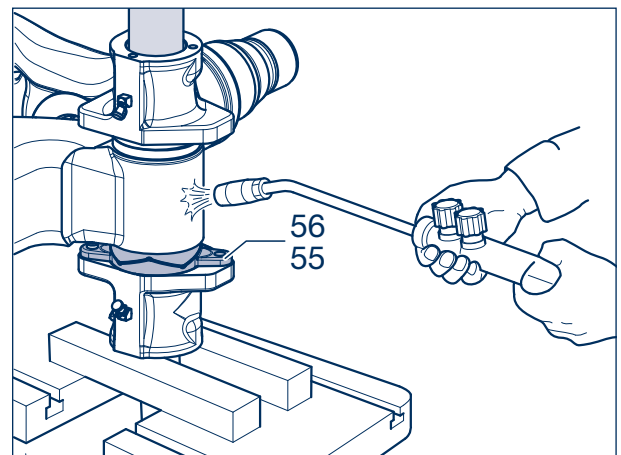

Picture 5

**Repair guide!**

If the steering pivot is pressed out without being heated, the steering swivel bore will be destroyed.

**Repair guide!**

Mark the steering swivel (40, 41) and thrust washers (55, 56) so that they can be refitted in the same position later.

- [12] Remove the steering swivel (40, 41) and thrust washer (56).

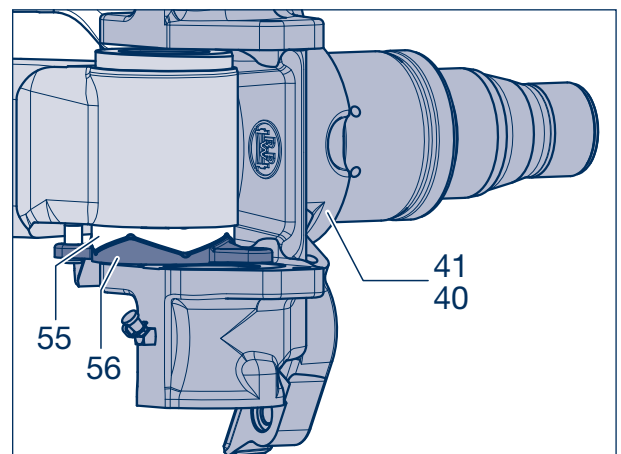

Picture 6

**Repair guide!**

Depending on design, it may become necessary to loosen the welding seams on the thrust washers (55, 56) in order to take off the steering pivot assembly (40, 41).

14 Steering pivot bearing

- [13] Inspect the steering pivot (52) and bushes (42) for wear. Make a visual inspection by opening up the upper and lower bearings - the wear limit of the bushes is reached at a wall thickness of 1.8 mm. If necessary, exchange components.

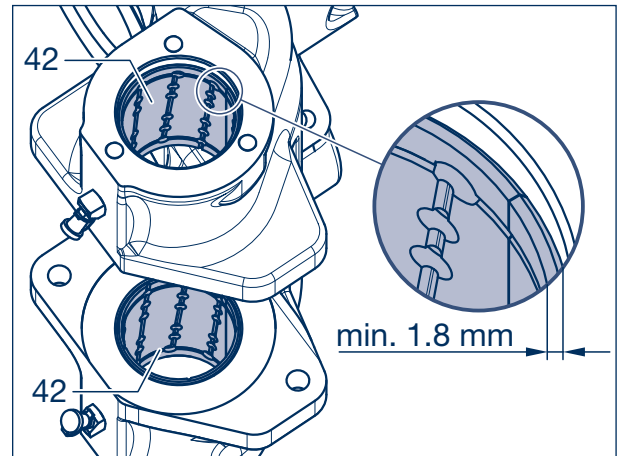

Picture 7

- [14] Inspect the thrust washers (55, 56) for wear and if necessary exchange them.



Note:
New thrust washers together have a total height H of 25 mm. Wear is approx. 1 mm or after 500,000 km.

Admissible wear limit
H = 20 mm

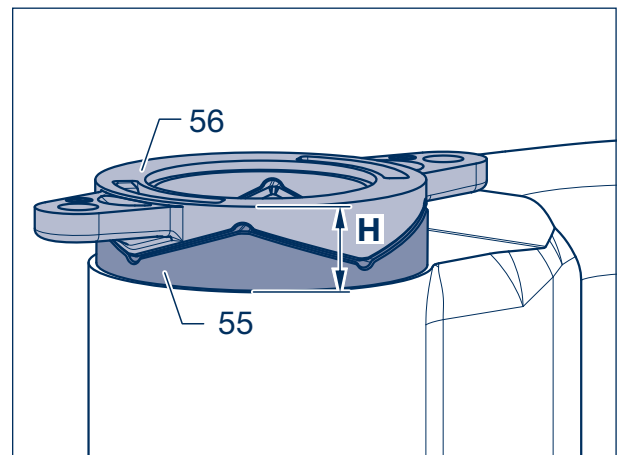

Picture 8



Note:
Depending on the design of the thrust washer (55), there may be a ribbing on the outside as a wear marker. If this marker is no longer visible, the thrust washers (55, 56) must be replaced.

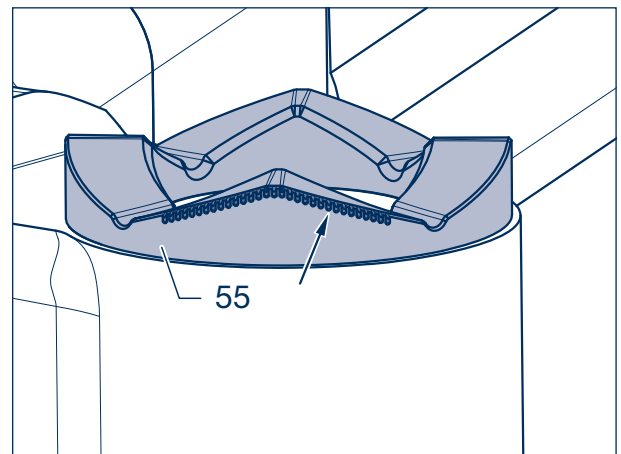

Picture 9

- [15] To exchange the thrust washers (55), grind down the weld seams (arrow) on the stub axle. Using a chisel, lift the pinned thrust washer off the axle beam. Do not damage the mating surface on the axle beam.



Repair guide!

Thrust washers (55, 56) must always be exchanged in pairs at the top and bottom and on both sides.

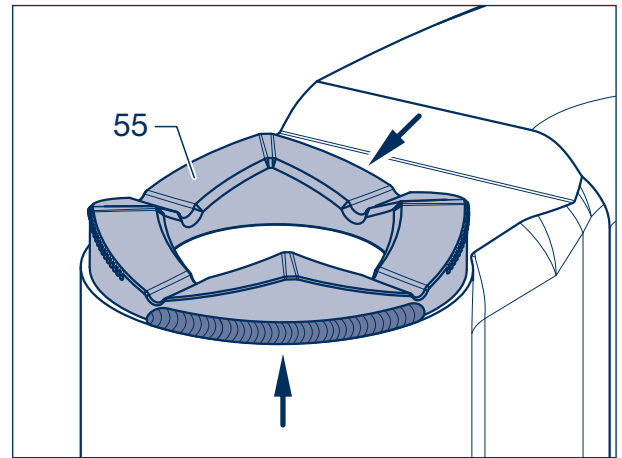

Picture 10

Installation

4-part thrust washer

(3-part thrust washer: see from work step [22] onwards)

Steering axle starting with calendar week 19/1997:

- [16] Drive two new, thick adapter sleeves (64, Ø 12 x 12) into the thrust washer (55) in such a fashion that the slots point towards the rotating direction, as shown in the illustration (arrows). Then drive two thin adapter sleeves (63, Ø 7 x 18) into the thick adapter sleeves in such a fashion that the slots face each other.

Steering axle up to calendar week 18/1997:

- [16] Drive two new, thick adapter sleeves (63, Ø 12 x 16) into the thrust washer (55) in such fashion, that the slots are positioned as shown in the illustration (arrows).

- [17] Place the thrust washer (55) onto the axle stub. The installation surfaces must be clean, free of grease and level.

- [18] Insert adapter sleeves (63, 64) into the borings.

- [19] Drive the thrust washer onto its seat with a plastic hammer.

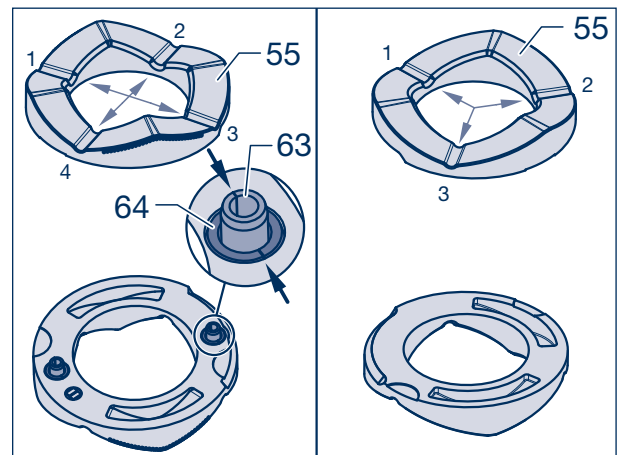

Picture 11

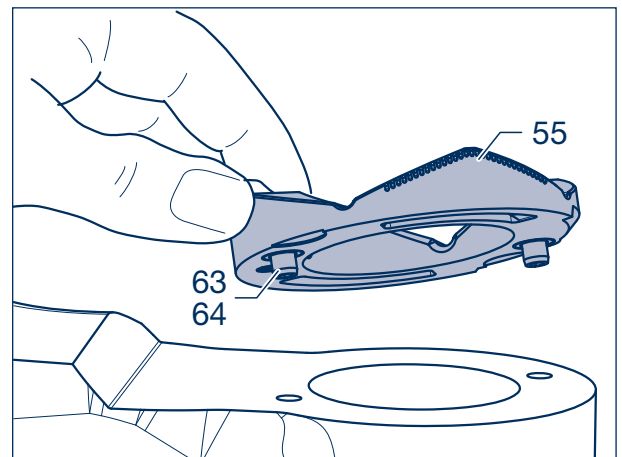

Picture 12

14 Steering pivot bearing

- [20] Tension the thrust washers (55) with the stub axle and weld them into position with a single pass, as shown in the drawing.

Rod electrode DIN EN 1600: E 18 8 Mn B 22
or alternatively
cored-wire electrode ISO 17633-A T 18 8 Mn M M 2
solid-wire electrode ISO 14343-A G 18 8 Mn

Weld seam thickness: a 3.5 Δ (DIN 1912)

- [21] Remove the weld spatter.

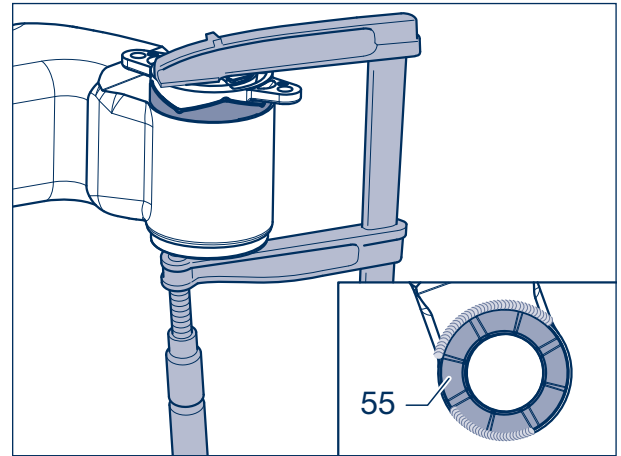

Picture 13

- [22] Press new bushes (42) for the steering pivot (52) in with a suitable mandrel carefully and without tilting them until they make full contact with the inner mating surfaces (arrow) of the steering pivot (40, 41).

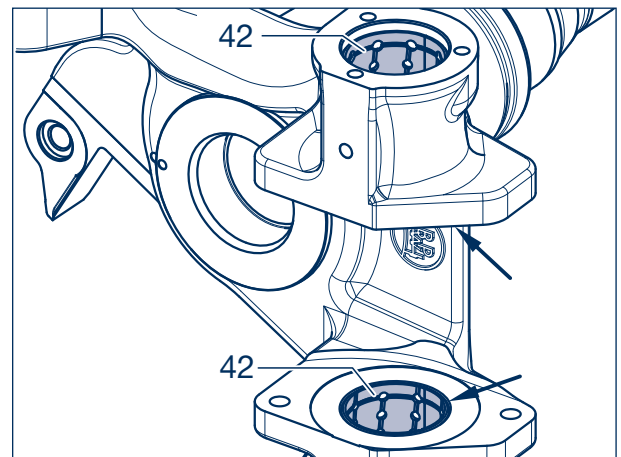

Picture 14



Repair guide!
The inner open lubrication passages (1) must face towards the middle of the axle.

- [23] Check whether the steering pivot (52) slides smoothly into the bushes (42); if necessary re-work the bushes.

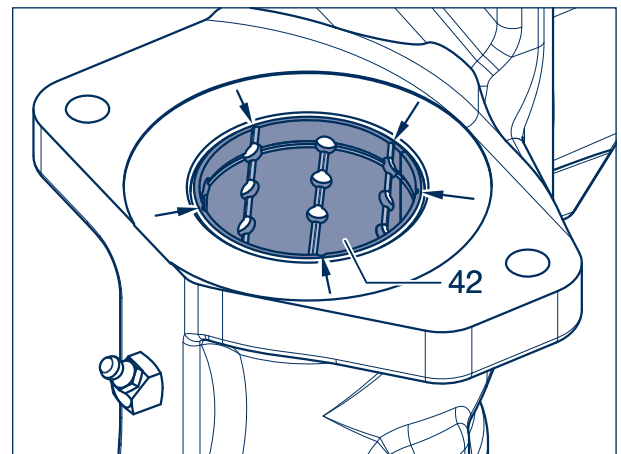

Picture 15

- [24] Since the axle is fitted upside down a 55 x 9 mm dia. spacer should be placed **in the upper steering pivot bearing** to assist installation. Attach the upper closing plate (77) or base plate (190, 191) (without the compression spring (59)) with two screws (194).

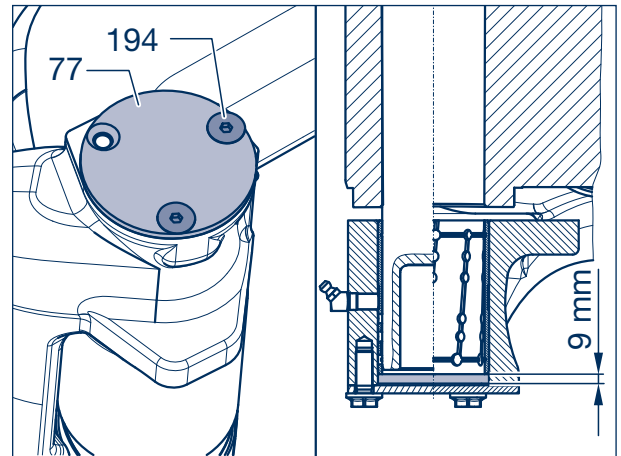

Picture 16

- [25] Set up the axle beam in such a way that the thrust washers (55) are **on top**.

3-part thrust washer

- [26] Loosely place the thrust washer (55) on the axle stub. Here both notches in the bearing surface must point towards the axle stub. The welding chamfer points to the axle beam.

The thrust washers are welded after tracking, see chapter 15.1.

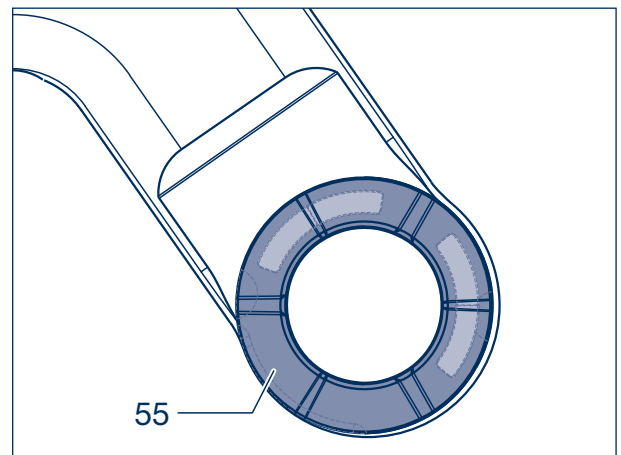

Picture 17

3-part and 4-part thrust washers

- [27] Insert the seal (57) into the thrust washer (56) in the correct position.

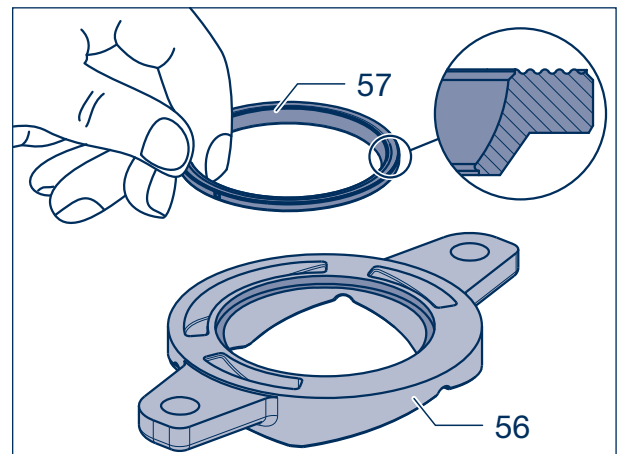

Picture 18

14 Steering pivot bearing

[28] Place the thrust washer (56) in position.



Repair guide!

In case of 3-part thrust washers and older model thrust washers, the center indentation (arrow) must point towards the steering pivot assembly.

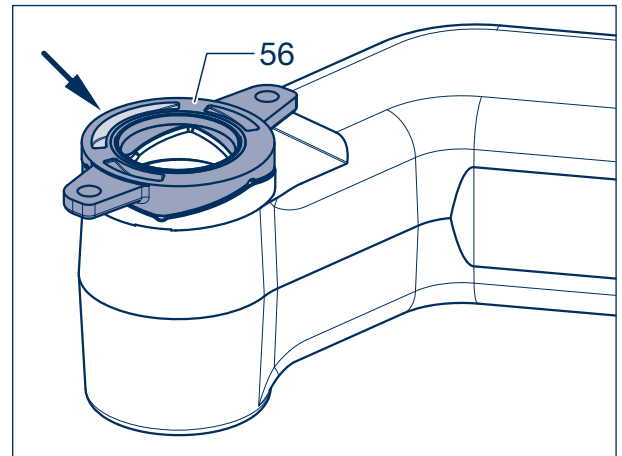

Picture 19

[29] Place the steering swivel (40, 41) on the thrust washer (56) (spacer washer from work step [24] underneath).

[30] Use a guiding spike (approx. 0.1 mm thinner than the steering pivot) to align all borings for the steering pivot (52).



Repair guide!

After withdrawing the guide mandrel, do not move the steering swivel (40, 41) any more.

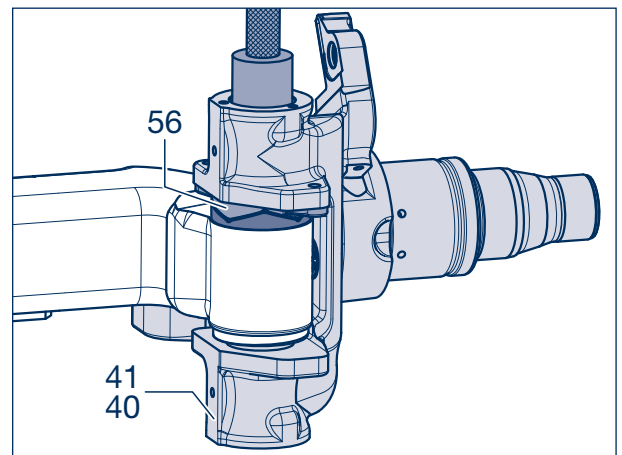

Picture 20

[31] Heat axle stub in the lower to medium area on both sides until a circular dark red coloration is visible. Do not overheat the thrust washer (56) in order not to damage the interior seal (57).



Note:

To ease installation, the steering pivot can also be cooled down to approx. -30° C.

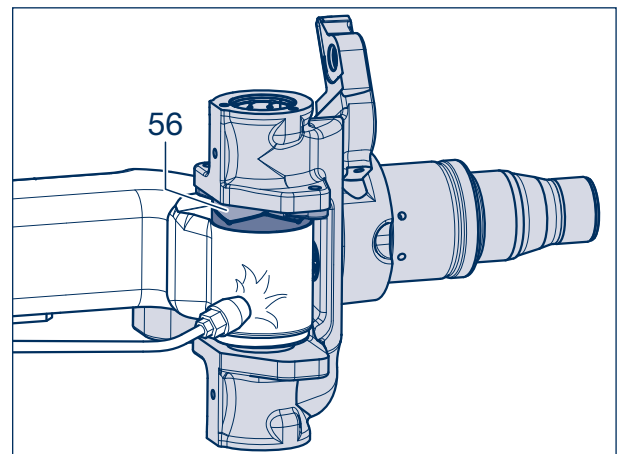

Picture 21

- [32] Press the steering pivot (52) into position in one go with the bore for the compression spring (59) facing downwards; if necessary drive it in with gentle taps of a hammer.
- [33] Remove the closing plate (77) or base plate (190, 191) and take out the spacer.

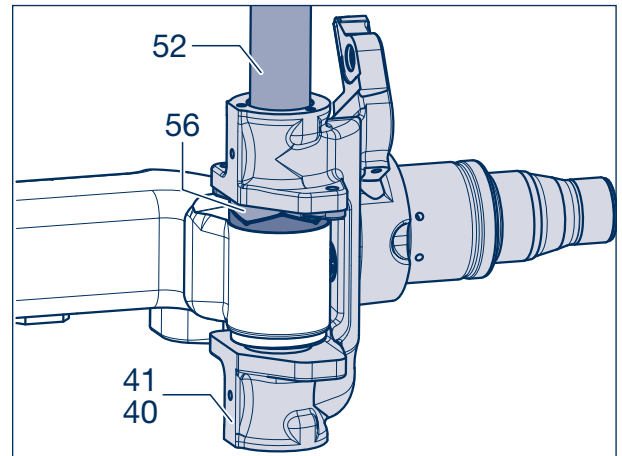

Picture 22

- [34] Drive thick roll pins (60) into the mountings in the steering swivel (40, 41) and the thrust washer (56) in such a way that the slots (arrow) are always in the direction of rotation of the steering swivel.

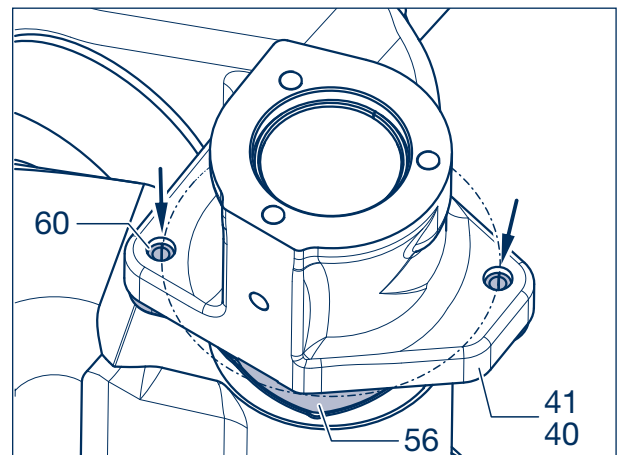

Picture 23

- [35] Then drive the thin roll pins (61) into the thick roll pins (60) in such a way that the slots are opposite.

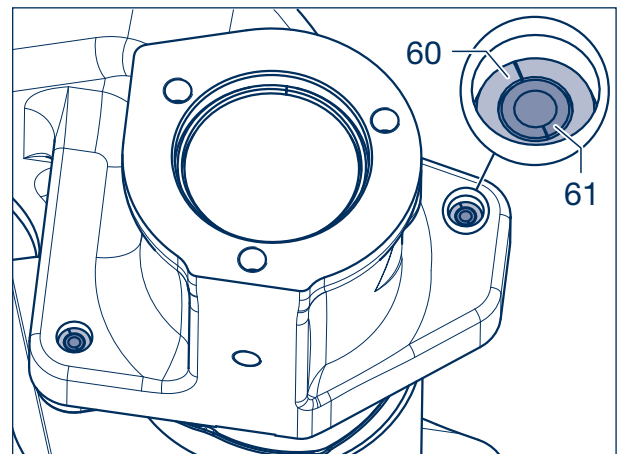

Picture 24

14 Steering pivot bearing

- [36] Continue to drive both roll pins (60, 61) until they project a little at the bottom of the thrust washer (56, arrow).
- [37] Then drive them back until the thrust washer (56) rests against the steering swivel (40, 41) and the roll pins (60, 61) still project approx. 1 mm. Position the roll pins in the bores of the steering swivel with two blows of a centrepunch.

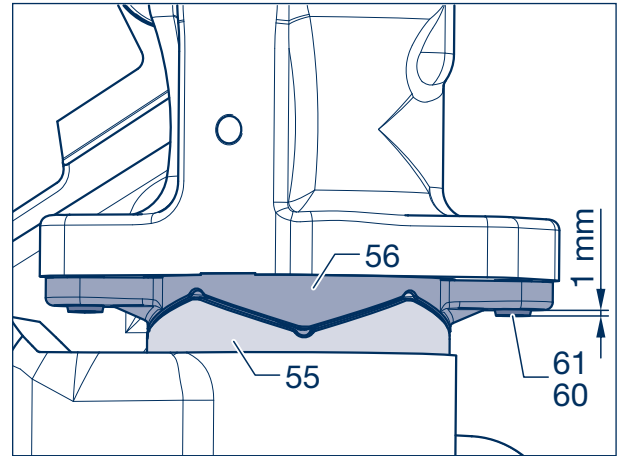

Picture 25

- [38] Close the lower king pin assembly. Depending on design, mount lower locking plates (77) or air cylinder brackets (190, 191) with safety screws or hexagon bolts (194, 195) and spring washers (199) and tighten with the specified tightening torque.

Hexagon, safety and countersunk screws

M 10 - 10.9 / SW 15	M = 53 Nm
M 14 - 10.9 / SW 19	M = 148 Nm
M 16 - 10.9 / SW 24	M = 230 Nm

Cylinder, hexagon and countersunk screws

M 16 - 8.8 / SW 12	M = 163 Nm
--------------------	------------

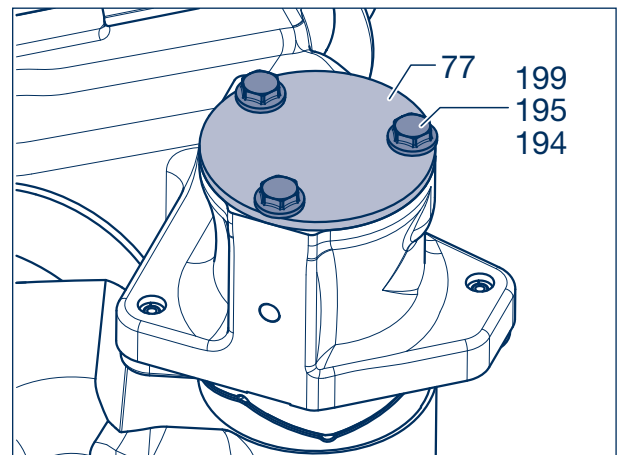

Picture 26

- [39] Coat upper and lower contact surface of pressure spring with grease.
- [40] Place the compression spring (59) in the bore of the steering pivot (52). Fit the base plate (190, 191) or upper closing plate (77) with locking screws or hexagonal screws (194, 195) and spring washers (199). If needed, use longer screws for preloading.
- [41] Tighten the screws crosswise until the compression spring (59) is tensioned. Tightening torques:

Hexagon, safety and countersunk screws

M 10 - 10.9 / SW 15	M = 53 Nm
M 14 - 10.9 / SW 19	M = 148 Nm
M 16 - 10.9 / SW 24	M = 230 Nm

Cylinder, hexagon and countersunk screws

M 16 - 8.8 / SW 12	M = 163 Nm
--------------------	------------

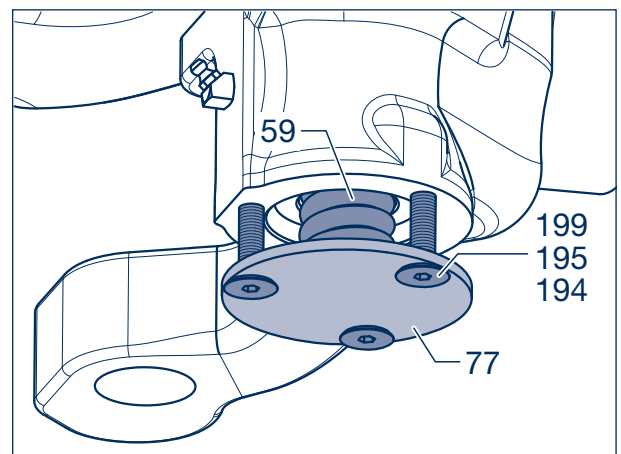

Picture 27

- [42] Rotate axle back to installation position.
- [43] Weld thrust washer (56) to the steering pivot assembly (40, 41) in one layer according to the drawing.

Rod electrode DIN EN 1600: E 18 8 Mn B 22
 or alternatively
 cored-wire electrode ISO 17633-A T 18 8 Mn M M 2
 solid-wire electrode ISO 14343-A G 18 8 Mn

Weld seam thickness: a 3.5 Δ (DIN 1912)

- [44] Remove the weld spatter.

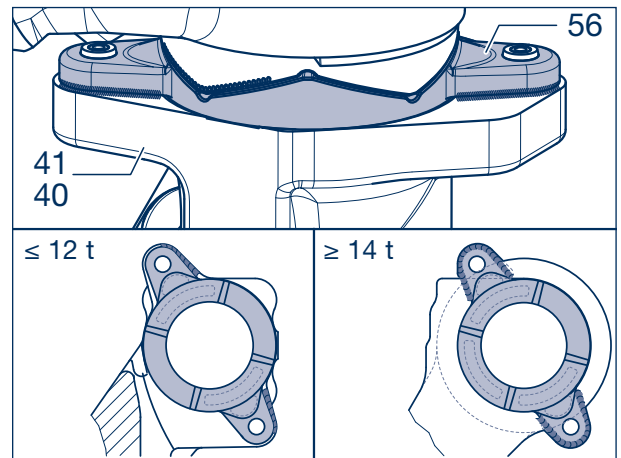

Picture 28

-  Fit the track rod (150) and steering lock: see chapter 11 and 12.

-  Fit the brakes and hubs.

- [45] Lubricate the steering pivot bearings and the brake shaft bearings with BPW special longlife grease ECO-Li^{Plus} (arrows).

- [46] Install the axle.

- [47] Check the tracking: see chapter 15.

- [48] Make a functional check: see chapter 16.

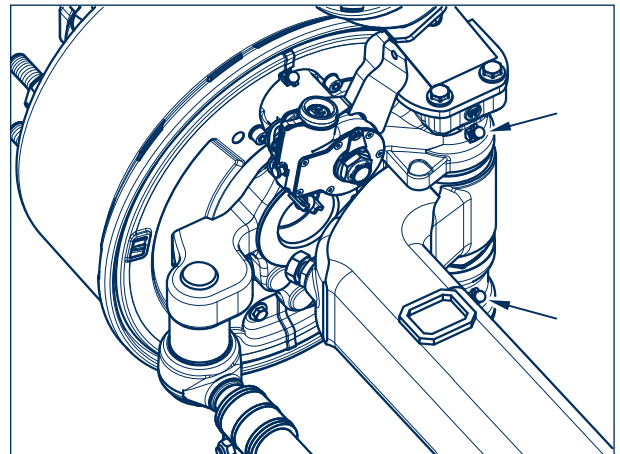

Picture 29

14 Steering pivot bearing

14.2 Steering pivot bearings, L series



Repair guide!

Check the vertical play of the steering pivot bearing. If the vertical play is $X > 6.2$ mm, the thrust washers (55, 56) are worn by 2.5 mm ($H = 19$ mm) each - the thrust washers must be replaced.

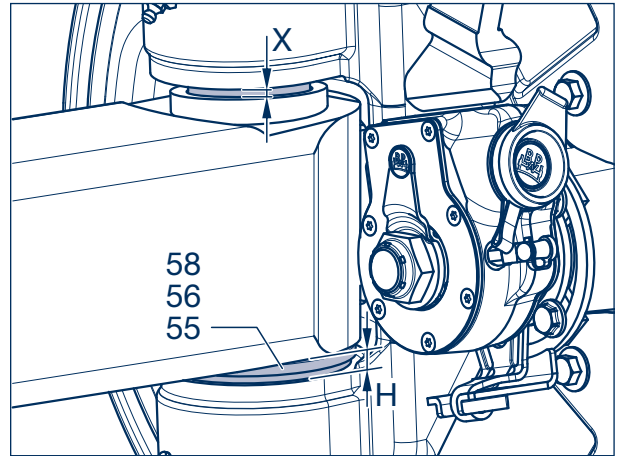

Picture 1

Removal

- [1] Remove the axle.
- [2] Take off the hubs and brake parts: see the manuals for the corresponding rigid axles.
- [3] Disassemble track rods, if present.
- [4] Remove the upper and lower closing plates (77) or base plate (190, 191).

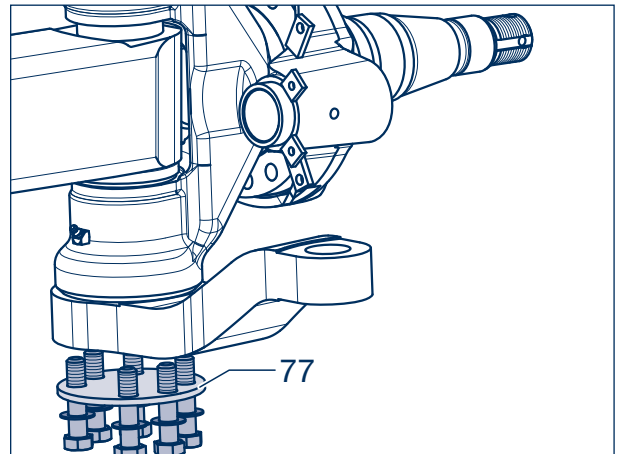

Picture 2

- [5] Place the steering axle beam with steering swivel (40, 41) in a press.
- [6] Exert slight pressure on the steering pivot (52) with a suitable mandrel.
- [7] Heat the stub axle on the end face with a large torch flame until the steering pivot (52) is loosened, then force it right out in one go with the press.



Repair guide!

If the steering pivot is pressed out without being heated, the steering swivel bore will be destroyed.

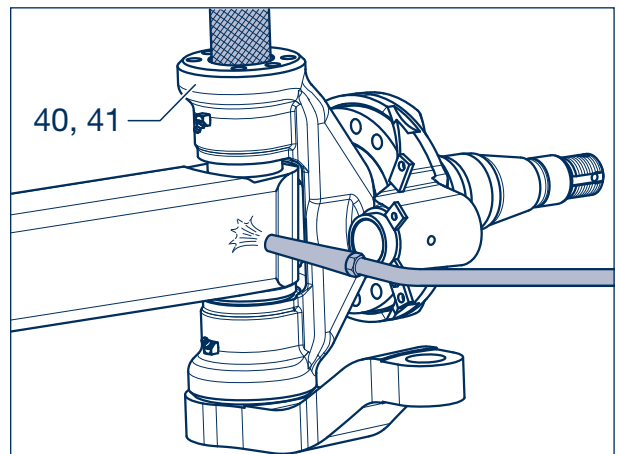

Picture 3

- [8] Remove the steering pivot (40, 41) with the thrust bearing (55, 56, 58) and starting with year of manufacture 1997 the ring (57) as well.

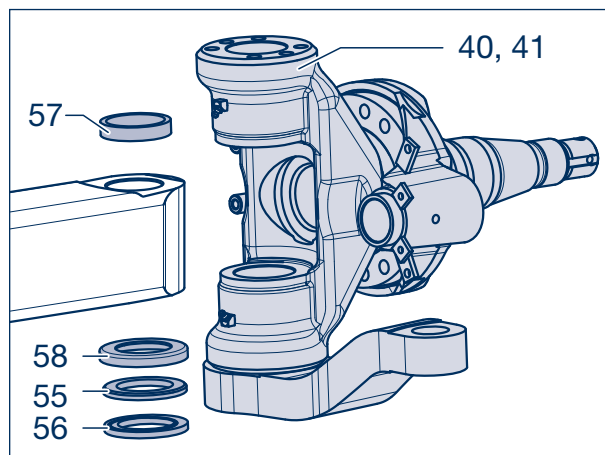

Picture 4

- [9] Check the thrust washers (55, 56) for wear.

Permissible wear is 2.5 mm per thrust washer:

New condition:

thrust washer (55) 7 mm

thrust washer (56) 7 mm



Repair guide!

The thrust bearing (55, 56, 58) wear can also be checked while it is mounted. In case the bearing play X exceeds 6.2 mm, the thrust washers must be replaced.

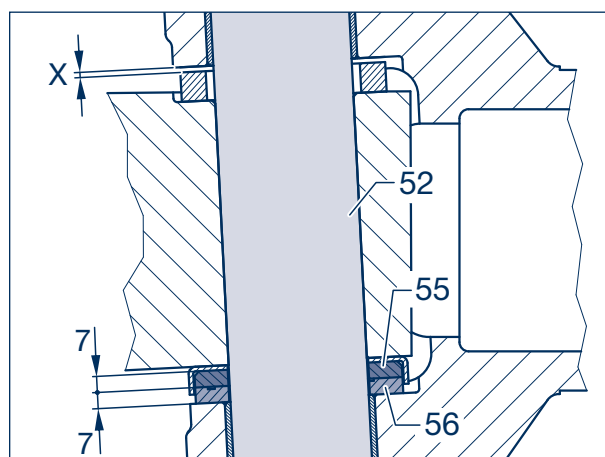

Picture 5

- [10] Inspect the steering pivot (52) and bushes (42) for wear. Make a visual inspection by opening up the upper and lower bearing points: the wear limit of the bushes (42) is reached at a wall thickness of 1.8 mm; if necessary exchange components.

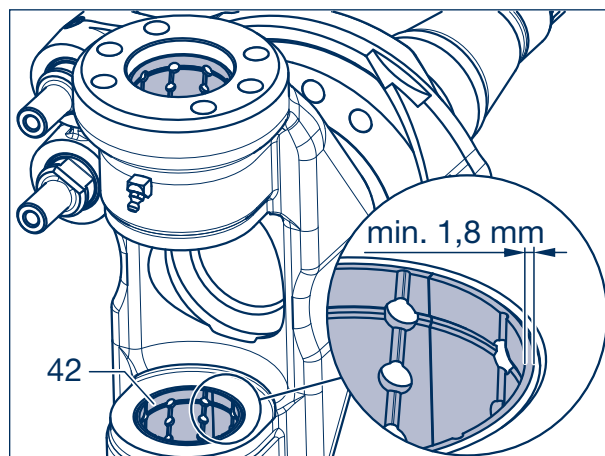

Picture 6

14 Steering pivot bearing

Installation

- [11] Press new bushes (42) for the steering pivot (52) in with a suitable mandrel carefully and without tilting them until they make full contact (2).



Repair guide!

The inner open lubrication passages (arrows) must face towards the middle of the axle.

- [12] Check whether the steering pivot (52) slides smoothly into the bushes (42), if necessary rework the bushes.

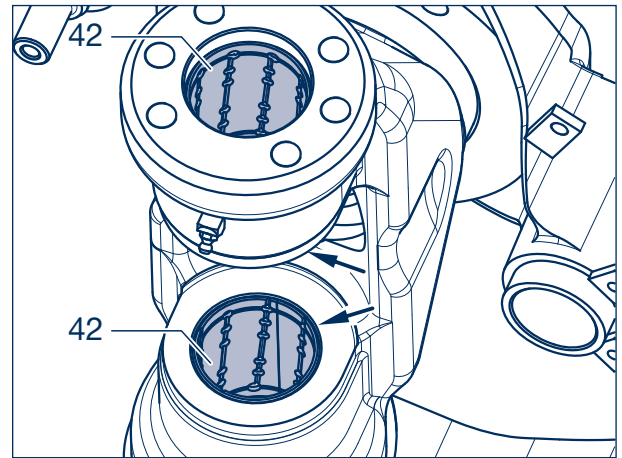

Picture 7

- [13] Grease the upper and lower thrust rings (55, 56) and place them together.
- [14] Place the upper thrust ring (55, without lubrication groove), with the exterior chamfer facing upwards, on the lubrication groove side of the lower thrust ring (56).
- [15] Place the cap (58) on both thrust rings.

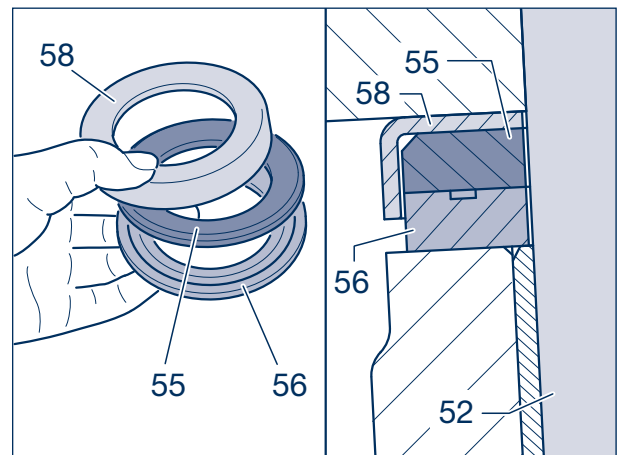

Picture 8

 Fit the axle upside down.

- [16] Place the complete thrust bearing with cap (58) on the stub axle on the axle beam so that the borings align.

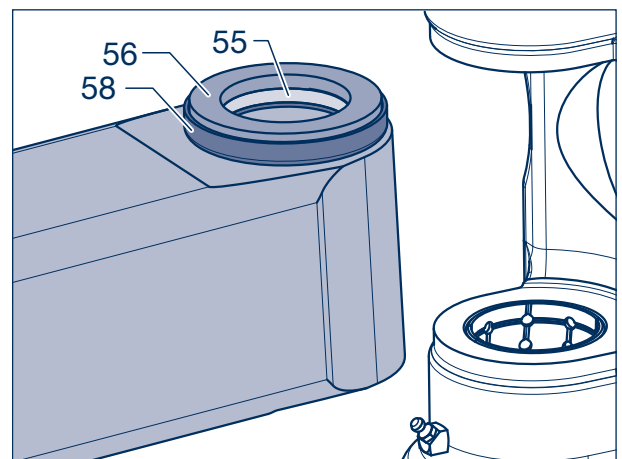

Picture 9

- [17] For steering axles manufactured after 1997, place the ring (57) on the steering pivot assembly (40, 41) so that the borings align.



Repair guide!

In the driving situation the thrust bearing must be below the steering axle beam with the cap (58) facing the axle beam.

- [18] Slide the steering swivel with the ring (57) onto the stub axle.

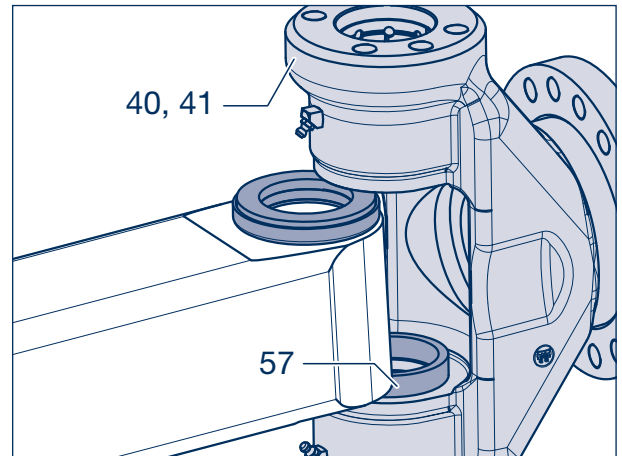

Picture 10

- [19] Put a distance washer of 55 x 9 mm dia in the top steering pivot bearing as an assembly aid. Attach the upper closing plate (77) with two screws (194).

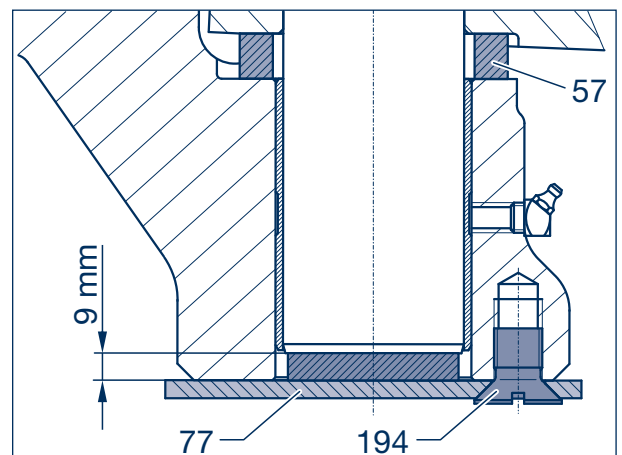

Picture 11

- [20] Align the steering swivel (40, 41) with the stub axle using a guide mandrel (approx. 0.1 mm thinner than the steering pivot).



Repair guide!

After withdrawing the guide mandrel, do not move the steering swivel (40, 41) any more.

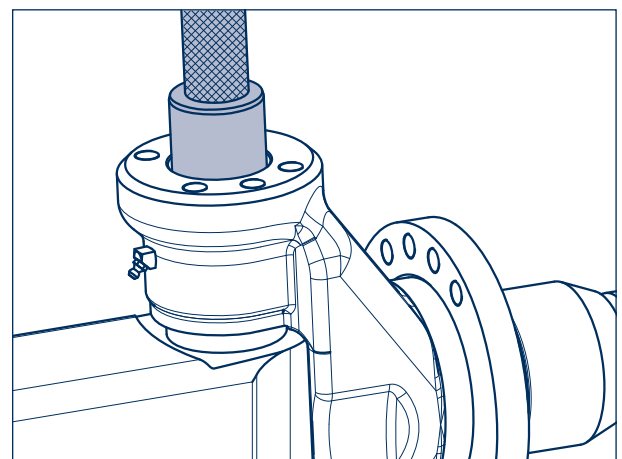

Picture 12

14 Steering pivot bearing

- [21] Heat the rear part of the stub axle on both sides in circles until it is dark red.

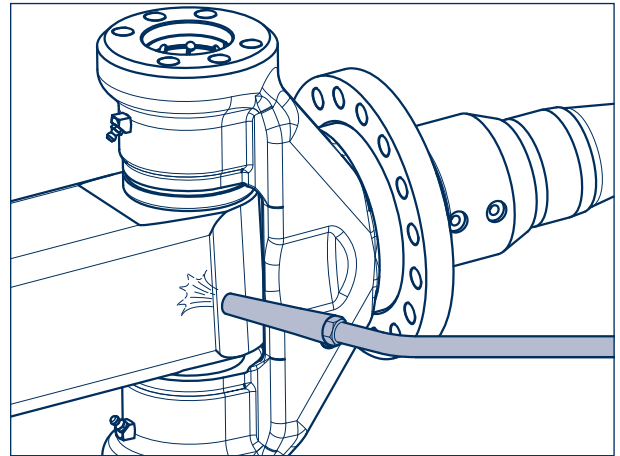

Picture 13

- [22] Drive the steering pivot (52) in as far as it goes, using light hammer blows if necessary.



Note:
To ease installation, the steering pivot can also be cooled down to approx. -30°C .

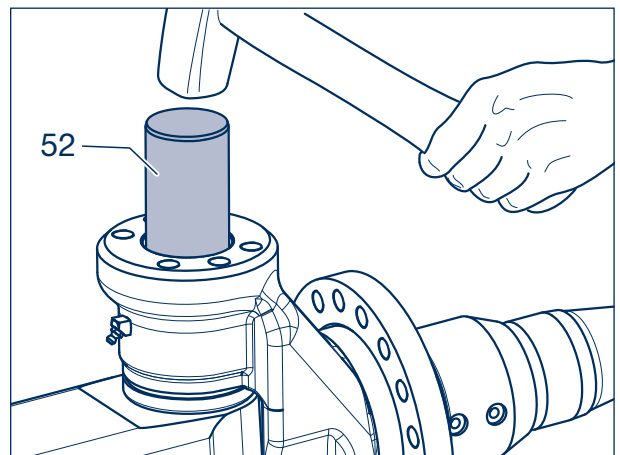

Picture 14

- ☞ Rotate axle back to installation position if necessary

- [23] Disassemble the closing plate (77) and remove the assembly aid.
- [24] Mount lower and upper locking plates (77) or air cylinder bracket (190, 191) with safety screws or hexagon bolts (194, 195, 196, 510) with spring washers (198, 199).

Tightening torques:

M 10 - 8.8 / SW 6	M = 38 Nm
M 10 - 10.9 / SW 15	M = 53 Nm
M 16 - 8.8 / SW 24	M = 163 Nm
M 16 - 10.9 / SW 22 / SW 24	M = 230 Nm

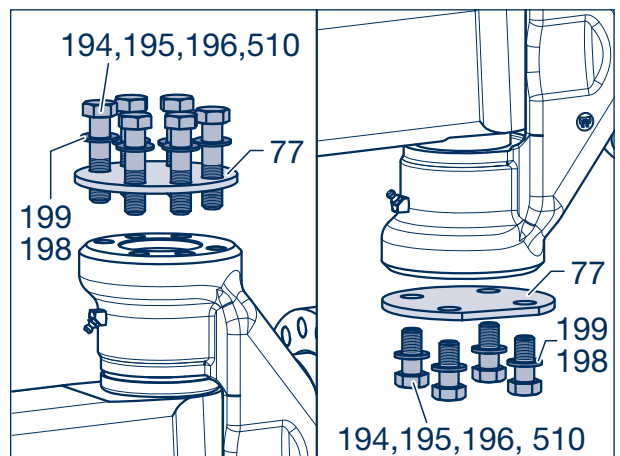

Picture 15

Fixing screws of adjustable brake cylinder base plate:

Pretension both safety screws to 150 Nm.
Tighten safety screws (195, SW 24) with the specified tightening torque of 280 Nm or in the case of new parts to 350 Nm.

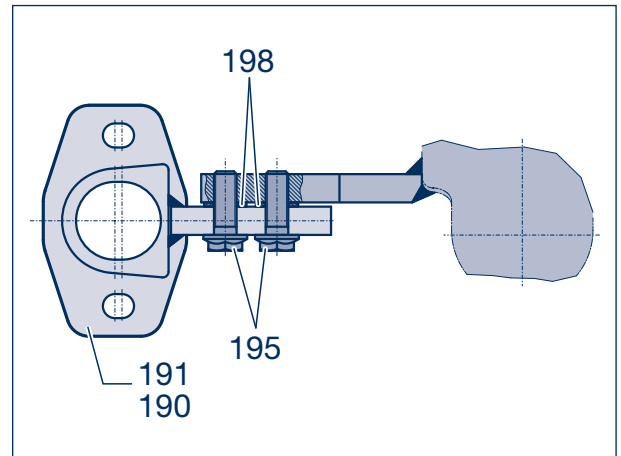

Picture 16



Repair guide!

In case of a flattening (arrow) on the locking plate (77), the flattening must point towards the air cylinder bracket (190, 191, picture 15) or to the brake drum (380), depending on the available space.

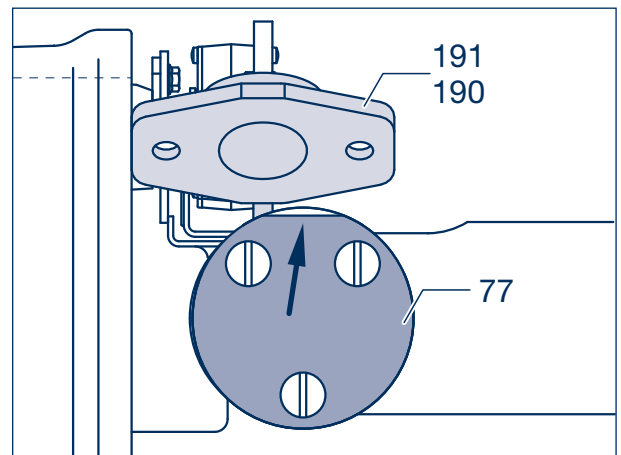

Picture 17

[25] Fit brakes and hubs.

[26] Lubricate the steering pivot bearings and brake shaft bearings with BPW special longlife grease ECO-Li^{Plus}.

[27] Install the axle.

[28] Carry out a tracking check: see chapter 15.

[29] Carry out a functional check: see chapter 16.

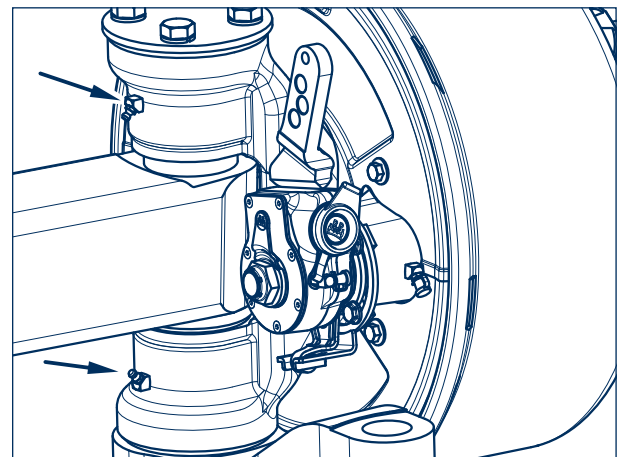

Picture 18

15 Tracking check

15.1 Checking and, if necessary, correcting toe-in (LL-series)



Note:

- The work is done with the axle removed from the vehicle.
- Measurements can also be made with the axle mounted under the vehicle after removing the wheels.
- For adjustment of toe-in on the LL series, it is absolutely essential for the thrust washers to be in their zero position.

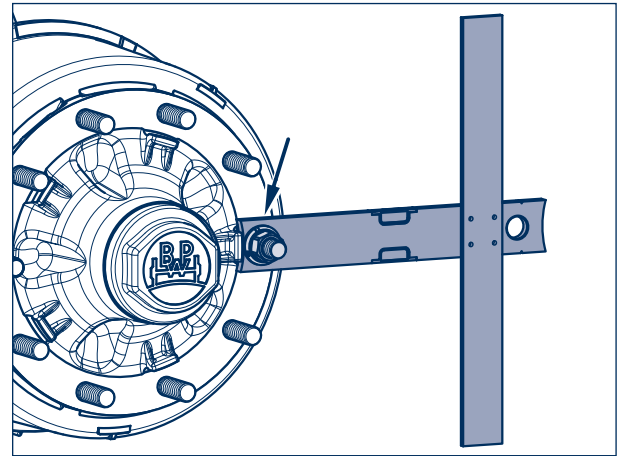

Picture 1

- [1] Screw the measuring tools onto a wheel stud on both sides of the axle (arrow).
- [2] Move both measuring tools horizontally forwards (arrow). Measure and note the distance **V** from measuring tool to measuring tool.
- [3] Make a similar measurement behind the axle. Note linear dimension **H**.

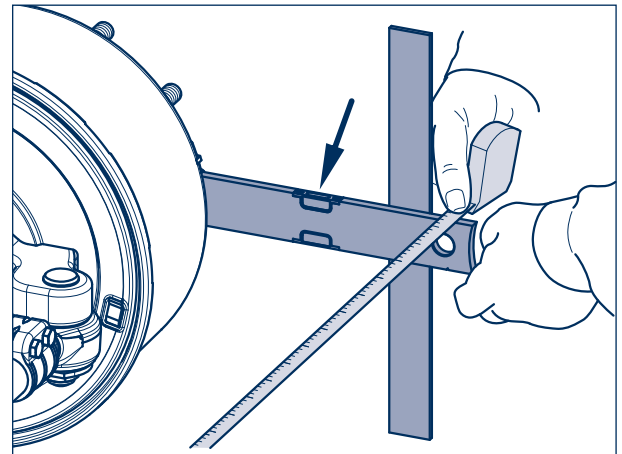

Picture 2

- [4] Insert both determined distance values **V** and **H** into the following formula (in case of rear track rod).

Drum brake: $3 \leq (H - V) \leq 4$

Disc brake: $-5 \leq (H - V) \leq -4$

- [5] Check whether the determined toe-in or toe-out values are within the specified tolerance values.

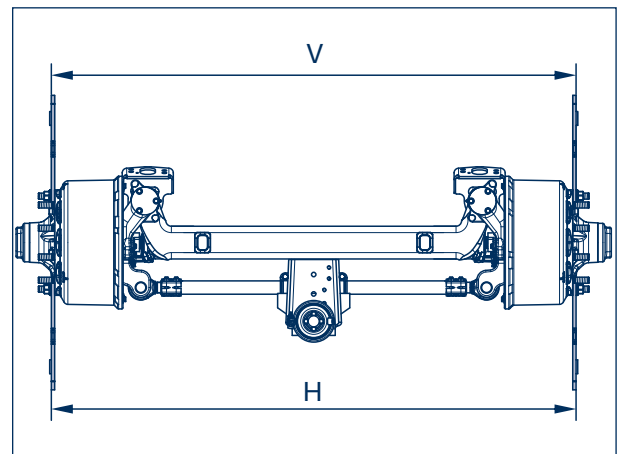

Picture 3

- [6] If the toe-in has to be corrected slightly, undo the clamping screws (163, SW 19) on the track rod ends (152, 153) and on the locking plate (160). If necessary, turn the track rod tube as required with a pipe wrench.
- [7] Check again and, if necessary, correct the distances in front of and behind the axle.

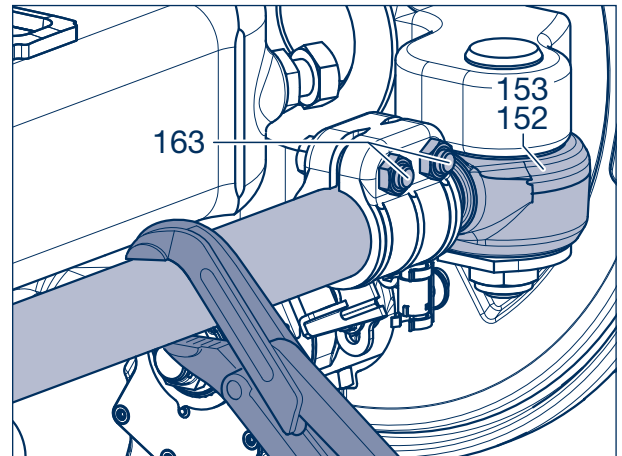

Picture 4

- [8] Again place the measuring tools in a horizontal position and take the same measurement diagonally to both sides.

**Repair guide!**

The difference between the two measurements may be up to 4 mm in the case of series LL steering axles. If the difference is exceeded, check the zero position of the thrust washers (55, 56).

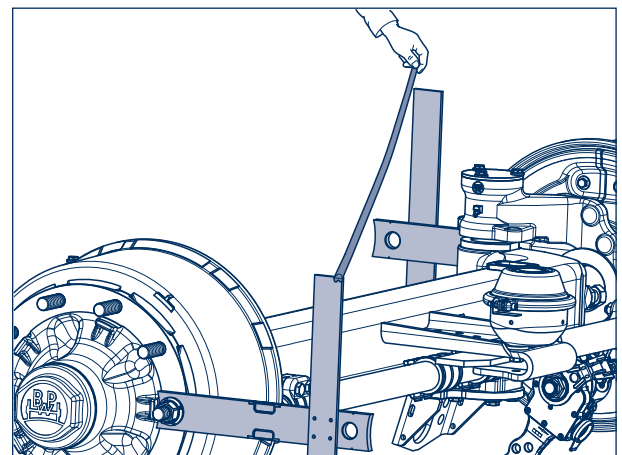

Picture 5

Steering axles with 3-part thrust washer:

- [9] Weld the thrust washers (55) in place according to the drawing. Protect neighbouring system parts from weld spatter and damages.

Rod electrode DIN EN 1600: E 18 8 Mn B 22
or alternatively:
cored-wire electrode ISO 17633-A T 18 8 Mn M M 2
solid-wire electrode ISO 14343-A G 18 8 Mn

Weld seam thickness: a 3.5 (DIN 1912)

- [10] Re-tighten the clamping screws (163) on the track rod heads (152, 153) and on the locking plate (160).
- [11] Remove the weld spatter.

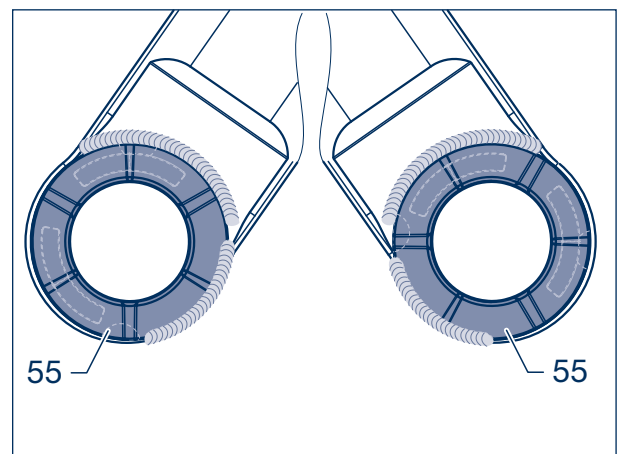

Picture 6

**Note:**

For series L steering axles the toe-in must be adjusted according to the instructions of the steering system manufacturer!

15 Tracking check

15.2 Conventional axle alignment check on the vehicle



Repair guide!

Begin measurements on tandem-axle vehicles at the front axle and on tri-axle vehicles at the centre axle (reference axle).



Repair guide!

For the tracking check it is absolutely essential that the steering swivel (40, 41) is in the zero position.

This is achieved on the LL version by exerting pressure on the steering box from below.

The steering lock must be engaged!



Note:

For units with new hub caps (460, embossed @, ECO or ECO Plus under the BPW logo) (Picture 1), as well as for ECO Plus 3, only the hub caps need to be uncrewed from the reference axle.

- [1] For old hub caps, as in picture 1, unscrew the hub cap and remove grease from the wheel hub.

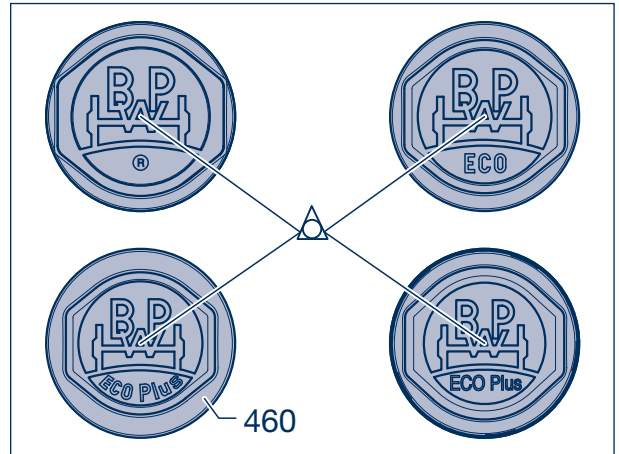

Picture 1

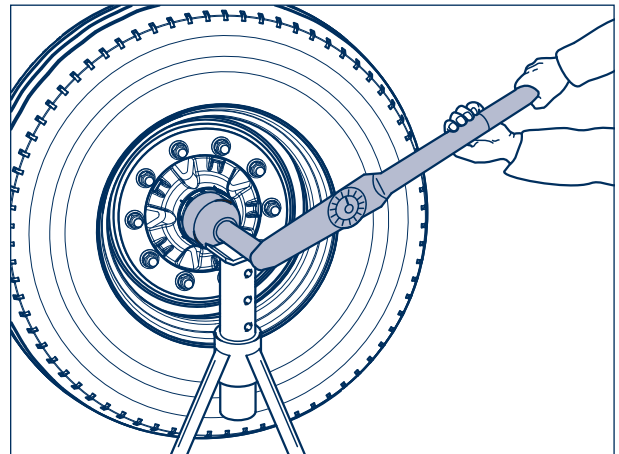

Picture 2

- [2] Measure the distance from the tracking rigid axle to the steering axle on both sides with centre-punches in the tri-angles of the hub caps or, in the case of old hub caps, in the dishes of the stub axles, permissible tolerance approx. 1 mm.

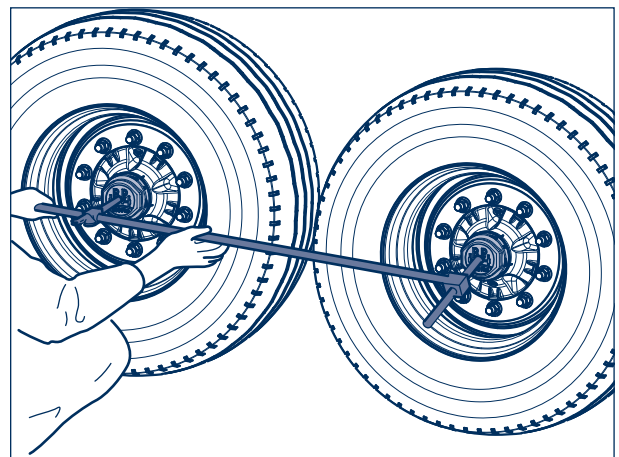

Picture 3

- [3] If the tolerance is exceeded, the axle must be aligned under the vehicle.

Adjustable hanger brackets:

- [4] To correct, slacken the lock nuts on the spring pivot bolt slightly and uniformly slide the connecting linkage on both sides, either upwards on the tracking-in direction, upwards or downwards with light hammer blows (see workshop manual BPW air suspension).

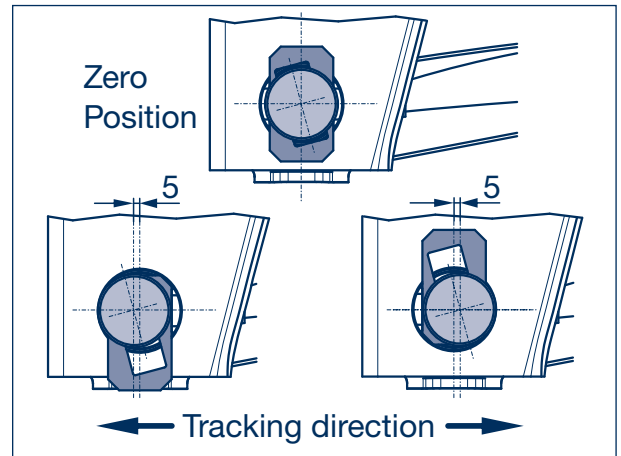

Picture 4

Rigid hanger brackets:

- [4] To make the correction, slacken the spring brackets. If present, grind down the weld seam on the track plates and align the axle by moving it (see workshop manual for the corresponding suspension).
- [5] Tighten the lock nuts of the spring brackets evenly and crosswise to the specified torque tension. If present, weld the track plate to the axle lip (see workshop manual for the corresponding suspension).

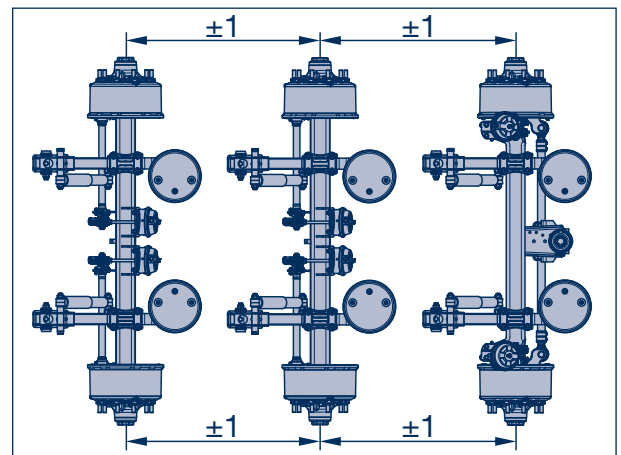

Picture 5

- [6] If old hub caps are disassembled, refill with some BPW special long durability grease ECO Li^{Plus}, if needed, and screw in with the specified torque.

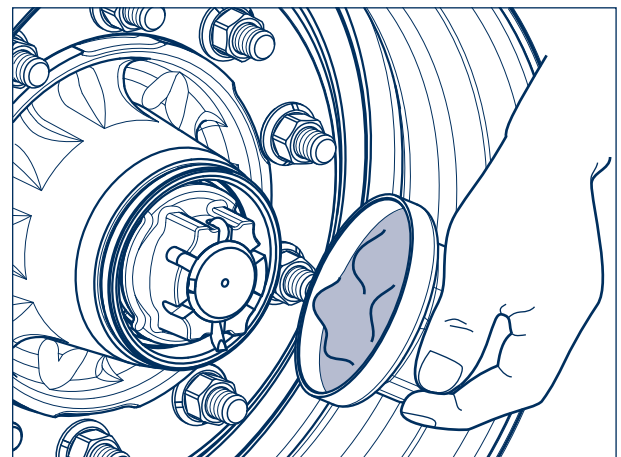

Picture 6

15 Tracking check

15.3 Axle alignment check on the vehicle with laser measurement devices

- [1] Set up the laser in accordance with the manufacturer's instructions. Make sure the axle is positioned horizontally, in order to avoid camber values falsifying the measuring results.

Calculating the toe values:

$$\text{Toe} = \frac{A1 - B1 \text{ (mm)}}{A \text{ (m)}}$$

Positive value = Toe-in
Negative value = Toe-out

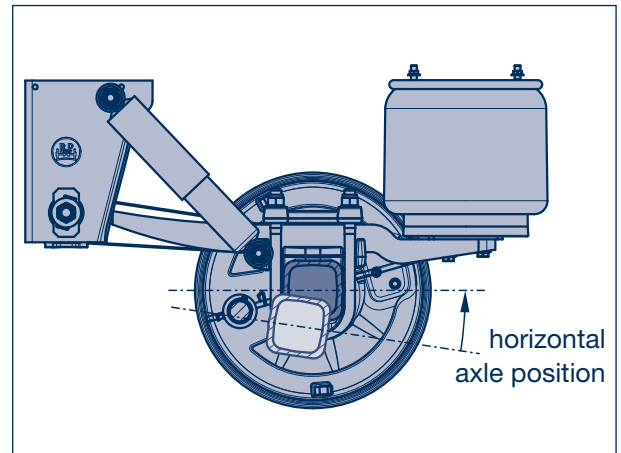

Picture 1

- [2] Take the measurement on both sides and add the measurements together. The total of the values is the toe-in/toe-out value of the axle and must be within the permitted tolerance range.

Permitted toe tolerance range per axle:

for rigid axles:	-1 to +5 mm/m
for LL axles	
unladen:	-2 to +2 mm/m
laden:	0 to +6 mm/m

- [3] Correct alignment in case of impermissible tolerance values (see workshop manual for respective suspension).

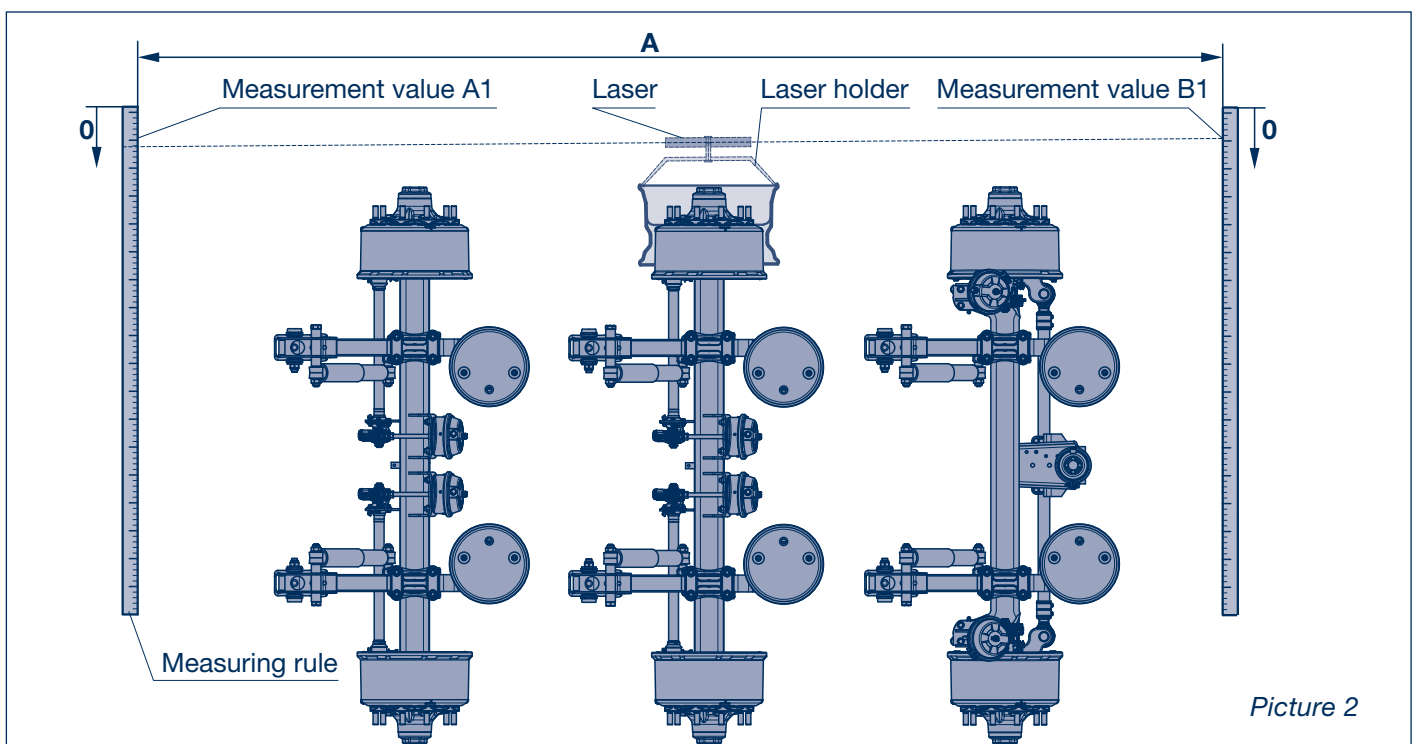

Picture 2

Functional check under the vehicle 16

- [1] Knock the axle into position on the left and right. Check for free movement and clearance of all moving parts.



Note:
Take the action of the vehicle springs into account!

- [2] If necessary, undo the lock nut (18, SW 30) of the stop screw (17). Turn the stop screw sufficiently and re-tighten the lock nut.
- [3] Tighten wheel nuts (479) crosswise with a torque wrench with the specified torque after the first loaded run.

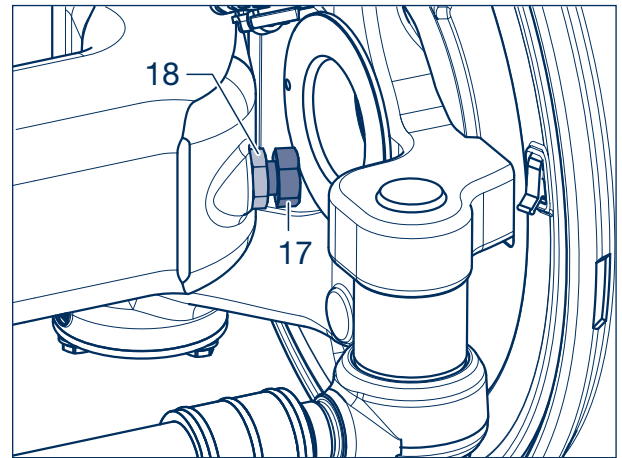

Picture 1



BPW-WH-LL-L 35351701e

BPW is a globally leading manufacturer of intelligent running gear systems for trailers and semi-trailers. As an international mobility and system partner, we offer a wide range of solutions for the transport industry from a single source, from axle to suspension and brake to user-friendly telematics applications.

We thereby ensure outstanding transparency in loading and transport processes and facilitate efficient fleet management. Today, the well-established brand represents an international corporation with a wide product and service portfolio for the commercial vehicle industry. Offering running gear systems, telematics, lighting systems, composite solutions and trailer superstructures, BPW is the right system partner for automotive manufacturers.

BPW, the owner-operated company, consistently pursues one target: To always give you exactly the solution which will pay off. To this end, we focus our attention on uncompromising quality for high reliability and service life, weight and time-saving concepts for low operating and maintenance costs as well as personal customer service and a close-knit service network for quick and direct support. You can be sure that with your international mobility partner BPW, you always use the most efficient method.

Your partner on the path to economic viability



BPW Bergische Achsen Kommanditgesellschaft

Postbox 12 80 · 51656 Wiehl, Germany · Phone +49 (0) 2262 78-0

info@bpw.de · www.bpw.de