

# Workshop manual

**BPW axle stub MVBF ST**  
**35.50.743.013 - 028**



**BPW axles stub with drum brake**  
**S-camshaft SN 4218**  
**ECO<sup>Plus</sup> hub bearing**

Valid: 01.01.2021

Subject to change without notice.

Current versions and additional information can be found online at [www.bpw.de](http://www.bpw.de).

---

# Contents

◎ <b>1. Product identification</b> .....	<b>Page 4</b>
1.1 Explanation of BPW axle type codes .....	Page 4
1.2 Explanation of BPW axle code numbers .....	Page 4
◎ <b>2. Installation instructions</b> .....	<b>Page 5</b>
◎ <b>3. Exploded view</b> .....	<b>Page 6</b>
◎ <b>4. Safety regulations, safety information</b> .....	<b>Page 8</b>
4.1 Safety regulations.....	Page 8
4.2 Safety information .....	Page 9
◎ <b>5. Tightening torques</b> .....	<b>Page 10</b>
◎ <b>6. Special tools</b> .....	<b>Page 11</b>
◎ <b>7. Lubrication and maintenance work</b> .....	<b>Page 14</b>
◎ <b>8. Changing the brake lining</b> .....	<b>Page 23</b>
8.1 Removal of the wheel hub brake drum unit .....	Page 23
8.2 Changing the brake lining .....	Page 24
8.3 Riveting check .....	Page 27
8.4 Brake shoe installation .....	Page 28
8.5 Installation of the brake shoes .....	Page 30
8.6 Installation of the wheel hub brake drum unit .....	Page 32
◎ <b>9. Dismantling and assembling the hub unit</b> .....	<b>Page 35</b>
◎ <b>10. ABS / ABV</b> .....	<b>Page 42</b>
◎ <b>11. Brake camshaft</b> .....	<b>Page 43</b>
◎ <b>12. Automatic slack adjuster ECO-Master</b> .....	<b>Page 46</b>

# 1 Product identification

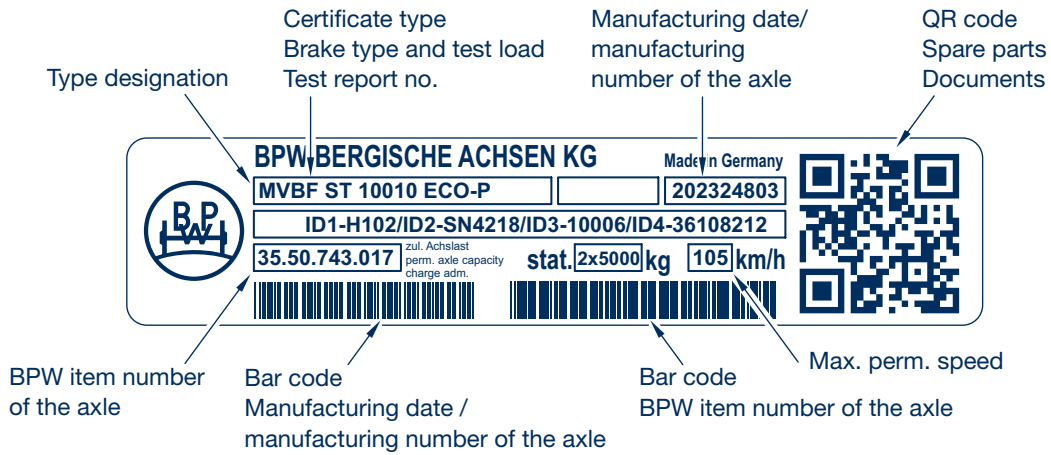

Note:

The rating plates of the stubs axles are supplied loose and must be affixed in the visible area of the axle stub.

## 1.1 Explanation of BPW axle type codes

Example:								
M	V	B	F	ST	10010	LKS	ECO <sup>Plus</sup>	
				Axle series	Axle beam	Brake	Tyre	
M					M..	●	SN 4218	20" - 24"
	V				Brake drum in front of the wheel hub			
		B			For single wheels, wheels with offset			
			F			Wheel studs M 22 x 1.5 without wheel nuts, order wheel nuts for stud or spigot alignment separately		
				ST	Axle stub			
					10010	Axle load (kg) + quantity of wheel studs per hub		
						RTS	Right axle side	
						LKS	Left axle side	
						ECO <sup>Plus</sup>	Trailer axle with ECO <sup>Plus</sup> Unit	

## 1.2 Explanation of BPW axle code numbers

Example:			
35.	50.	743.	013
Axle type			
35.	Axel stub		
		<b>Axle load</b>	<b>Roller bearing</b>
	50.	10000 - 12000 kg	33118 / 33213
		<b>Bearing generation</b>	ECO <sup>Plus</sup> Unit
		<b>Wheel brake type</b>	<b>Dimension</b>
		743.	SN 4218 BPW 95 closed
			Ø 420 x 180
			Brake shoes with split roller
		013	Consecutive number 000 - 999

# Installation instructions **2**

- During welding work on the axle stub, it is necessary to ensure that no temperatures in excess of 110 °C are reached in the seal area.
  - The installation of the slack adjuster can be configured for pulling and pushing actuation.
  - Make sure that the 0 stroke position of the brake cylinder is maintained when driving, except when braking. Shocks during driving are not allowed to result in binding or even spontaneous braking. Push or pull rods connected to the slack adjuster in addition to the brake cylinder must be mounted without vibration.
  - In the configuration of the actuation device, attention must be paid to ensuring a 90° angle is achieved between the push rod of the brake cylinder and the line of symmetry of the slack adjuster then the cylinder is at half stroke.
  - The slack adjuster spline on the camshaft is designed for the ECO-Master unit (26.75 mm).
-

### 3 Exploded view / Name

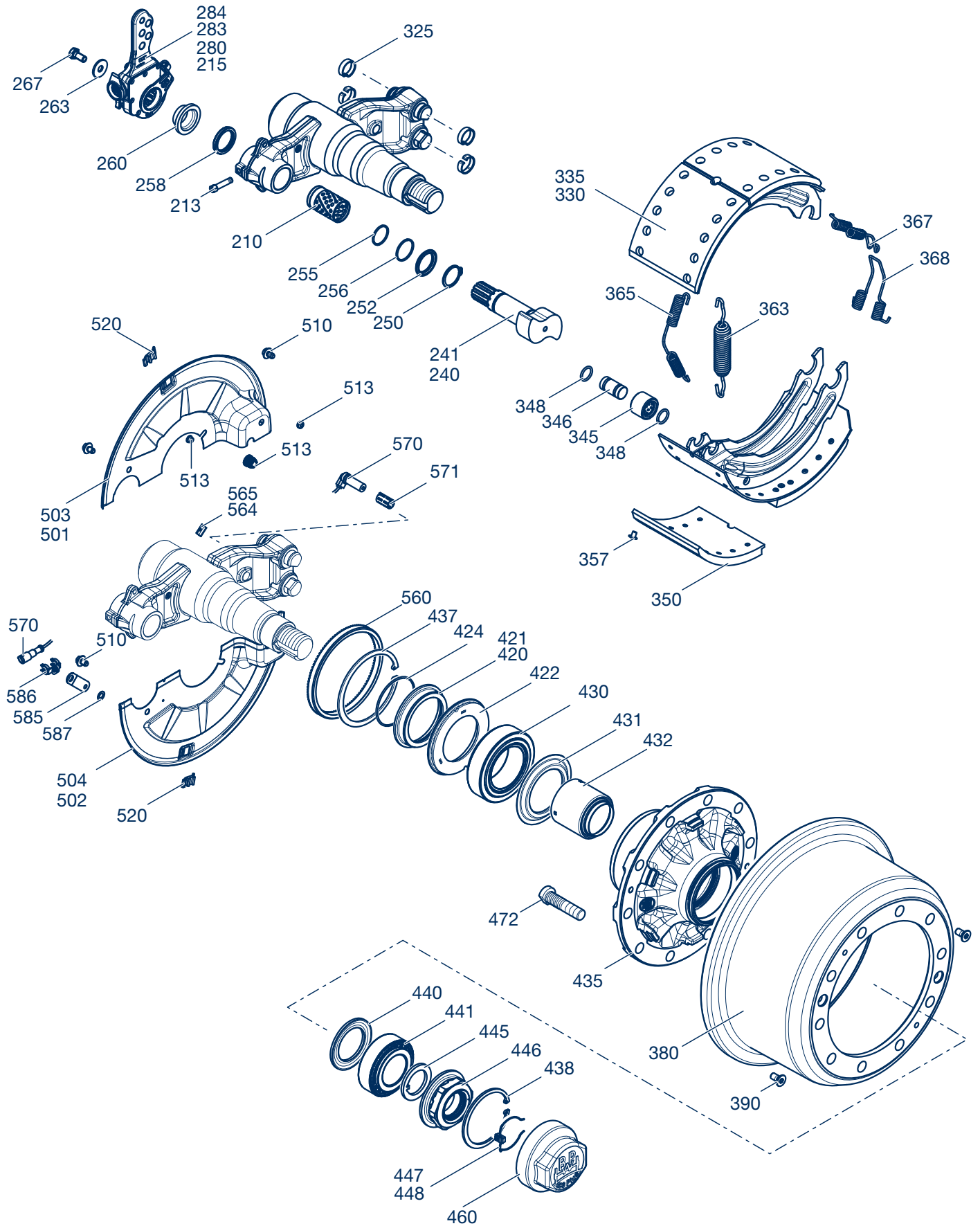

**Brake camshaft bearing**

Pos.	Name
210	Bush
213	Threaded sleeve
240	Brake camshaft, left
241	Brake camshaft, right
250	Locking ring
252	Ring
255	O-ring (black)
256	O-ring (green)
258	Sealing ring
260	Sleeve
263	Washer
267	Hexagon screw

**Slack adjuster**

Pos.	Name
215	Cover
280	Slack adjuster
283	Cap
284	Grease nipple

**Brake shoes**

Pos.	Name
325	,C' Clip
330	Brake shoe assembly, with lining
335	Brake shoe assembly, without lining
345	Roller
346	Bolt
348	Ring
350	Brake lining
357	Rivet
363	Return spring
365	Return spring
367	Return spring (hook)
368	Return spring (eye)

**Wheel hub bearing**

Pos.	Name
380	Brake drum ECO Drum
390	Countersunk screw
420	Thrust washer cpl.
421	Thrust washer ECO <sup>Seal</sup>
422	Oil seal ECO <sup>Seal</sup>
424	O-ring
430	Roller bearing
431	Dust cover (grease retention plate)
432	Seal
435	Hub
437	Locking ring
438	Locking ring
440	Thrust washer
441	Roller bearing
445	Washer
446	Axle nut
447	Locking piece
448	Hooked spring ring
460	Hub cap

**Wheel connection**

Pos.	Name
472	Wheel stud ( helical fit wheel stud )

**Dust cover**

Pos.	Name
501	Dust cover, left upper
502	Dust cover, left lower
503	Dust cover, right oben
504	Dust cover, right lower
510	Locking screw
513	Plug (white)
513	Plug (black)
513	Cable grommet
520	Plug

**ABS**

Pos.	Name
560	Exciter ring
564	Clamp
565	Drive pin
570	Sensor
571	Bush for ABS
585	Support
586	Retaining clip
587	Serrated lock washer

## 4 Safety regulations, safety information

### 4.1 Safety regulations

- All work must be performed by trained mechanics at competent repair facilities or authorized specialist companies who have access to all relevant tools and have acquired the know-how required for this work. Anyone who performs maintenance and repair work must be trained in automotive mechanics and already have experience in repairing trailers. Anyone who performs brake work must be trained in brake systems.
  - Comply with local safety regulations.
  - The relevant operation and service regulations as well as safety regulations of the vehicle manufacturer and of the manufacturers of other vehicle parts must be adhered to.
  - The dust created from grinding brake pads comprises particulate matter that can cause lung damage. A safety mask must therefore be worn to prevent brake dust from being inhaled.
  - Use prescribed dust washing devices or vacuum cleaners for cleaning, never use compressed air or other high-pressure devices.
  - Ensure adequate ventilation at the workplace.
  - The vehicle must be prevented from moving during repair work. Please observe the relevant safety regulations for repair work on commercial vehicles, in particular the safety regulations for jacking up and securing the vehicle.
  - During repair work, make sure that the brake is not operated inadvertently.
  - Do not perform repair work unless wearing protective clothing (gloves, safety boots, safety goggles, etc.) and using the recommended tools.
  - Only use recommended tools.
  - A second mechanic must provide assistance when working with heavy components (brake drums or brake removal/installation).
  - All air lines and components must be depressurised before being removed.
  - Following each repair, perform a function check or a test drive in order to make sure that the brakes are functioning correctly. New drums and pads only have maximum effect after a few braking actions. Avoid hard braking.
  - All exchanged components must be reused or disposed of in accordance with the applicable environmental regulations, laws and directives.
  - The remaining thickness of the brake lining and the condition of the brake drum (see page 20) must be visually inspected at regular intervals with respect to the way in which the vehicle is used.
  - Tighten screws and nuts with the prescribed tightening torque.
-



## Safety information 4.2

This workshop manual contains different types of safety instructions, each of which is designated an icon and a signal word. The signal word describes the severity of the potential danger.



Danger!  
Warning!  
Caution!

**Immediate** potential danger of serious or fatal injury. (severe injury or death).  
**Possible** potential danger of serious or fatal injury. (severe injury or death).  
**Possible** dangerous situation (slight injury or damage to property).



Repair Guide!

Risk of damage to property or consequential damage if this information is not observed.



Note!

Application hints and especially useful information.



Mandatory!

Do not use an impact wrench; doing so would cause considerable damage!

It is essential that all maintenance work is carried out in accordance with the prescribed intervals in order to maintain the safe operation and roadworthiness of the trailer.

Rectification of any defects which are discovered or replacement of worn parts should be carried out by a BPW Service Centre or BPW Direct Service Partner unless the vehicle owner has the facilities, equipment and workshop manuals and possesses an official certificate to perform interim inspections or special brake inspections.

When installing spare parts, it is strongly recommended that only original BPW components are used. Parts approved by BPW for trailer axles and suspensions regularly undergo special test procedures and as a result BPW is able to guarantee their quality.

However, BPW cannot assess every single third-party product as to whether it can be used for BPW trailer axles and suspensions without any risk to safety. This applies even if such products have already been tested by an accredited test authority.

The warranty becomes null and void if spare parts other than original BPW parts are used.

## 5 Tightening torques

Pos.	Description	Thread / Spanner size	Tightening torque
460	Hub caps according to stamped tightening torque on face of cap BPW form Caps for ECO <sup>Plus</sup> Unit 8 - 12 t	M 136 x 2.5 / SW 110	M = 800 Nm
446	Axle nut		see page 18
479	Wheel nuts Wheel stud alignment Wheel centre alignment	M 22 x 1.5 / SW 32 M 22 x 1.5 / SW 32	M = <b>510 Nm</b> (485 - 535 Nm) M = <b>630 Nm</b> (600 - 660 Nm)
410, 411	Attachment nuts for brake cylinder	M 16 x 1.5 / SW 24	M = <b>180 Nm</b> (180 - 210 Nm)
	Compressed air connections on brake cylinder	M 16 x 1.5 / SW 24	M = 45 Nm
	Spring „hold off“ bolt on spring brake cylinder		M = <b>40 Nm</b> (30 - 50 Nm)
267	Lock nut for slack adjuster	M 12 x 25 / SW 19	M = 69 Nm
390	Hex socket countersunk screw for brake drum fixing	M 12 x 25 / SW 8	M = 66 Nm
510	Locking bolt on cover plates	M 10 / SW 13	M = 43 Nm
551	Self cutting bolt for sensor holder	M 8 / SW 13	M = 25 Nm
288	Hexagon bolts on bearing box (Tensilock)	M 8 / SW 13	M = 28 Nm
	Hexagon bolts on bearing box	M 8 / SW 13	M = 23 Nm

# Special tools 6

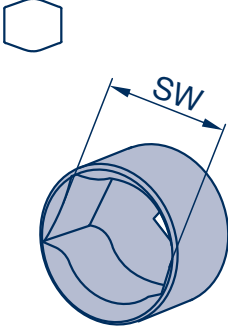
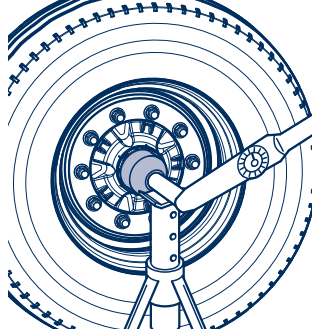
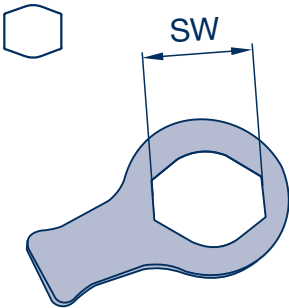
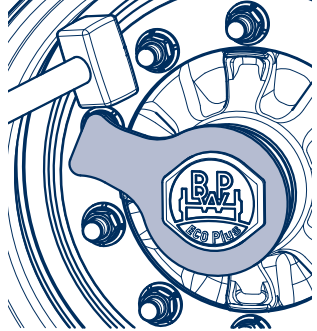
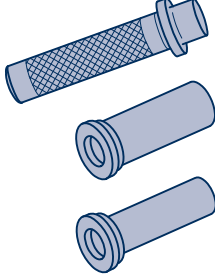
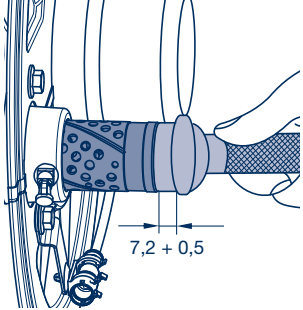
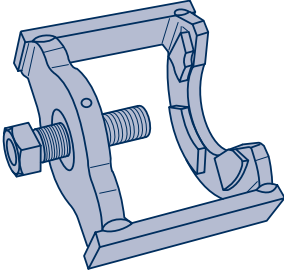
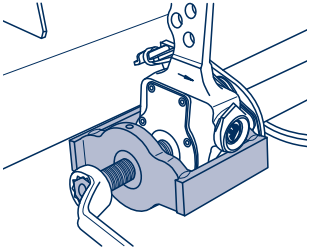
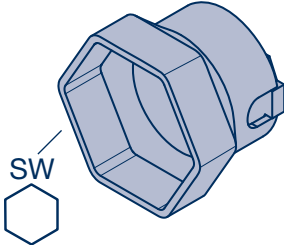
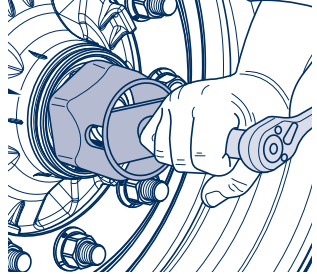
Number	Description	Illustration of tool	Tool in operation
1	Sockets for hub caps  BPW code number: <b>03.364.29.03.0</b> SW 110		
2	Ring spanner for hub caps (flat shape)  BPW code number: <b>03.339.05.04.0</b> SW 110		
3	Driving mandrel set for bearing bushes (camshaft and brake pins)  BPW code number: <b>05.001.04.04.0</b>		
4	Puller for slack adjusters  BPW code number: <b>02.4306.15.00</b>		
5	Sockets for axle nuts  BPW code number: <b>05.364.26.05.0</b> SW 95		

## 6 Special tools

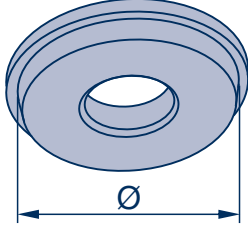
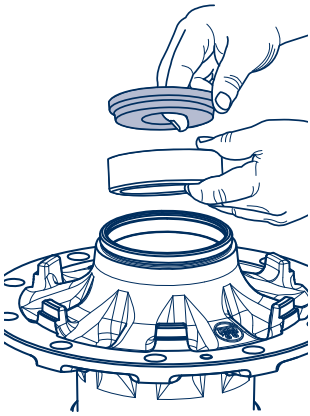
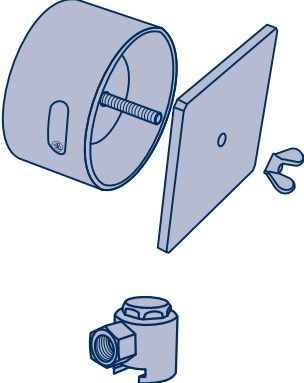
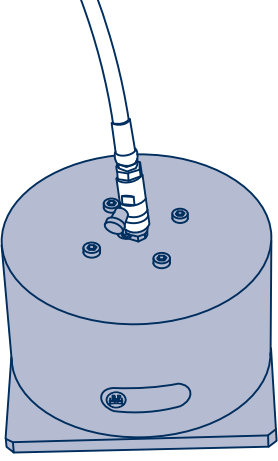
Ifd. Nr.	Description	Illustration of tool	Tool in operation
6	<p>Press tools, for inserting the outer rings of roller bearings</p> <p>BPW code number: roller bearing</p> <p><b>15.011.20052</b>    Ø 142 33118</p> <p><b>15.013.20052</b>    Ø 113 33213</p>		
7	<p>Greasing tools for roller bearings</p> <p>BPW code number: roller bearing</p> <p><b>99.00.000.9.55</b>    33118 / 33213</p> <p>Complete set including adapter for flat grease nipple</p>		



# 7 Lubrication and maintenance work

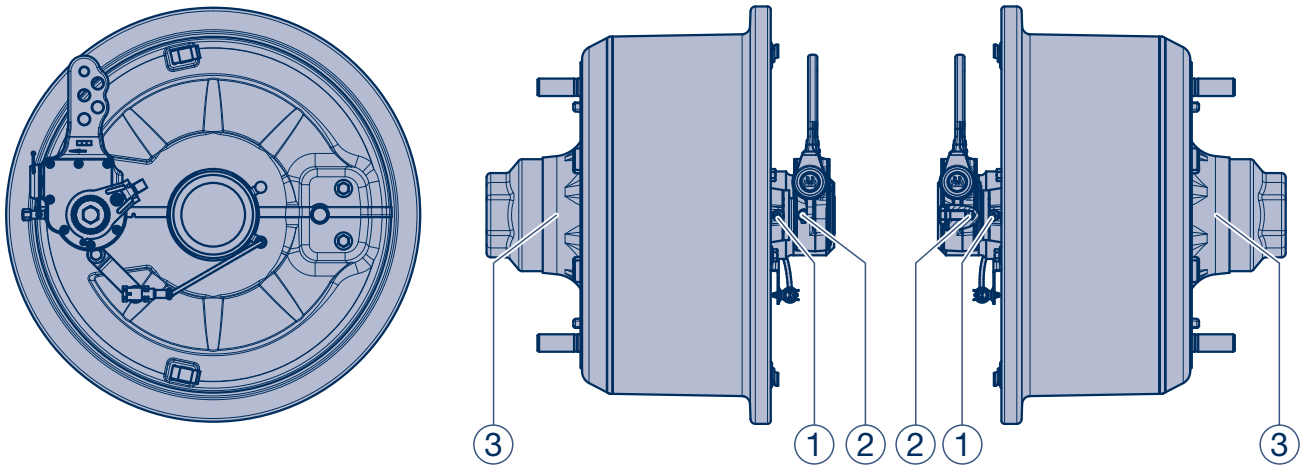

## Lubrication

### Overview

For detailed description see pages 16 to 18

○ Lubrication with BPW special longlife grease ECO-Li<sup>Plus</sup>

	Every 26 weeks <sup>1) 2)</sup>	Annually and at every brake lining replacement <sup>1) 2)</sup>	Annually	Every 2 years	Every 3 years	After 5 years, there-after every 3 years
① Brake camshaft bearing	①					
② Automatic slack adjuster ECO-Master						
On-Road conditions		②				
Off-Road conditions	②					
Outside Europe	②					
③ Change wheel hub bearing grease, check taper roller bearings and rotary shaft seal for wear.						
On-Road conditions						③
Off-Road conditions					③	
Outside Europe: On-Road conditions				③		
Outside Europe: Off-Road conditions			③			

<sup>1)</sup> After a long idle period, prior to initial operation actuate the brake lever and lubricate the brake camshaft bearing.

<sup>2)</sup> With usage extreme conditions (e.g. extreme Off-Road use) more frequent lubrication with high pressure grease is necessary.

For the positions ① to ② the use of a high-pressure central lubrication system which is capable of feeding special longlife grease of consistency class 2-3 is permissible. The use of liquid lubricants is not permitted!

BPW recommends using lubricating lines made from high pressure-resistant material at points which are difficult to access (slack adjuster and brake camshaft bearing), and to make sure that the connection points are securely attached.

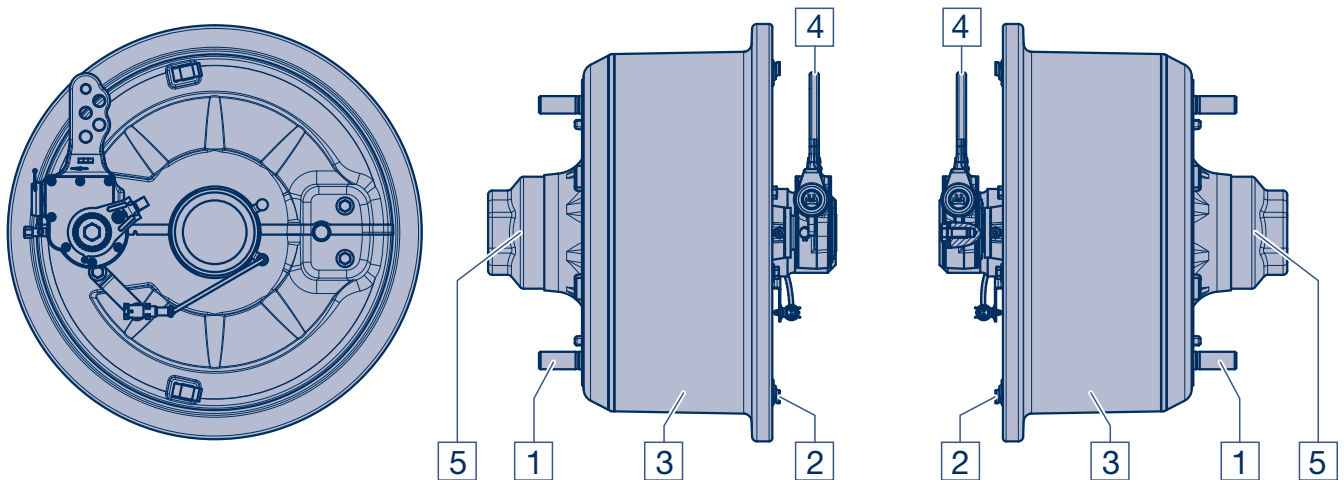

### Maintenance work

#### Overview

For detailed description, see pages 19 to 22

Maintenance

	Initially	Every 12 weeks	Every 26 weeks <sup>2)</sup>	Annually and at every brake lining replacement <sup>2)</sup>
<input type="checkbox"/> 1 Check wheel nuts for tightness.	<input type="checkbox"/> 1 <sup>1)</sup>			
<input type="checkbox"/> - Check the tyres for uneven wear, adjust the inflation pressure if necessary according to the manufacturer's specifications.		<input type="checkbox"/> -		
<input type="checkbox"/> 2 Check brake lining thickness is at least 5 mm.		<input type="checkbox"/> 2		
<input type="checkbox"/> 3 Check the brake drum for cracks and check the internal diameter.		<input type="checkbox"/> 3		
<input type="checkbox"/> o Visual inspection of all component parts and welding seams for damage and wear.		<input type="checkbox"/> o <sup>3)</sup>	<input type="checkbox"/> o	
<input type="checkbox"/> 4 Check operation of automatic slack adjusters.		<input type="checkbox"/> 4 <sup>3)</sup>	<input type="checkbox"/> 4	
<input type="checkbox"/> 5 Check wheel hub bearing play, adjust if necessary.				<input type="checkbox"/> 5

<sup>1)</sup> After the first run under load conditions, likewise after each wheel change.

<sup>2)</sup> Under extreme conditions, increase frequency (e.g. construction sites and poor roads).

<sup>3)</sup> For use outside Europe.

Note: Components that have damage due to improper mounting are to be exchanged after a review by a BPW Service Centre.

## 7 Lubrication and maintenance work

### ○ Lubricate

Note: After cleaning the vehicle with high pressure cleaners, all lubrication points must be relubricated.

#### ① Brake camshaft bearing – every 6 months –

**Prevent the vehicle from rolling away.  
Release the service brakes and the handbrake.**

Lubricate the brake camshaft bearing through the grease nipple with BPW special longlife grease **ECO-Li<sup>Plus</sup>** until fresh grease emerges from the bearing points.



**Repair guide!**  
Use of other grease is not permitted.

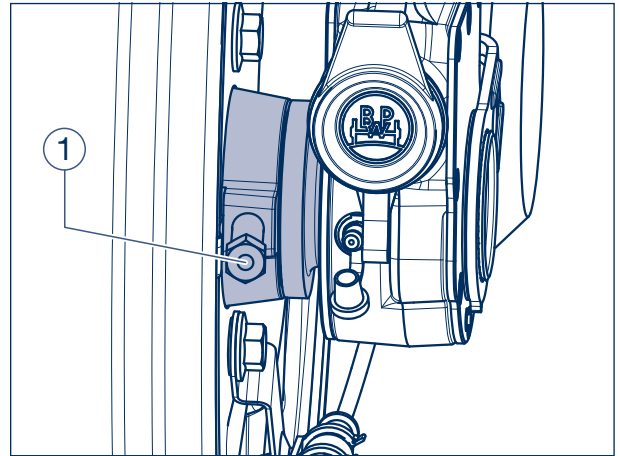

#### ② Automatic slack adjuster ECO-Master – every year and with each brake lining change in On-Road use – – every 6 months for Off-Road use and in use outside Europe –

Remove rubber seal cap. Grease with BPW special longlife grease **ECO-Li<sup>Plus</sup>** (approx. 80 g) until sufficient new grease emerges from the adjustment screw.

Turn back adjustment screw (keep clutch sleeve pressed down) by approx. one turn using a ring spanner. Actuate the brake lever several times by hand. The adjustment must be carried out smoothly. If necessary, repeat several times.

Once again only use BPW special longlife grease **ECO-Li<sup>Plus</sup>**.

Adjust the brake, see page 47.

Replace seal cap.

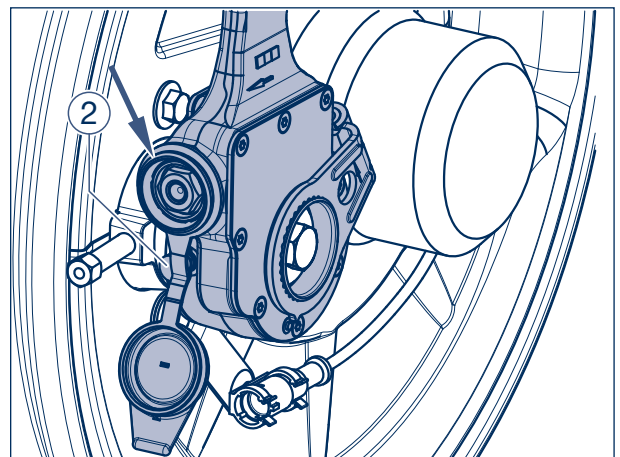



### 3 Change wheel hub bearing grease

#### **ECO<sup>Plus</sup> Unit**

- for the first time after 5 years in on-road use, or every 3 years in off-road use in Europe, then at least every 3 years depending on operating conditions –
- every 2 years in on-road use or every year in off-road use outside Europe –

Remove and dismantle wheel hubs, see chapter 8/9.



#### **Repair guide!**

**Mark both the hub and bearing to ensure correct positioning during re-assembly.**

**It is essential for the bearing inner races and rollers to be re-inserted in the same hubs.**

Clean taper roller bearings and seals (using e.g. diesel oil) thoroughly, dry and check for re-useability. Replace oil seal.



#### **Recommendation:**

**Renew the tapered roller bearings after 5 years in on-road use and after 3 years in off-road use.**

Work BPW special longlife grease **ECO-Li<sup>Plus</sup>** thoroughly into the cavities between the taper rollers and the cage in both taper roller bearings. (For grease quantity see illustration on page 18.) Smear any residual grease into the hub's outer bearing race.

Smear the lip of the new seal all round with BPW special longlife grease **ECO-Li<sup>Plus</sup>**.

Thoroughly clean the bearing journals of the axle stub with a microfibre cloth. The journals must be bright, dry and free from grease.

Apply **Castrol White T** using a fine bristled brush evenly and thinly to the bearing journals. Ensure that the bearing journal is completely coated. Castrol White T must not be diluted.

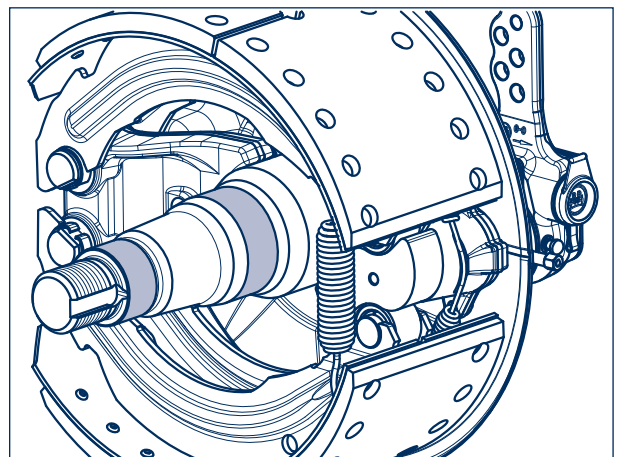
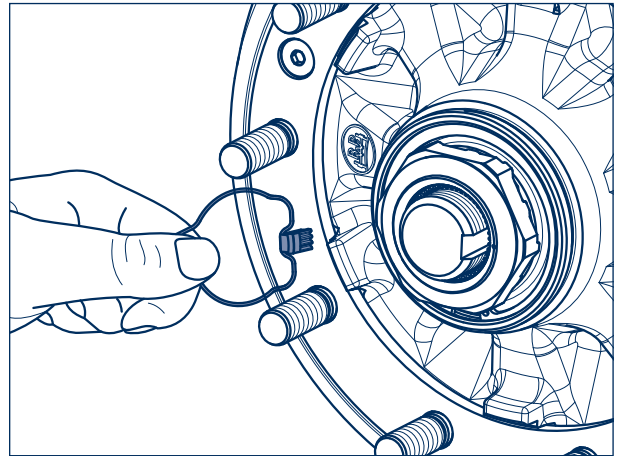

## 7 Lubrication and maintenance work

Fasten axle nut using a hexagon socket spanner whilst rotating the ECO hub unit. It should take several turns until the clutch on the axle nut slips.



**Important!**  
Do not use an impact driver.

Fit the retaining key in the groove between the axle stub and the nut (do not reset the axle nut).

Insert the hooked spring ring behind the edge of the axle nut.

Screw on the cap and tighten to 800 Nm.

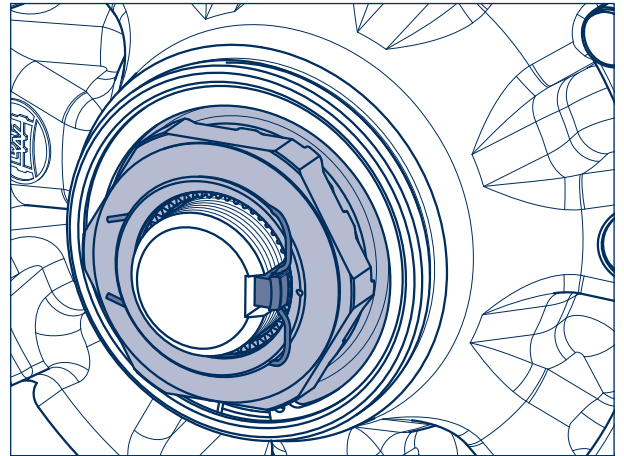

	BPW special longlife grease ECO-Li <sup>Plus</sup>	
	Grease quantity per taper roller bearing	
	① inner bearing	② outer bearing
Manual greasing	170 g	120 g
Greasing with a grease applicator	130 g	90 g

### ECO<sup>Plus</sup> Unit

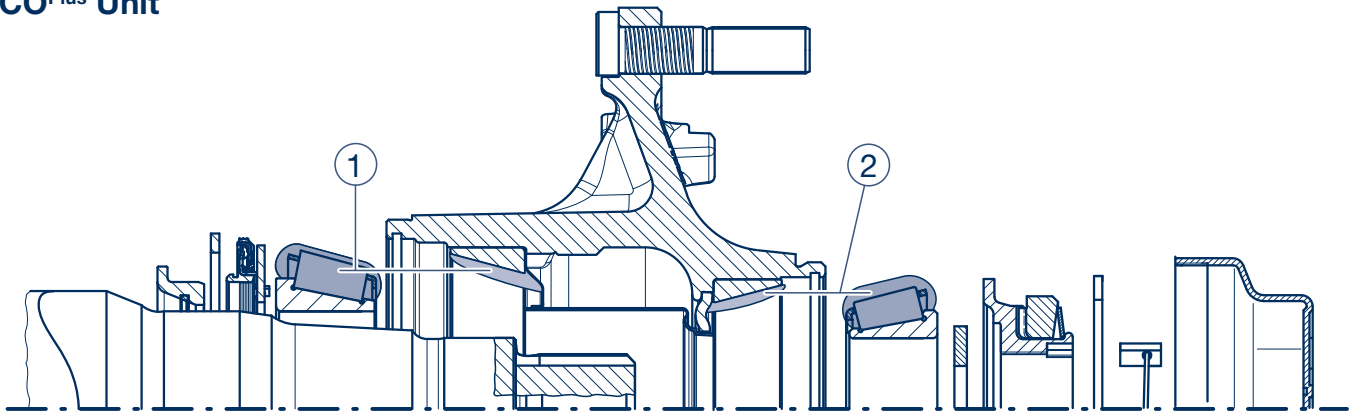

Maintenance work

**1 Check wheelnuts for tightness**

- the tightening torque of the wheel nuts must be checked after the first high load journey as well as after each wheel change and, if appropriate, retightened to the prescribed value –

Tighten wheel nuts diagonally using a torque wrench to the tightening torque shown in the table.

Wheel contact surfaces should not have additional coats of paint (risk of the wheels becoming detached!)

**Tightening torques for wheel nuts**

 It is imperative that the prescribed tightening torques are adhered to in order to ensure the wheels are securely fastened!

Stud alignment	Tightening torque
M 22 x 1.5	<b>510 Nm</b> (485 - 535 Nm)

Wheel centre alignment	Tightening torque
M 22 x 1.5	<b>630 Nm</b> (600 - 660 Nm)

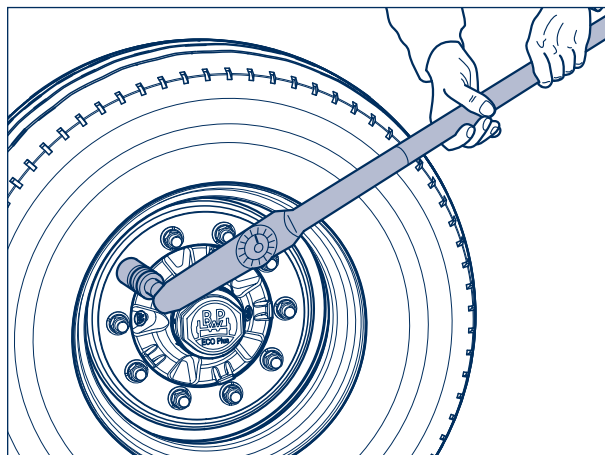

**Check the tyres for uneven wear, adjust the inflation pressure if necessary according to the manufacturer's specifications.**

- quarterly –

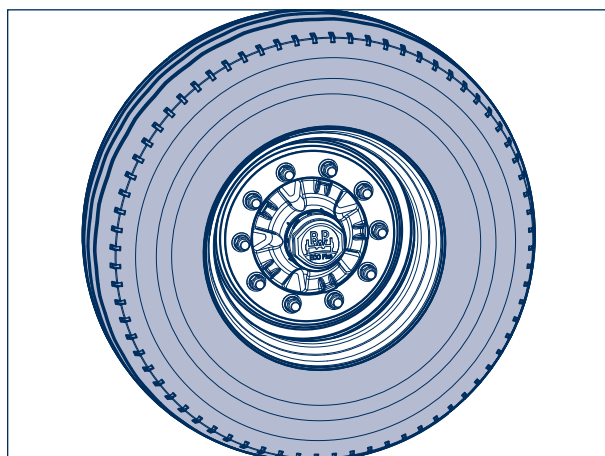

## 7 Lubrication and maintenance work

### 2 Check brake lining thickness – quarterly –

Open inspection hole by folding back the rubber flap.

The brake lining should be replaced at a residual lining thickness of 5 mm (check with feeler gauge) or on reaching the bottom of the indicator machined into the edge of the lining.

Re-insert the rubber flap, if necessary.

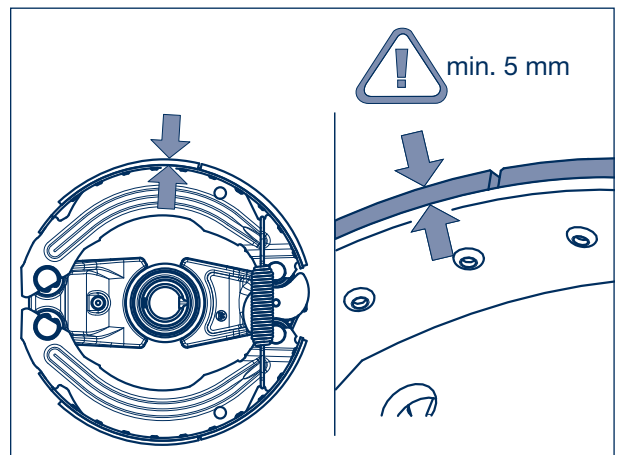
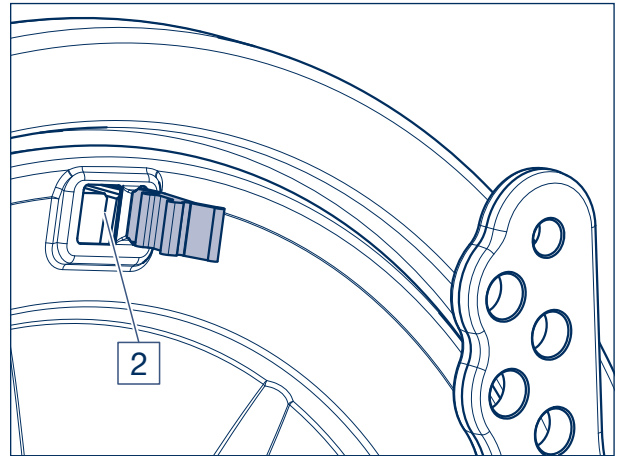

### 3 Check the brake drum for cracks and check the internal diameter – quarterly –

Check the condition of the brake drum and ensure there is adequate remaining thickness. If the wear is approaching the wear edge, measure the brake drum and renew it if the maximum permitted amount of wear has been reached.

Max. amounts of wear, measured at the position with the greatest wear:

Brake	Brake shoe width (mm)	Ø Max. amount of wear (mm)	Ø Max. skimming size (mm)
SN 420	180	425.5	424

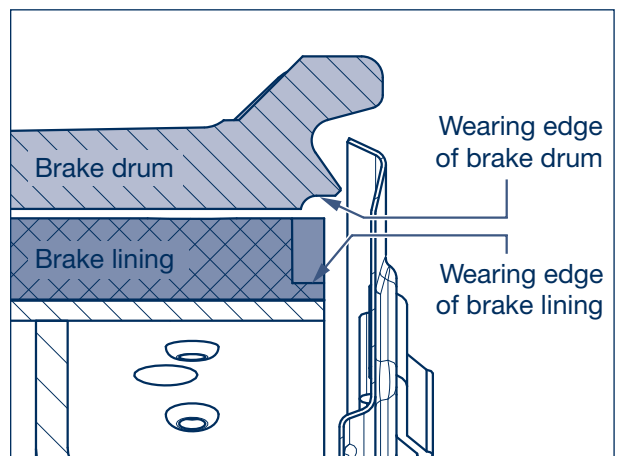

○ **Visual inspection**

- every 6 months -
- quarterly in use outside Europe -

Check all components and welding seams for damage and wear.

4 **Check operation of the automatic slack adjuster ECO-Master**

- every 6 months -
- quarterly in use outside Europe (e.g. within the scope of the statutory checks) -

**Prevent the vehicle from rolling away.**

**Release the service brakes and the handbrake.**

Free play check:

Operate the slack adjuster by hand or with 0.8 bar. Check that the idle stroke "a" corresponds to 10 - 15 % of the connected brake lever length "B", e.g. brake lever length 150 mm = idle stroke 15 - 22 mm.

Check the adjustment if the idle stroke is not within tolerance:

Remove rubber seal cap.

Turn back adjustment screw by approx. 3/4 of a turn in a counterclockwise direction using a ring spanner. Free play of at least 50 mm with a lever length of 150 mm must be available.

Actuate the brake lever several times by hand. When this is done automatic adjustment must take place smoothly. Engagement of the clutch coupling is audible and on the return stroke the adjustment screw turns slightly in a clockwise direction.

Grease with **ECO-Li<sup>Plus</sup>**, see also ② on page 16.

Adjust the brake, see page 47.

**Fit seal cap.**

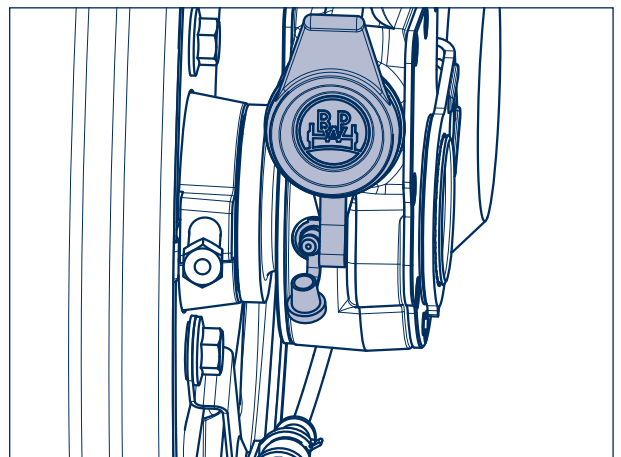
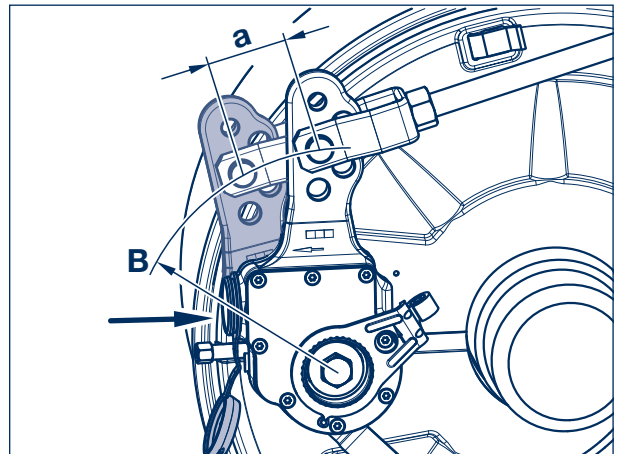

## 7 Lubrication and maintenance work

- 5 **Check wheel hub bearing play**  
– at every brake lining replacement, latest annually –

**Prevent the vehicle from moving away.  
Release the service and parking brakes.**

In order to check the wheel hub bearing play lift the axle until the wheels are off the ground. Release the brake. Apply a lever between the tyre and the ground and check the play.

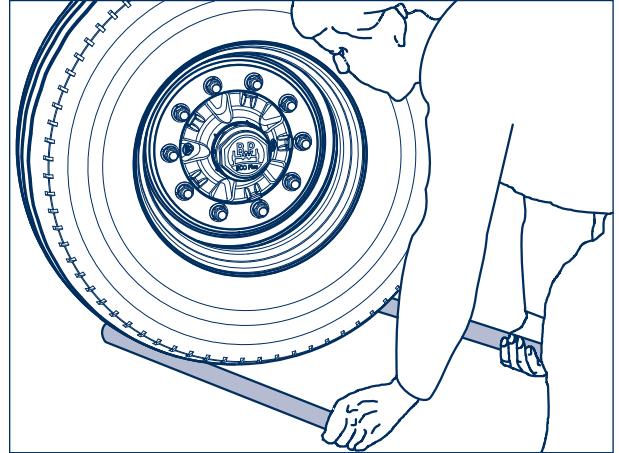

If bearing play is detected on **ECO<sup>Plus</sup> Unit**:

Adjust the bearing play:

1. Unscrew the hubcap.
2. Remove the hooked spring ring with a wedge from the axle nut.
3. Fasten axle nut using a hexagon socket spanner (BPW no. 05.364.26.05.0) whilst rotating the ECO Unit. It should take several turns until the clutch on the axle nut slips.



**Important!**  
**Do not use an impact driver.**

4. Fit the retaining key in the groove between the axle stub and the nut (do not reset the axle nut).
5. Insert the hooked spring ring behind the edge of the axle nut.
6. Tighten the hubcap to 800 Nm.

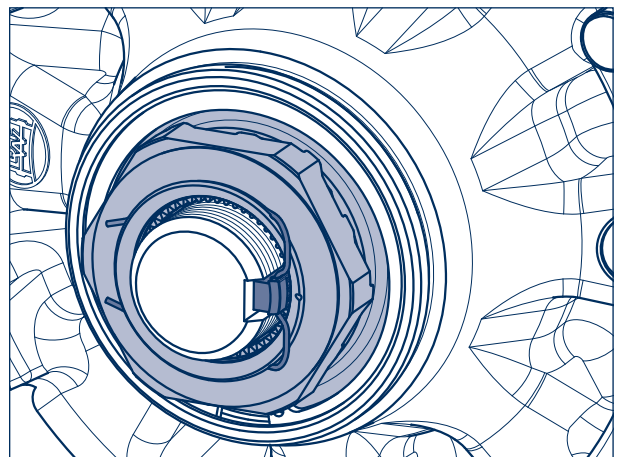
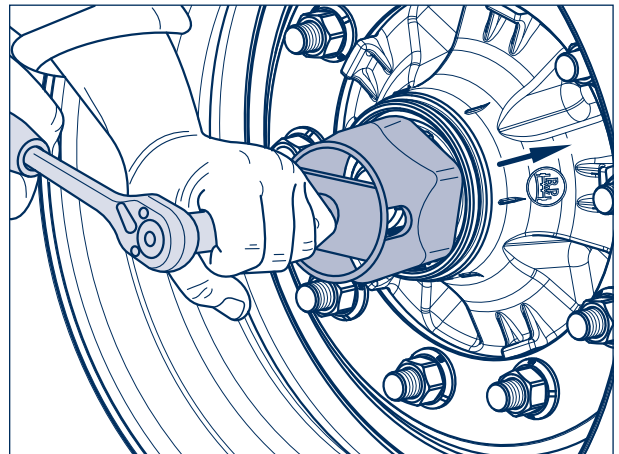

# Changing the brake lining 8

To check the brake lining thickness, open the inspection hole by pulling the rubber flap (520).

If the remaining thickness of the lining is 5 mm or less (or when the bottom edge of the wear pocket on the brake lining is reached), the brake lining must be renewed.

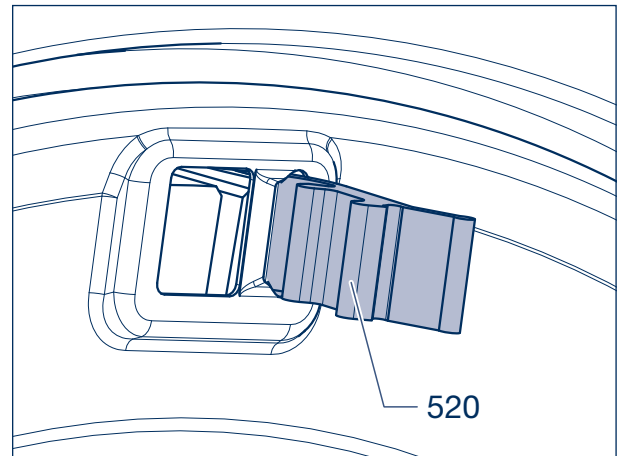

Picture 1

## 8.1 Removal of the wheel hub / brake drum unit

 During dismantling / assembling the wheel can remain mounted on the wheel hub.

We recommend removing the wheel to facilitate handling of the hub/drum unit when changing the bearing.

- [1] Prevent the vehicle from rolling away and release the brakes.
- [2] Unscrew the cap (460) from the wheel hub.
- [3] Support the vehicle in such a way that an accident cannot occur. Raise the axle until the tyres are free.
- [4] Remove the hooked spring ring (448) and retaining key (447) from the axle nut (446).

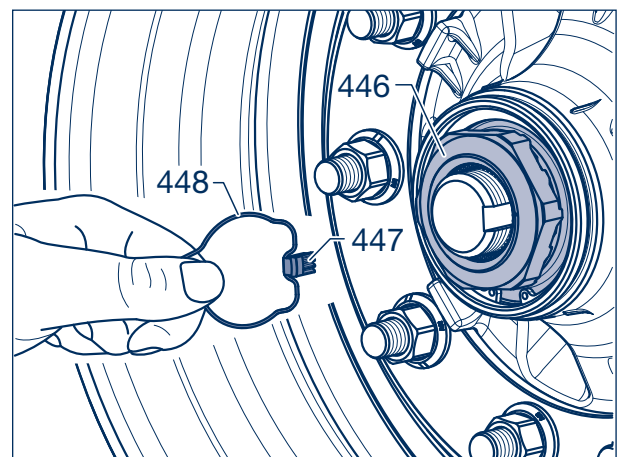

Picture 2

- [5] Unscrew the axle nut (446).

 Unscrew the axle nut to withdraw the complete wheel, hub, drum, bearing and seal arrangement from the stub axle.

- [6] Remove the complete hub bearing unit sideways from the axle (wheel mounting trolley).

The brake is now accessible.

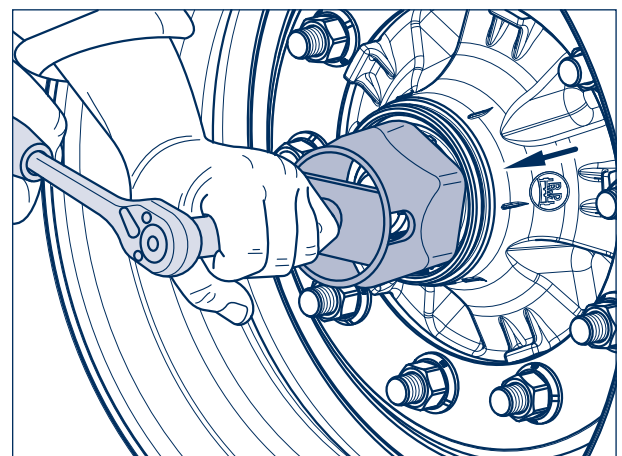

Picture 3

## 8 Changing the brake lining

### 8.2 Changing the brake lining

- [7] Remove rubber seal cap from the slack adjuster (280).
- [8] Turn back adjustment screw (arrow) in a counter-clockwise direction using a ring spanner.
- [9] Reset slack adjuster (280) until the S-cam of the brake cam shaft (240, 241) reaches the zero position.
  
- [10] Lever the positioning springs (367, 368) apart using a screwdriver.

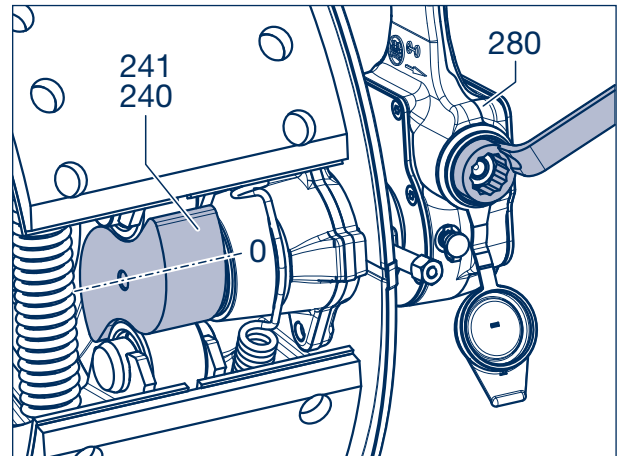

Picture 4

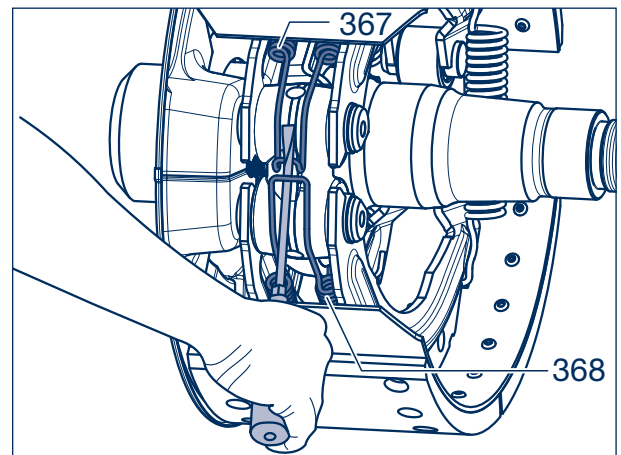

Picture 5

- [11] Place assembly lever on axle beam and lift brake shoes (330).



**Repair guide!**

**When lifting, protect the sensor (570) and the sensor cable from damage.**

Remove brake shoes.

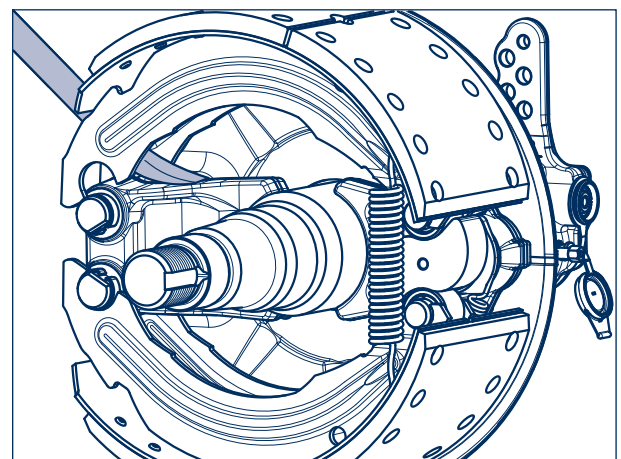

Picture 6



- [12] Remove return springs (363, 365) from the brake shoes.

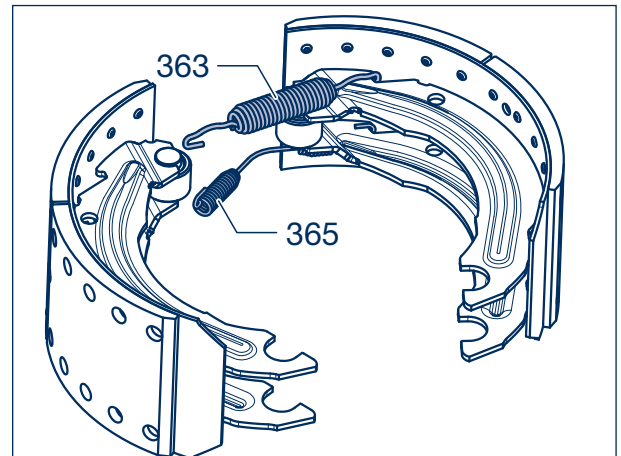

Picture 7

- [13] Remove the positioning springs (367, 368 / arrow) from the brake shoes (330).

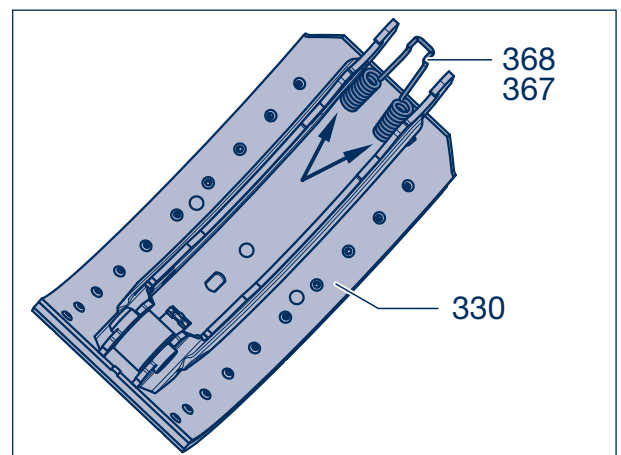

Picture 8

- [14] Remove the old brake lining and clean the brake shoe. The surface must be free of rust and be smooth.



**Repair guide!**

The rivets (357) should always be pressed out using a riveting machine, preferably with hydraulic actuation. The equipment used must be suitable for the rivet diameter. Modern rivet punches can universally accept hollow and semi hollow rivets.

The use of unsuitable rivet punches may damage the brake shoe.

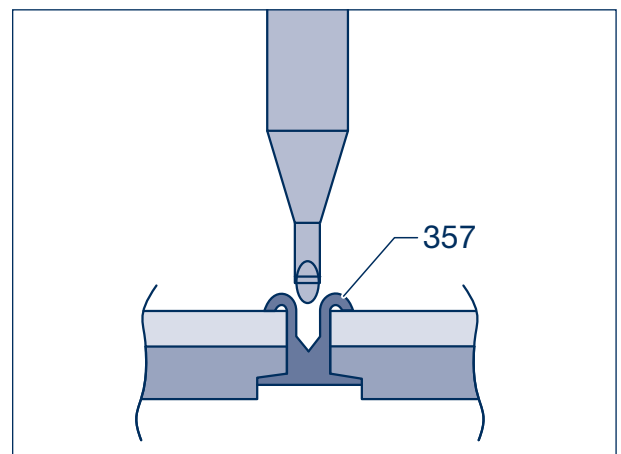

Picture 9

## 8 Changing the brake lining

If there is no riveting machine available:

Shear off the closed head of the rivet with a chisel (No. 1) or remove the closed head using 8.6 mm diameter drill bit. (No. 2). Drive out the rivet with a punch (No. 3).

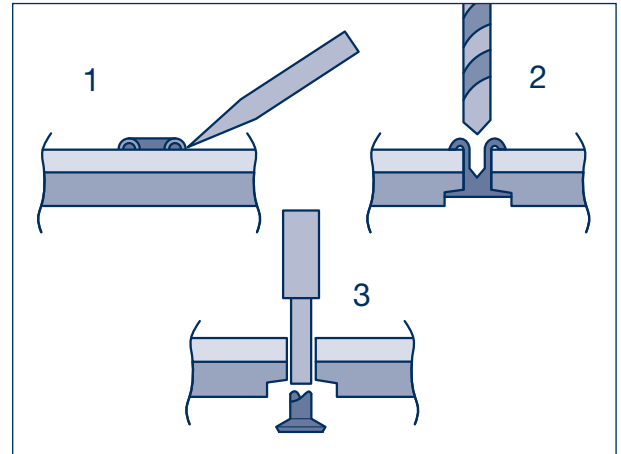

Picture 10

- [15] Check the diameter of the rivet hole using a rivet hole gauge. The diameter is not allowed to be more than 0.6 mm larger than the rivet diameter (DIN 7513).

### Frequent faults

- 1 Loose rivets indicate enlarged rivet holes
- 2 Rivet hole damaged during boring
- 3 Damaged platform edge
- 4 Worn shoe support
- 5 Deformed shoe web
- 6 Rivet hole deformed during boring
- 7 Rivet hole damaged by riveting machine
- 8 Corroded platform area
- 9 Damaged shoe web end
- 10 Worn shoe roller bearings
- 11 Cracked welding seam
- 12 Damaged platform surface
- 13 Corroded welding seam
- 14 Deformed platform surface

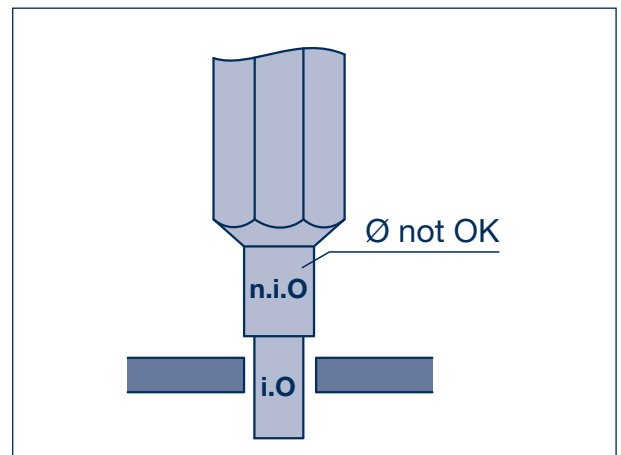

Picture 11

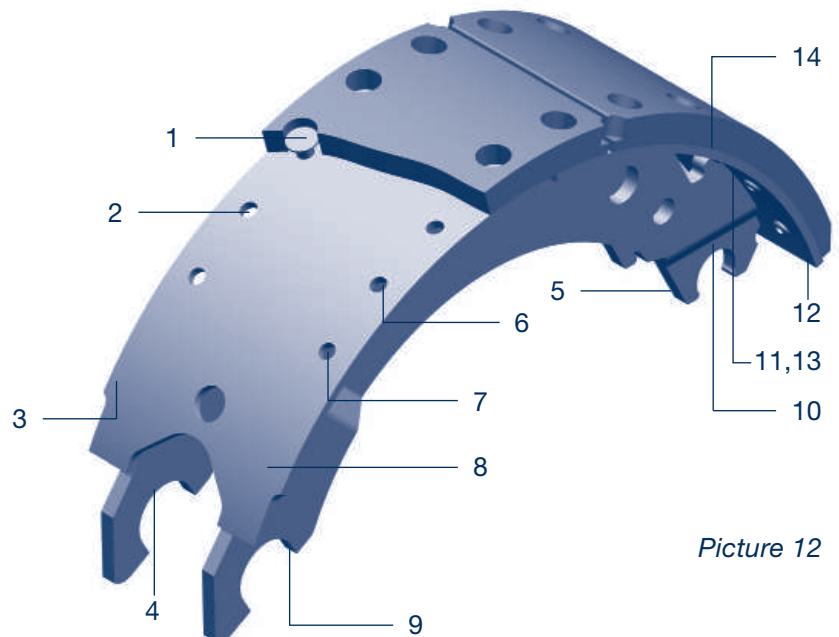

Picture 12



### Repair guide!

With skimmed brake drums use corresponding oversize brake linings.

The brake shoe must snugly fit on the platform, i.e. the platform must not be concave. The shoes must be carefully cleaned, e.g. by sandblasting by means of a shoe grinding unit.

- [16] Insert all rivets (357) and hold in position by crimping edges. Rivet brake lining (350) into place taking care to follow the correct riveting order (picture 14).

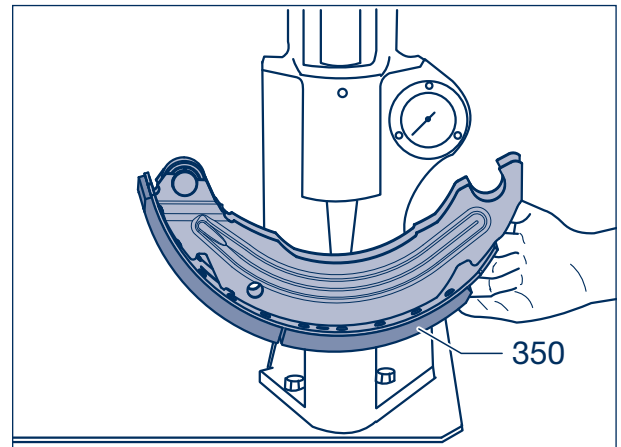

Picture 13

-  Rivet as shown from the inside out.

Riveting force: **21000 N** (20000 - 22000 N)

Rivets: Semi-tubular rivets, galvanized steel  
8 x 15 mm meeting DIN 7338 B

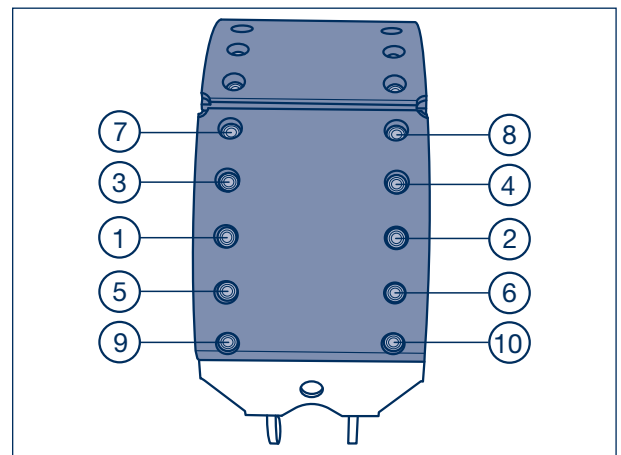

Picture 14

## 8.3 Riveting check

Picture 15, Pos. 1:  
Rivet length correct, the hole inner wall and strength are correct.

Picture 15, Pos. 2:  
Rivet too short, no inner hole recess and poor closing head formation.

Picture 15, Pos. 3:  
Rivet too long, inadequate closing head, crack formation.

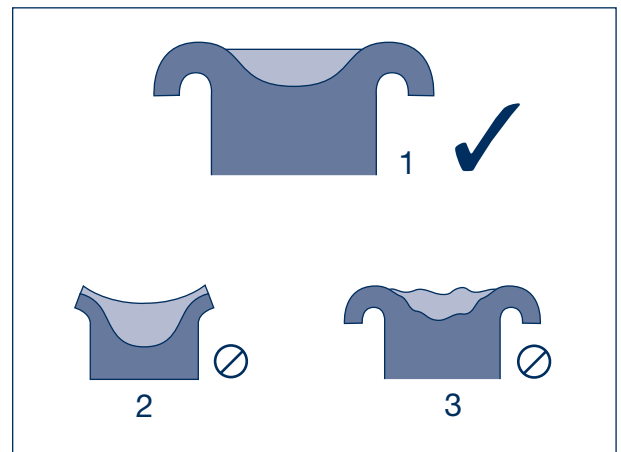

Picture 15

## 8 Changing the brake lining

- ☞ A light tap with a hammer will determine whether the riveting is satisfactory or not. A dull thud indicates a loose lining. A high-pitched response indicates that the riveting is correct.
- ☞ A feeler gauge can be used to check for cavities under the lining. A cavity of more than 0.15 mm beyond the first row of rivet holes can lead to noise problems.
- ☞ Finally, the linings should be checked for cracks in the area of the rivets which would indicate incorrect riveting.

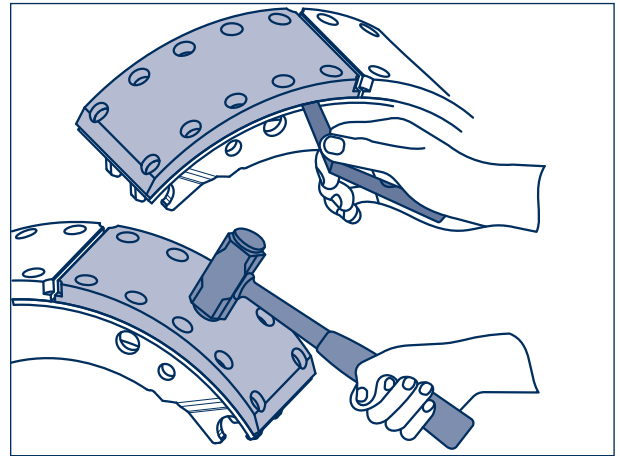

Picture 16

### ☞ Health and safety precautions

Brake dust contains large volumes of breathable fine dust and is hazardous to your health, even in case of non-asbestos material. Safety regulations prescribe extraction systems with a suction power between 40 and 50 m<sup>3</sup>/h.

Wheel brakes must never be cleaned down using compressed air or cleaned using a dry brush.

It is strongly recommended to use clean water without chemical additives or a special vacuum cleaner machine to clean down the brakes. The use of detergents might impair the braking effect.

### 8.4 Brake shoe installation

- [17] Check roller (345) for wear, renew as appropriate. Remove bearing bolts (346).



**Repair guide!**  
In the event of wear, exchange roller bearing bolts and rings.

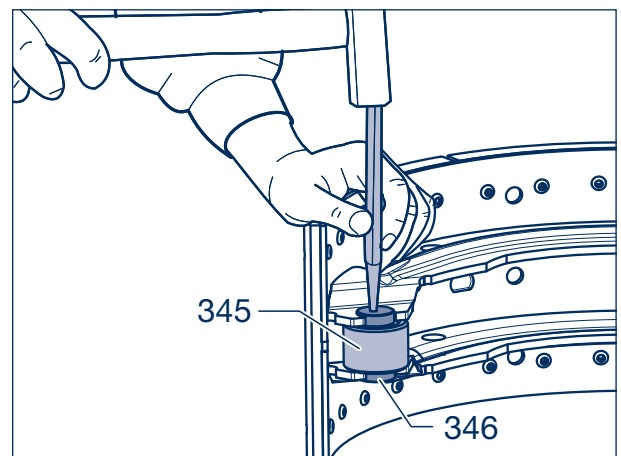

Picture 17

- [18] Clean bearing bush and apply BPW special longlife grease ECO-Li<sup>Plus</sup> (4 g).
- [19] Insert new roller (345) with rings (348) into the brake shoe webs.

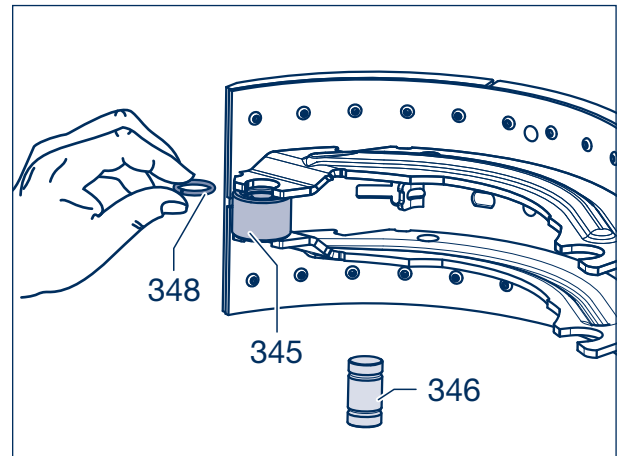

Picture 18

- [20] Drive in bearing bolt (346) until both rings (348) snap into the annular grooves of the bearing bolt.

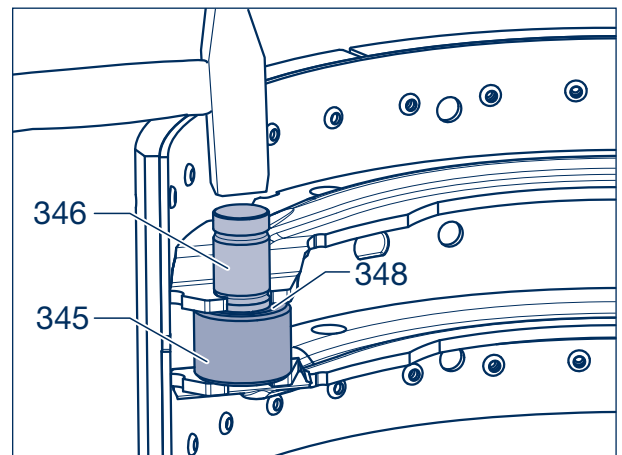

Picture 19



**Repair guide!**  
Insert new return springs every time the brake linings are changed.

- [21] Insert the return springs (363, 365) into the brake shoes (330).

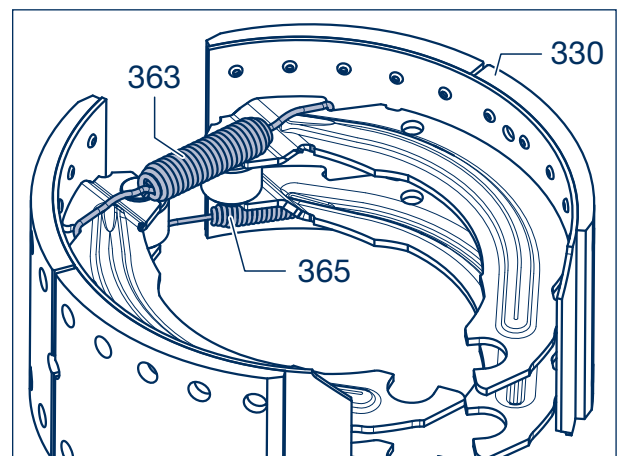

Picture 20

## 8 Changing the brake lining

- [22] Hook the positioning springs (367, 368 / arrow) into the brake shoes (330).

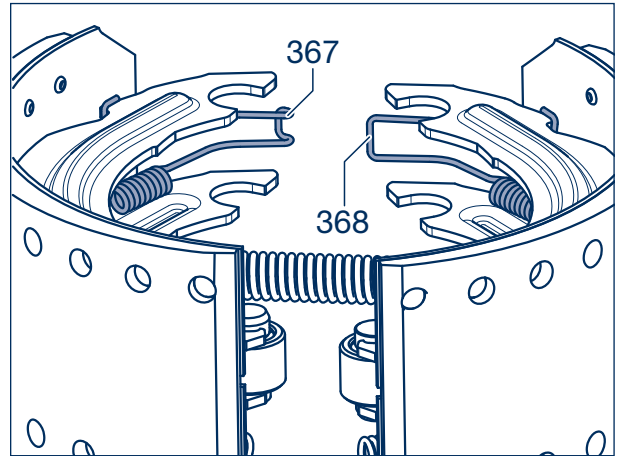

Picture 21

 Only for models with ABS/ABV

- [23] Check sensor (570) for damage and displacement (displacement force 100 - 200 N). If necessary, smear clamping bush (571) and sensor with special silicone grease (replace clamping bush). Before fitting hubs, always press clamping bush and sensor up to endstop. When fitting the hub, the sensor will be pushed back into the correct position by the exciter ring (560).

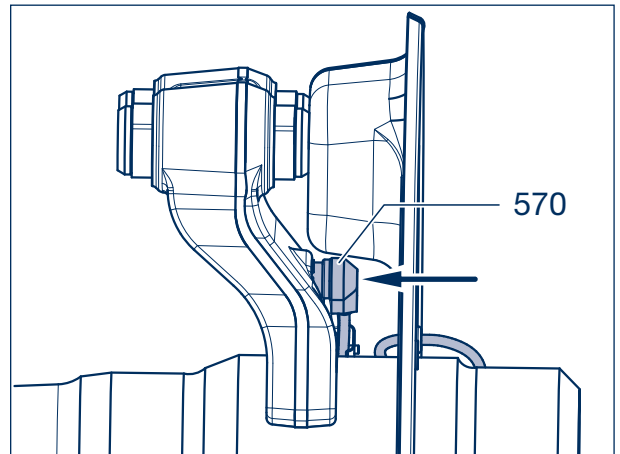

Picture 22

### 8.5 Installation of the brake shoes

- [24] Check hooked spring rings (325) on the brake anchor plate for wear and seating. If necessary, change components.



**Repair guide!**  
Hooked spring rings must be renewed when the brake lining is changed, if not before.

- [25] Smear BPW special longlife grease **ECO-Li<sup>Plus</sup>** onto bearing points (arrows) of brake shoes.

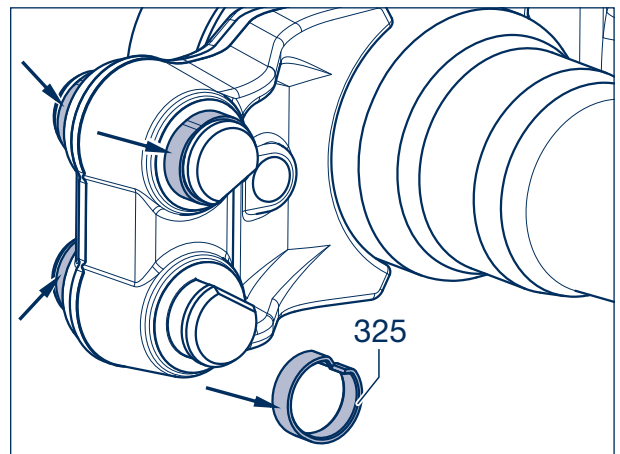

Picture 23

- [26] Place upper brake shoe (330) with the roller (345) on to the S-cam.
- [27] Fix brake shoe on to the spring ring (325) by hitting lightly with a soft hammer.

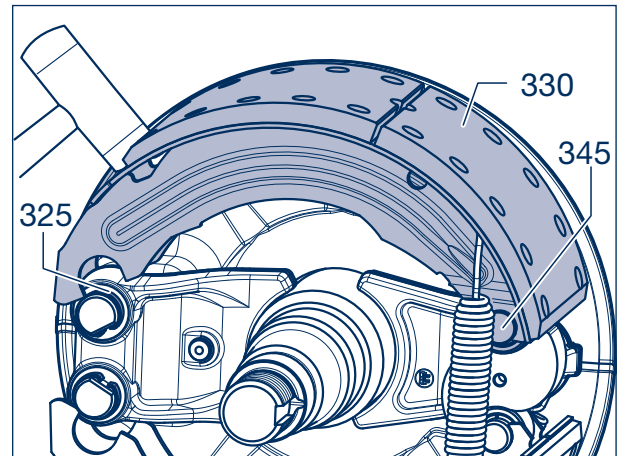

Picture 24

- [28] Assemble lower brake shoe (330) and fix on to the spring ring (325) by hitting lightly with a soft hammer.

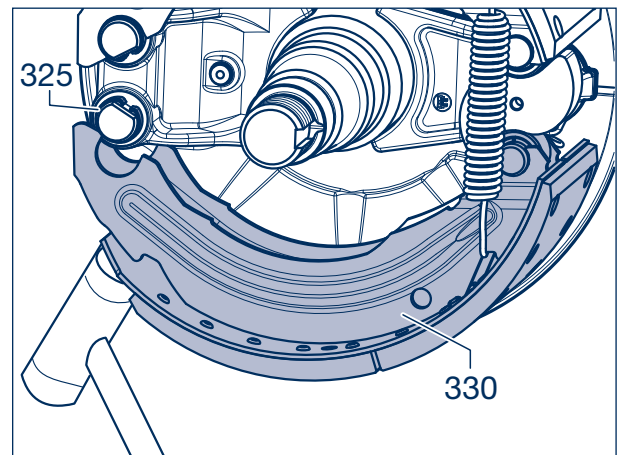

Picture 25

- [29] Link the positioning springs (367, 368) using a screwdriver.

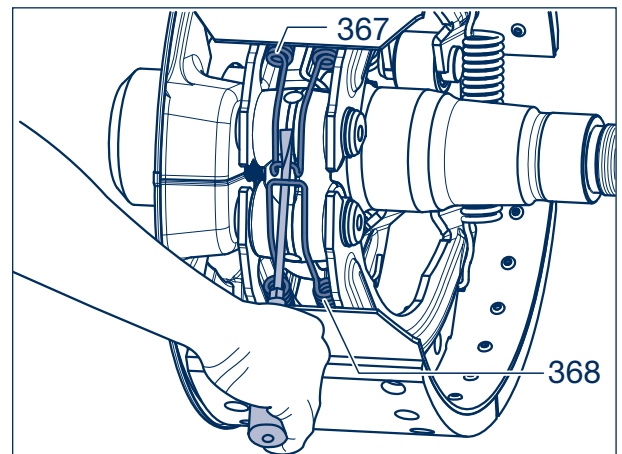

Picture 26

## 8 Changing the brake lining

[30] Expand brake to small extent.

[31] Using a brake lathe turn down the brake linings to fit the brake drum diameter until an even wear surface has been obtained.



### **Repair guide!**

**There is no need to machine the brake linings when fitting genuine BPW replacement lined brake shoe assemblies.**

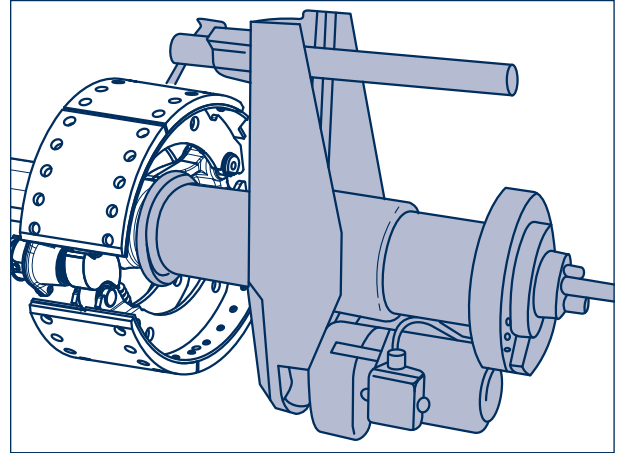

Picture 27

[32] Check the condition of the brake drum and ensure there is adequate thickness remaining. If the wear is approaching the wear edge, measure the brake drum and renew it if the maximum permitted amount of wear has been reached.

Max. amounts of wear, measured at the position with the greatest wear:

Ø max. amount of wear:	425,5 mm
Ø max. skimming size:	424 mm

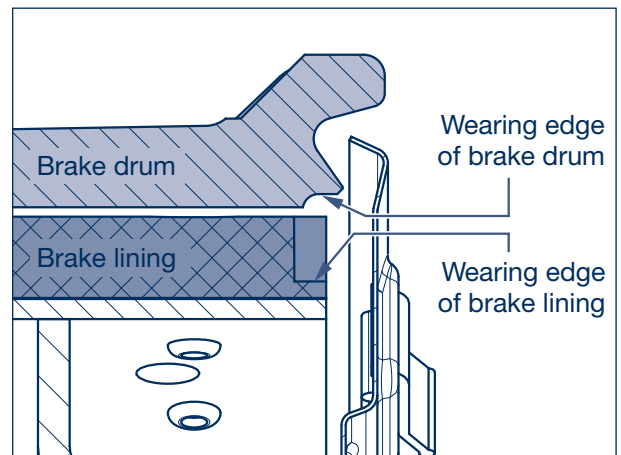

Picture 28

### 8.6 Installation of the wheel hub brake drum unit

[33] Thoroughly clean the bearing journals of the axle stub with a microfibre cloth. The journals must be bright, dry and free from grease.

Apply **Castrol White T** using a fine bristled brush evenly and thinly to the bearing journals. Ensure that the bearing journal is completely coated. Castrol White T must not be diluted.

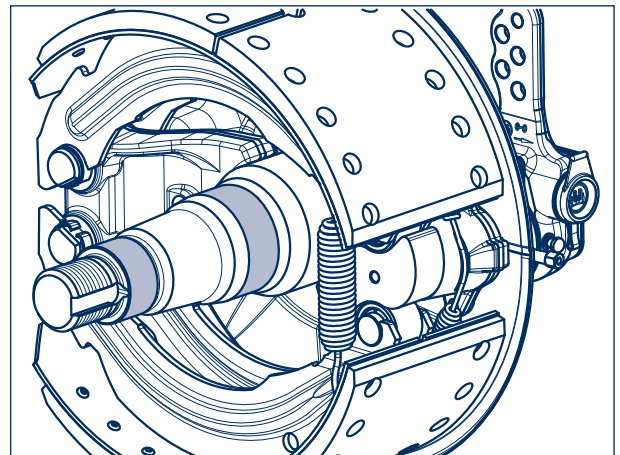

Picture 29



- [34] Align the tab of the washer (445, arrow) to the groove of the stub axle by turning the axle nut (446) and gently press the wheel hub unit.
- [35] Push the complete hub unit centrally onto the stub axle.
- [36] Screw on the axle nut; in this way the complete hub unit is mounted onto the stub axle.

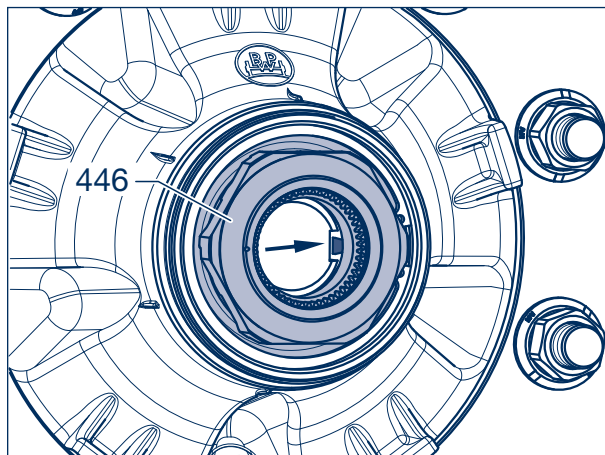

Picture 30

- [37] Fasten axle nut using a hexagon socket spanner whilst rotating the ECO hub unit. It should take several turns until the clutch on the axle nut slips (do not use an impact driver).

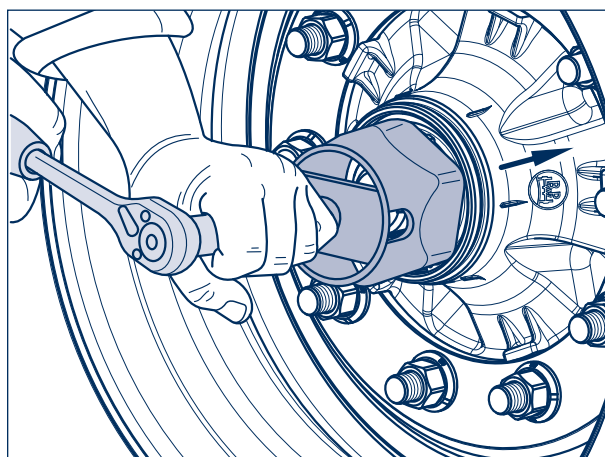

Picture 31

- [38] Fit the retaining key (447) in the groove between the axle stub and the nut (446) (do not reset the axle nut).
- [39] Insert the hooked spring ring (448) behind the edge of the axle nut.

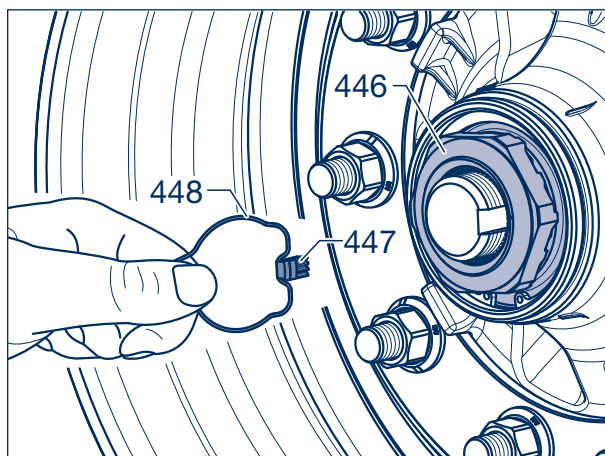

Picture 32

## 8 Changing the brake lining

[40] Smear the threads of the hub cap (460) all round with BPW special longlife grease ECO-Li<sup>Plus</sup>.

[41] Screw hub cap onto the wheel hub (435) and tighten to the tightening torque of 800 Nm.

 **Adjust brake.**  
**Adjust the automatic slack adjuster ECO-Master as described on page 47, respectively.**

 **Important!**  
**New brake linings only have maximum effect after a few braking actions.**

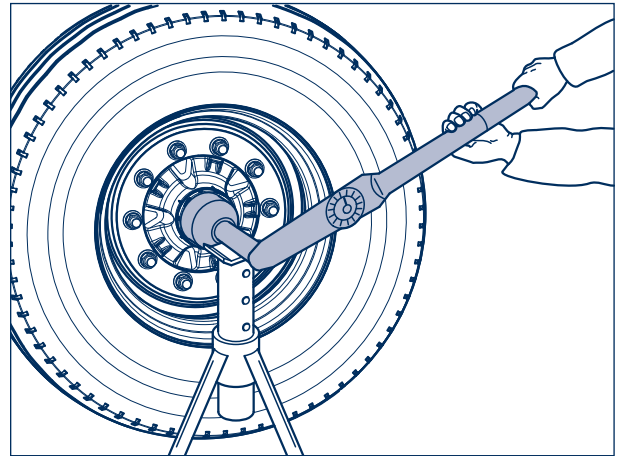

Picture 33

# Dismantling and assembling the hub unit

9

- [1] Dismantling and refitting the complete wheel hub bearing, see chapter 8.
- [2] To remove the outer roller bearing (441), remove circlip (438) and axle nut (446) from the wheel hub (435).

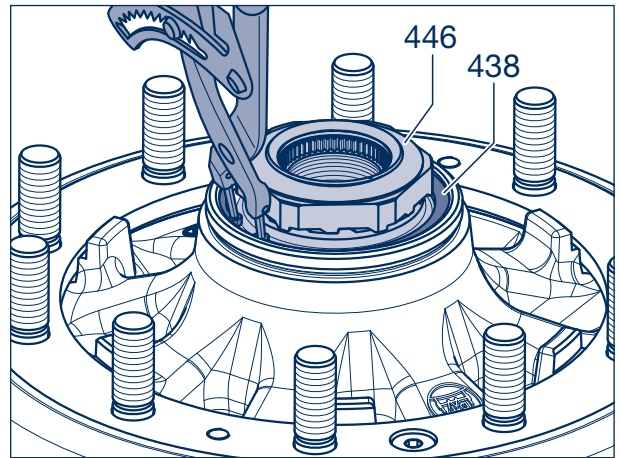

Picture 1

- [3] Remove lug washer (445) and roller bearing (441).



**Repair guide!**

Mark both the hub and bearing to ensure correct positioning during re-assembly.

It is essential for the bearing inner races and rollers to be re-inserted in the same hubs.

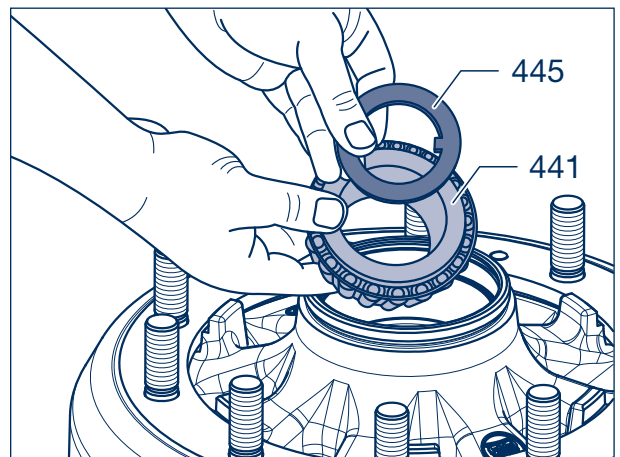

Picture 2

- [4] To remove the inner roller bearing (430), remove circlip (437) from the wheel hub (435).

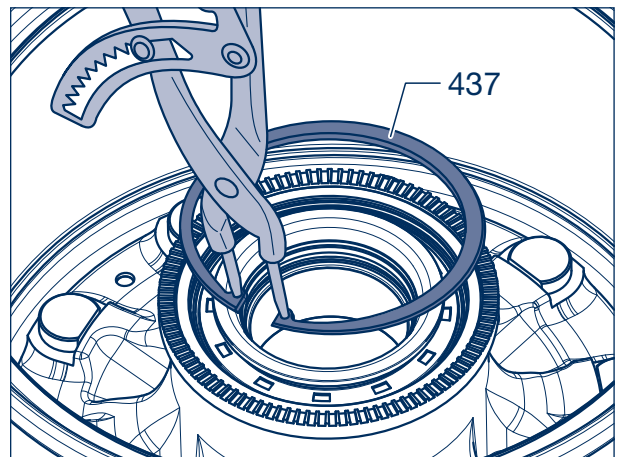

Picture 3

## 9 Dismantling and assembling the hub unit

- [5] Remove thrust ring (421) with O-Ring (424) and grease seal (422).

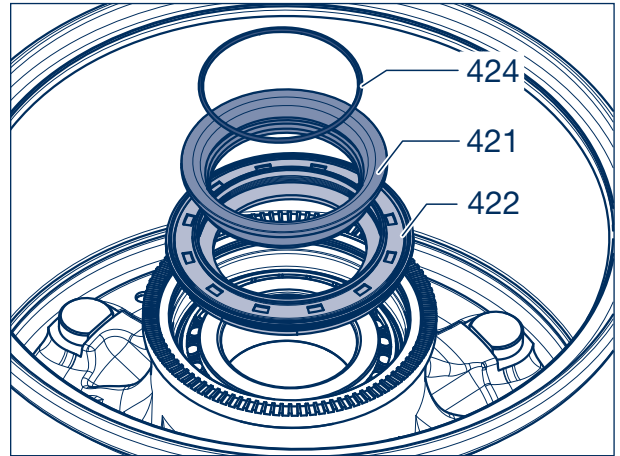

Picture 4

- [6] Remove the inner tapered roller bearing (430) and then the seal (432, bearing intermediate seal).
- [7] Remove both tapered roller bearings (430, 441), clean thoroughly and check for wear. Renew if necessary.

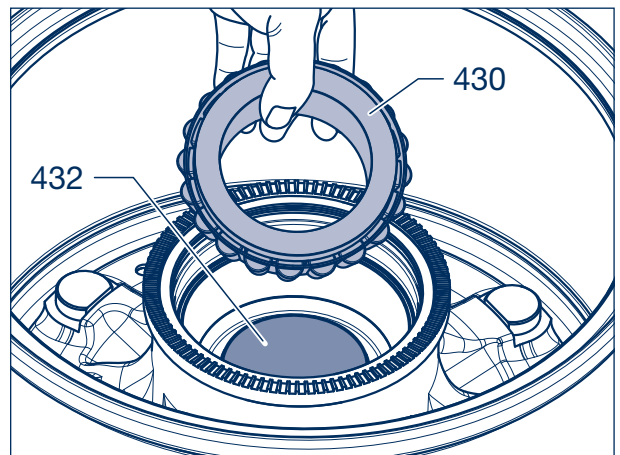

Picture 5



**Note:**

We recommend removing the brake drum (380) if it is necessary to renew the bearing cups.

- [8] Remove both countersunk screws (390, M 12 x 25, SW 8) from the brake drum.
- [9] Drive the wheel studs (472) out of the removed hub/brake drum unit (do not damage the threads of the wheel studs).



**Caution!**

**RISK OF INJURY!**

The wheel hub drops into the brake drum when the wheel studs are knocked out.

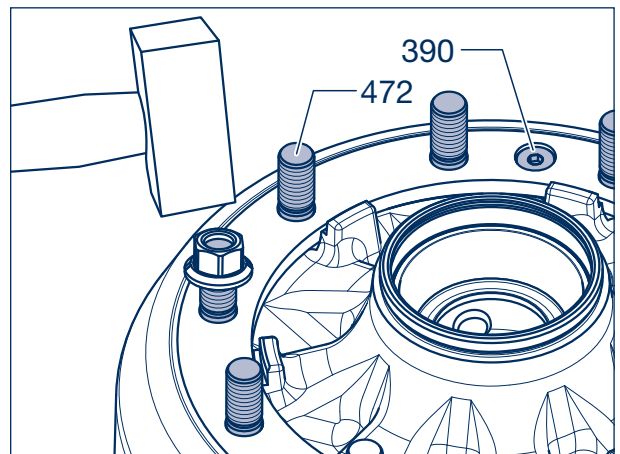

Picture 6

### Removing the bearing cups

- [10] Drive the bearing outer races including thrust washer (440) out of the wheel hub (435).
- [11] Remove the dust cover (431) from the wheel hub.

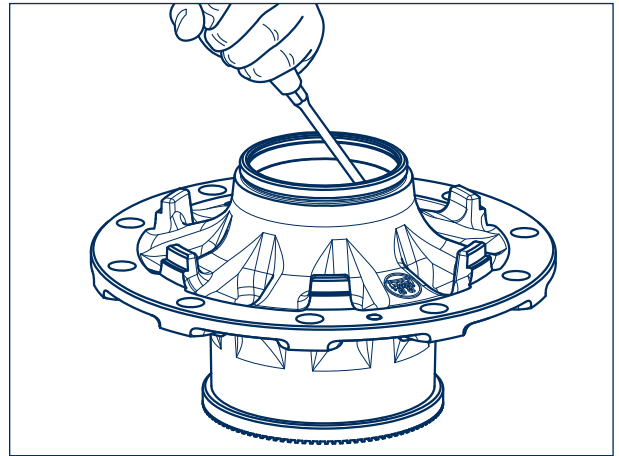

Picture 7

- [12] Fit the thrust washer (440) with the curved side facing the hub (435).

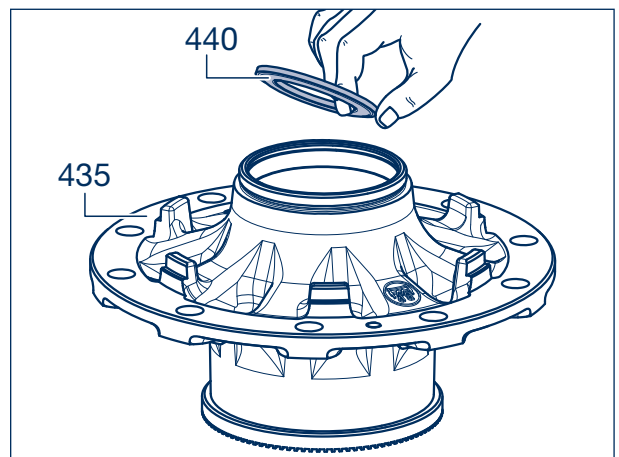

Picture 8

- [13] Insert the new dust cover (431) with the curved side facing the hub (435).

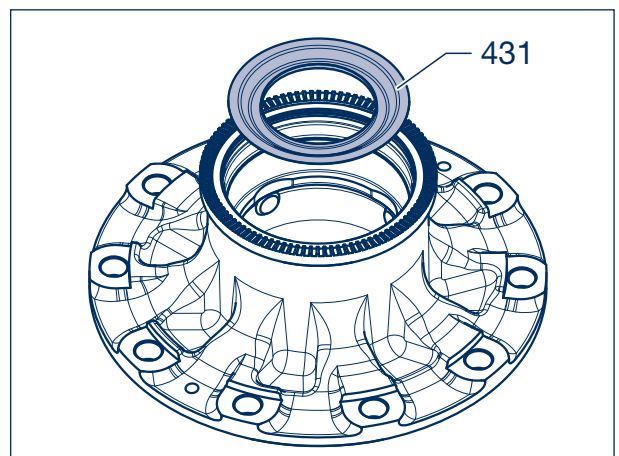

Picture 9

## 9 Dismantling and assembling the hub unit

### Installing the bearing cups

- [14] Centre the bearing outer races and insert them in the wheel hub. Install using a press (min. 6 t) and the BPW insertion tools 15.011.20052 and 15.013.20052.



**Repair guide!**  
Make sure the bearing cups are correctly seated in the wheel hub.

- [15] Insert the seal (432, bearing intermediate seal) between the installed bearing outer races.

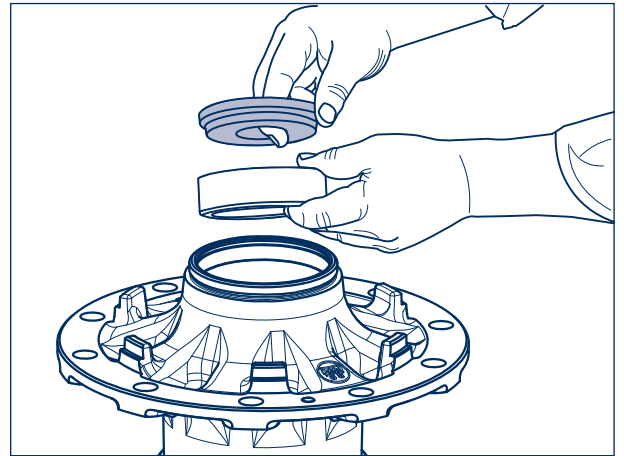

Picture 10



**Repair guide!**  
A corrosion inhibitor may be needed to guide prior to fitting the brake drum.

- [16] Place the wheel hub (435) into the brake drum (380). Ensure that the contact surfaces are clean.
- [17] Use two countersinking screws (390, M 12 x 25, SW 8) to secure the wheel hub on the brake drum. Tightening torque: 66 Nm

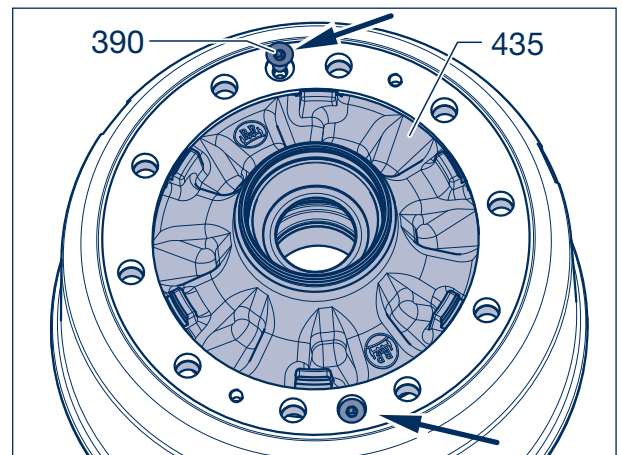

Picture 11



**Repair guide!**  
Inspect the wheel studs (472) for serviceability and fit new wheel studs, if necessary.

- [18] Insert the wheel studs (472) as far as possible into the hub, paying attention to the anti-rotation lock in the wheel hub (arrow).
- [19] Knock in the wheel studs as far as the stop. The flattened side of the wheel stud head must be in contact with the wheel hub collar.

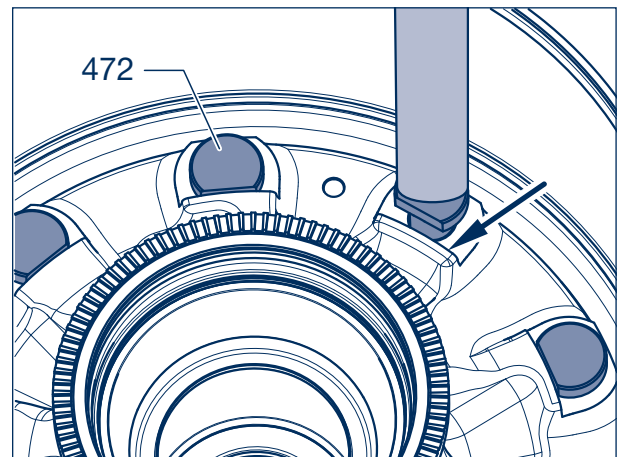

Picture 12

[20] Grease both tapered roller bearings (430, 441) with BPW special longlife grease ECO-Li<sup>Plus</sup>.



**Note:**  
We recommend greasing the bearings with BPW grease applicators 99.00.000.9.55.

**BPW special longlife grease ECO-Li<sup>Plus</sup>**

Grease quantity per taper roller bearing

	① inner bearing	② outer bearing
Manual greasing	170 g	120 g
Greasing with a grease applicator	130 g	90 g

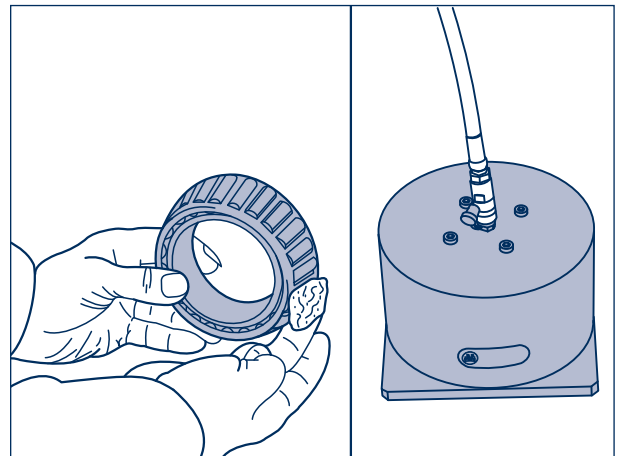

Picture 13

[21] Fit inner roller bearing (430) into wheel hub (435).



**Repair guide!**  
Do not mix up bearing races and outer bearing rings.

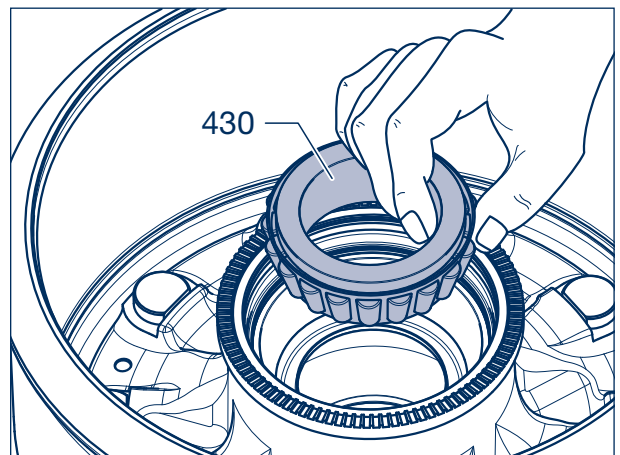

Picture 14

[22] Insert the new O-ring (424) into the groove of the thrust washer (421).

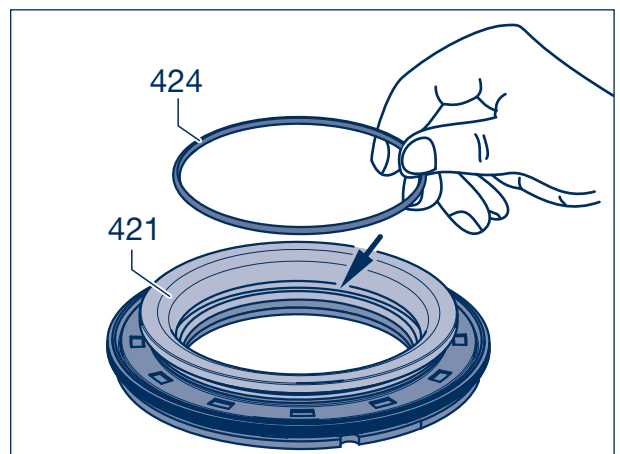

Picture 15

## 9 Dismantling and assembling the hub unit

- [23] Insert the thrust washer (421) with oil seal (422) and O-ring (424) into the wheel hub (435).

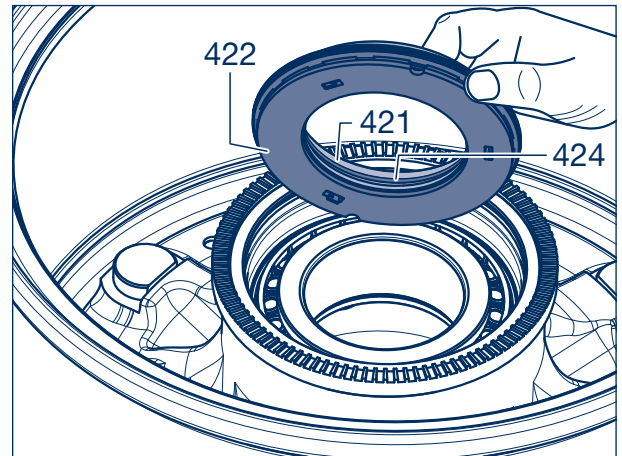

Picture 16

- [24] Place the hub cap (460) onto the seal (422) and knock it in with light hammer blows until the seal is in contact with the bearing (430).

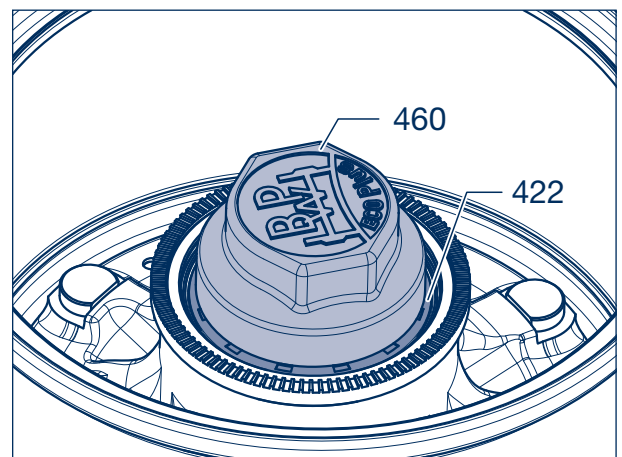

Picture 17

- [25] Fit circlip (437) into the groove of the wheel hub (435).

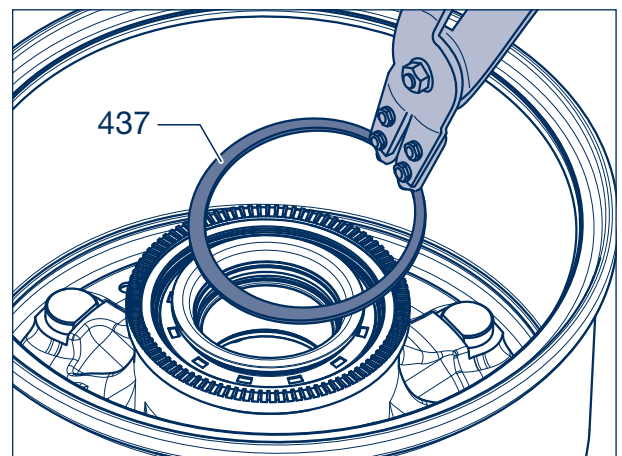

Picture 18



[26] Fit outer roller bearing (441) into wheel hub (435).

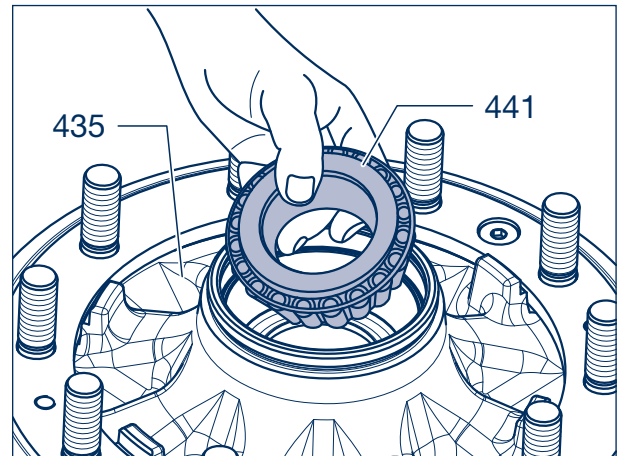

Picture 19

[27] Place the keyed (445) thrust washer (with the embossed BPW) next to the tapered roller bearing (441).

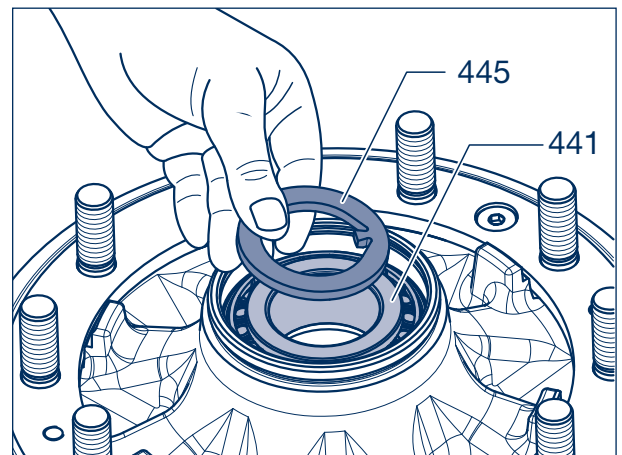

Picture 20

[28] Fit circlip (438) with axle nut (446) into the groove of the wheel hub.  
Mounting the complete wheel hub, see pages 32 to 34.

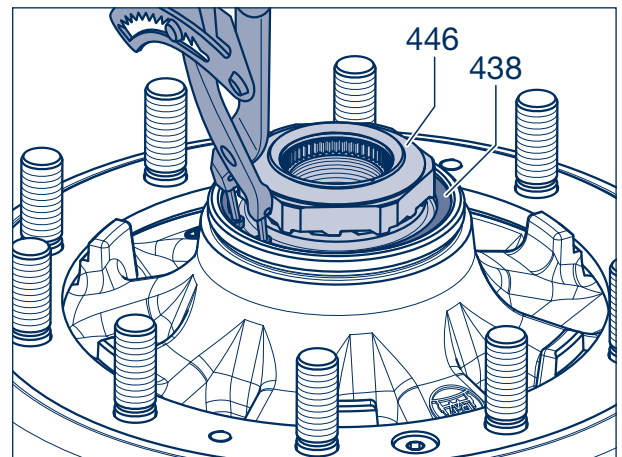

Picture 21

## 10 ABS / ABV

- [1] Check sensor (570) for damage and displacement (displacement force 100 - 200 N).
- [2] Lubricate clamping bush (571) and sensor with special silicone grease (replace clamping bush). Before fitting hubs, always press clamping bush and sensor up to endstop.

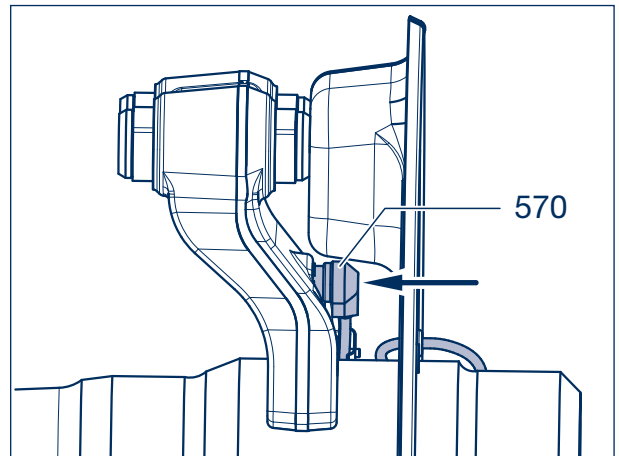

Picture 1

- [3] To change a damaged exciter ring (560) heat the exciter ring with a torch and extract.
- [4] Heat the replacement exciter ring from 80° to max. 120°C and press into place, ensuring the seat is clean and undamaged.

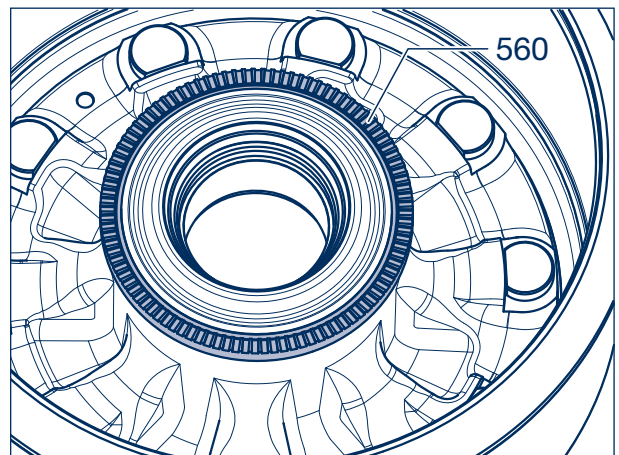

Picture 2

# Brake camshaft 11

☞ Remove the wheel/hub unit and brake shoes, see sections 8.1 and 8.2.

- [1] Remove screw (267, SW 19) from the brake camshaft (240, 241).
- [2] Remove slack adjuster (280) with disc (263).

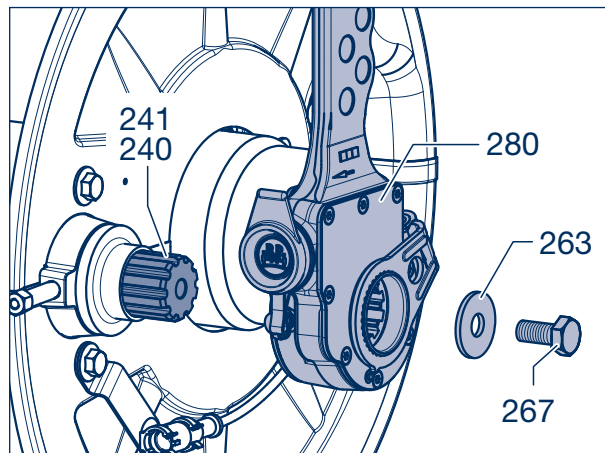

Picture 1

- [3] Pull sleeve from the brake camshaft (260).
- [4] Take brake camshaft (240, 241) out of the brake anchor plate.



**Repair guide!**  
**Mark the wheel station position of the brake camshaft.**  
**It is imperative that the brake camshafts are re-used in the same location.**

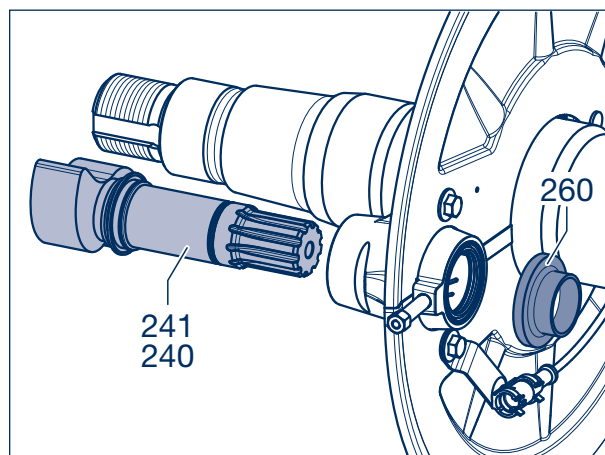

Picture 2

- [5] Lever the shaft seal (258) from the housing.

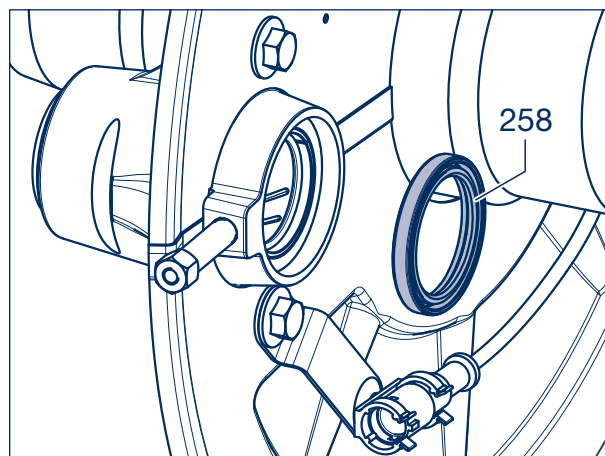

Picture 3

# 11 Brake camshaft

- [6] Check bush (210) in brake anchor plate and, if necessary, change bush (max. bearing play 0.8 mm).
- [7] Drive in new bush with mandrel (BPW no. 05.001.04.04.0), with the ring groove (arrowed) pointing towards the grease nipple.
- [8] On the outside, the bush must stand back  $7.2 + 0.5$  mm. Only apply light strokes when driving in and out; apply counter-pressure to brake anchor plate if necessary.

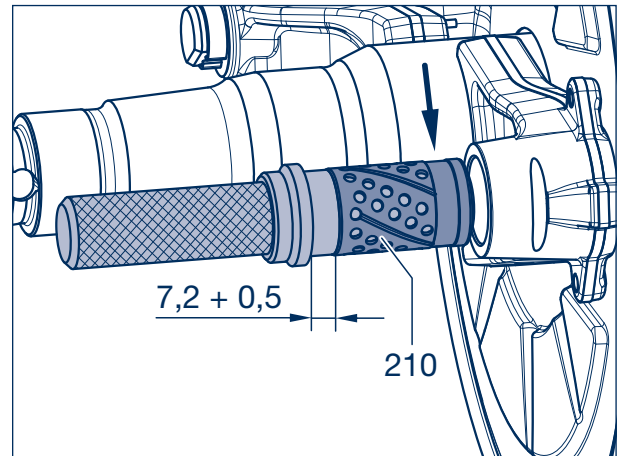

Picture 4

- [9] Insert shaft seal (258) with the open side facing the automatic slack adjuster (280).



**Repair guide!**  
Note the mounting direction of shaft seal (258).

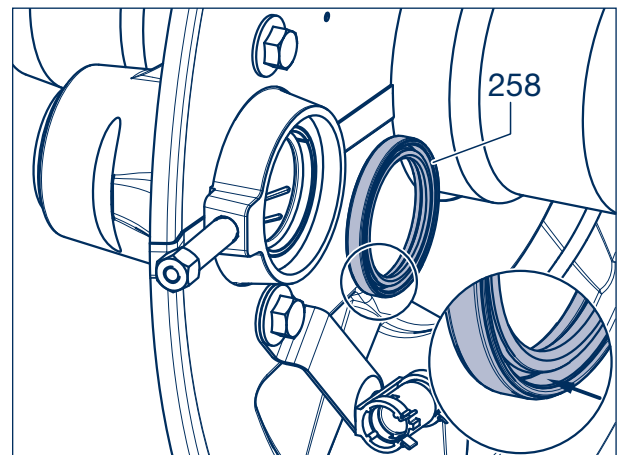

Picture 5

- [10] Insert circlip (250) into the groove, push combined seal (252) and O-ring (256, green,  $\text{Ø} 40 \times 2.5$ ) up to the bearing seat.
- [11] Insert an O-ring (255, black,  $\text{Ø} 37 \times 2.6$ ) into the middle groove (arrow).
- [12] Grease bearing with BPW special longlife grease ECO-Li<sup>Plus</sup>.

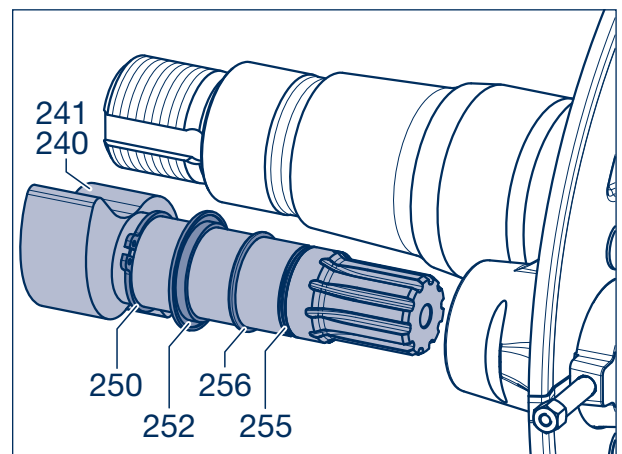

Picture 6

[13] Introduce the short camshaft into the brake carrier.



**Repair guide!**  
**Brake camshafts are not interchangeable left to right.**

[14] Check that the brake camshaft rotates freely.

[15] Slide seal (260) onto camshaft (240, 241).

[16] Grease all bearing surfaces of the brake camshaft via the grease nipples, using BPW special longlife grease ECO-Li<sup>Plus</sup>.

 Fit slack adjuster, see chapter 12.

 Fit brake shoe and the complete hub unit, see chapter 8.

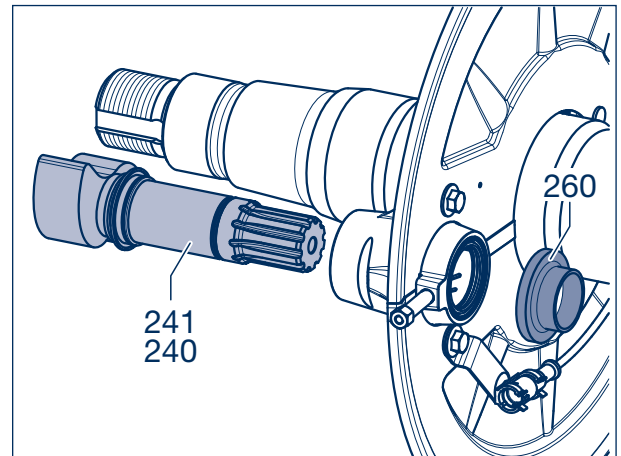

Picture 7

## 12 Automatic Slack Adjuster ECO-Master

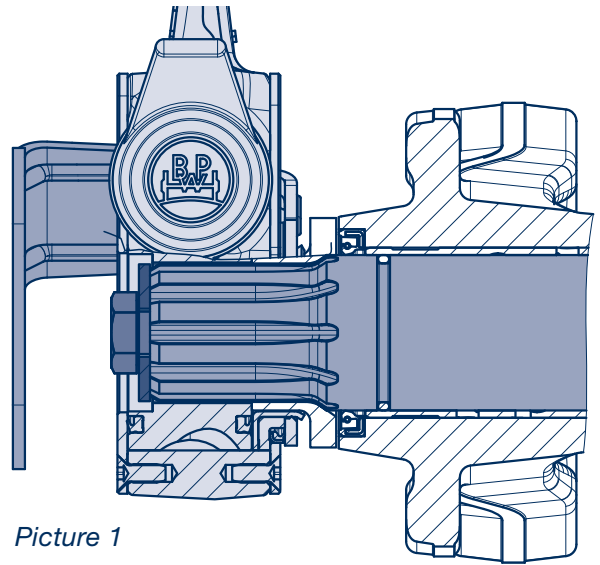
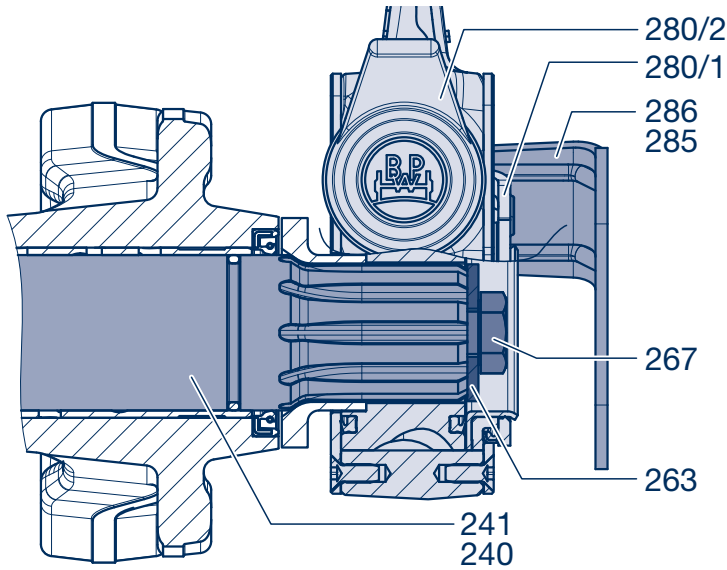

Picture 1

- [1] Grease spline of brake camshaft 240, 241 with BPW special longlife grease ECO-Li<sup>Plus</sup>.
- [2] Slide automatic slack adjuster ECO-Master (280) onto the brake camshaft.
- [3] In this position, fit yoke of the reaction bracket (285, 286) onto control lever (280/1) (note left and right versions).
- [4] Clean end of brake camshaft. The thread must be dry and free of grease.



**Repair guide!**  
**Fit new screw (267).**  
**(Secure with thread-lock adhesive.)**

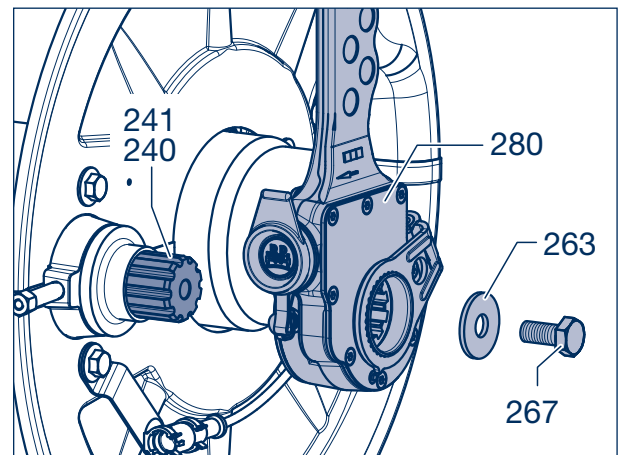

Picture 2

- [5] Screw and washer mounting (267, SW 19) torque - 69 Nm.
- [6] Check the brake camshaft (240, 241) rotates freely.  
 Admissible axial play: max 3 mm.
- [7] Remove cap (280/2), press down clutch sleeve with ring spanner (SW 19, arrowed) and, by turning to left or right, align the bolt hole in brake lever with round hole or end of slot in the yoke.

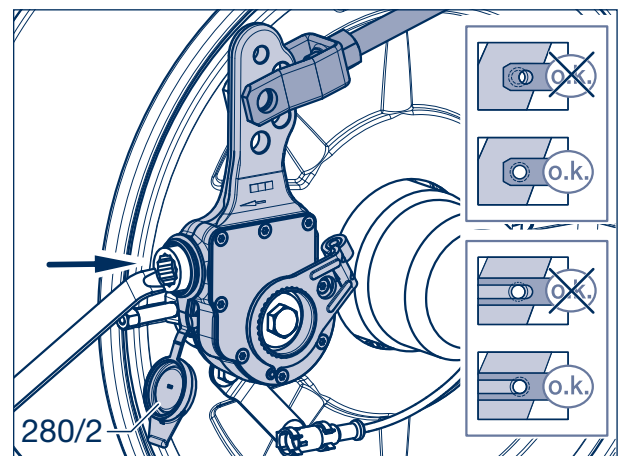

Picture 3

- [8] Insert clevis pin and lock.
- [9] Insert return spring (295).



**Note:**  
The arrangement of the pull-off spring (295) may be different to that shown.

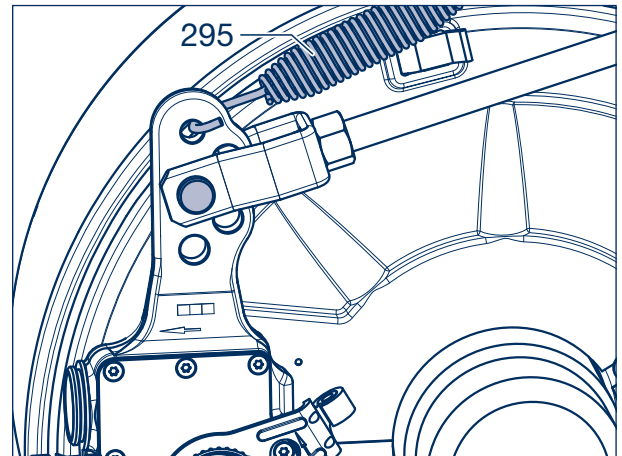

Picture 4

- [10] Holding the clutch sleeve down, press control lever (280/1) in the direction of the arrow until it reaches the endstop.
- [11] The lug on the control lever will now point to the control point.
- [12] Fit locating point support (285, depending on the manufacturer).



**Repair guide!**  
Control lever lug must align to the control point after fitting the locating point support! (Basic setting)

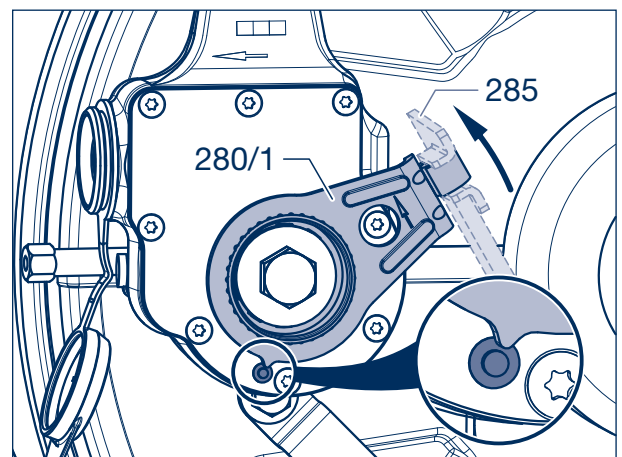

Picture 5

### Adjusting the brake:

- [13] Set play "a" to 10 - 15 % of the connected brake lever length "B" by turning the adjusting hexagon (keep clutch sleeve pressed down). E.g. if brake lever length 150 mm = play 15 - 22 mm.
- [14] When the brake is applied, the cylinder push rod and slack adjuster must be at an angle of approximately 90° to each other.
- [15] Grease all points with BPW special longlife grease ECO-Li<sup>Plus</sup>.
- [16] Fit plastic cap (280/2).

 The setting of the ECO-Master must be readjusted after a change or renewal of the brake cylinder, brake camshaft or the automatic slack adjuster.

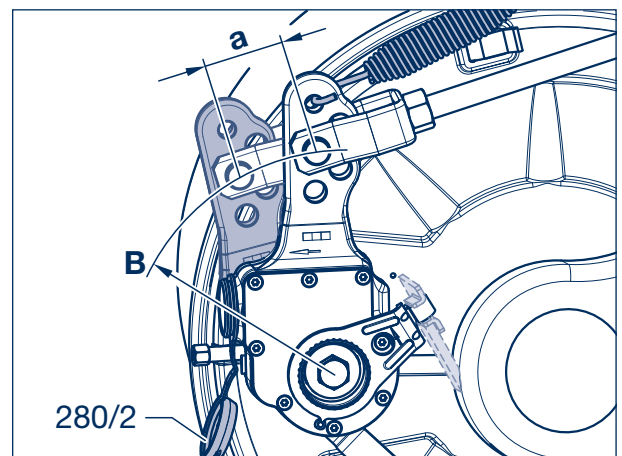

Picture 6

**BPW is a globally leading manufacturer of intelligent running gear systems for trailers and semi-trailers. As an international mobility and system partner, we offer a wide range of solutions for the transport industry from a single source, from axle to suspension and brake to user-friendly telematics applications.**

**We thereby ensure outstanding transparency in loading and transport processes and facilitate efficient fleet management. Today, the well-established brand represents an international corporation with a wide product and service portfolio for the commercial vehicle industry. Offering running gear systems, telematics, lighting systems, composite solutions and trailer superstructures, BPW is the right system partner for automotive manufacturers.**

**BPW, the owner-operated company, consistently pursues one target: To always give you exactly the solution which will pay off. To this end, we focus our attention on uncompromising quality for high reliability and service life, weight and time-saving concepts for low operating and maintenance costs as well as personal customer service and a close-knit service network for quick and direct support. You can be sure that with your international mobility partner BPW, you always use the most efficient method.**

# Your partner on the path to economic viability



**BPW Bergische Achsen Kommanditgesellschaft**

Postbox 12 80 · 51656 Wiehl, Germany · Phone +49 (0) 2262 78-0  
info@bpw.de · [www.bpw.de](http://www.bpw.de)