

W
BW
GW

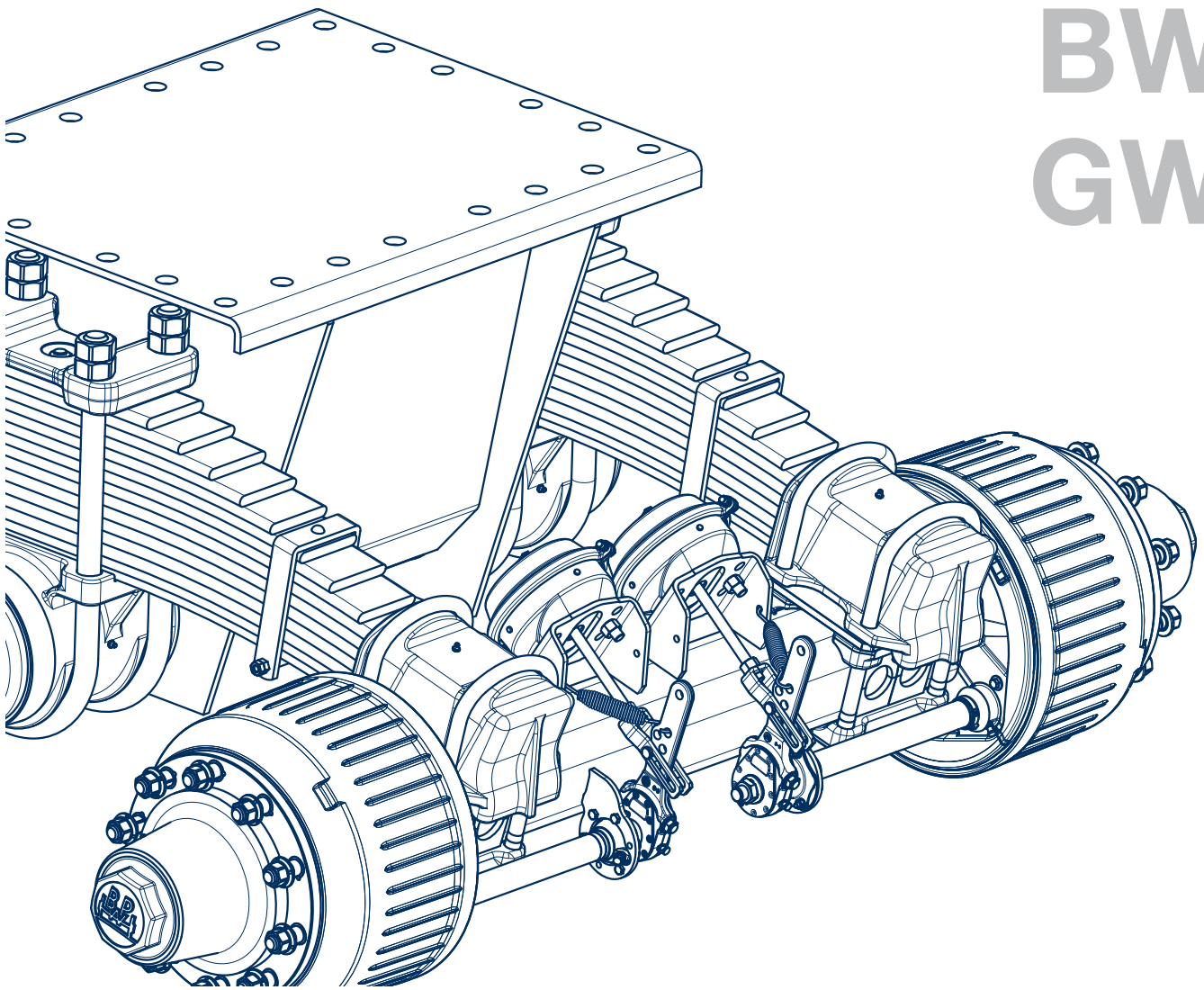

Workshop manual

Mechanical suspensions BPW,
series ECO Cargo W / BW / GW



Valid: 01.08.2014

3rd edition

Subject to change without notice.

Current versions and additional information can be found online at www.bpw.de.

Contents

◎ 1. Product identification	Page 3
1.1 Explanation of BPW axle type codes (extract)	Page 3
1.2 Explanation of BPW code numbers (extract)	Page 4
◎ 2. Special tools	Page 6
◎ 3. Exploded view / Name	Page 8
◎ 4. Tightening torques	Page 11
◎ 5. Safety regulations, safety information	Page 12
5.1 Safety regulations	Page 12
5.2 Safety information	Page 13
◎ 6. Care and Maintenance	Page 14
◎ 7. Replacing leaf springs (series ECO Cargo W)	Page 18
7.1 Removing	Page 18
7.2 Installing	Page 20
◎ 8. Replacing spring hanger (series ECO Cargo W)	Page 24
8.1 Removing	Page 24
8.2 Installing	Page 26
◎ 9. Removing and installing axle (series ECO Cargo W)	Page 28
9.1 Removing	Page 28
9.2 Installing	Page 28
◎ 10. Spring hanger / Trunnion axle mounting (series ECO Cargo BW / GW)	Page 30
10.1 Removing	Page 30
10.2 Installing	Page 31
◎ 11. Replacing leaf springs (series ECO Cargo BW / GW)	Page 33
11.1 Removing	Page 33
11.2 Installing	Page 34
◎ 12. Removing and installing axle (series ECO Cargo BW / GW)	Page 38
12.1 Removing	Page 38
12.2 Installing	Page 38

- Refer to appropriate workshop manuals for axle repairs

1 Product identification

1.1 Explanation of BPW axle type codes (extract)

Example:

H	Z	F	H	W	2/	12010	B	ECO ^{Plus}				
									Axle series	Brake	Tyre	
H										H..	SN 420	20" / 22.5" / 24"
a.o.										Further axle types see BPW type designations		
S										For single wheels, wheels without offset		
Z										For twin wheels		
I										Wheel spiders for TRILEX wheel rims, single wheels		
IZ										Wheel spiders for TRILEX wheel rims, twin wheels		
F										Wheel studs M 22x1.5 without wheel nuts; order wheel nuts for stud or spigot alignment separately		
M										For spigot alignment		
H										For hanging boosters		
				W								Tandem axle assembly, rigid, with two leaf springs and support axle, bearing blocks or high mounting bracket between the leaf springs, with sliding bearing bushes
				BW								Tandem axle assembly, rigid, with two leaf springs and support axle, bearing blocks above the leaf springs, with bronze bushes
				GW								Tandem axle assembly, rigid, with two leaf springs and support axle, bearing blocks above the leaf springs, with rubber bushes
					2/							Tandem axle suspension
						8010 to 20010						Axle load (kg) + quantity of wheel studs per hub
							B	Ausf.- Index B		Version for extreme conditions		
							C	C		Version for Highway conditions		
							-1	-1		Type of hub bearings (14 tons)		
							-20	-20		Axle beam wall thickness (eg. 20 mm)		
							7/8 IN	7/8 IN		Radbolzen-Ausführung		
							ECO^{Plus}	Axle with ECO ^{Plus} hub system				
							ECO MAXX	Weight-optimized axle with ECO hub system				
							ECO	Axle with ECO hub system				
							MAXX	Axle with conventional hub bearing				

1.2 Explanation of BPW axle code numbers (extract)

Example:

32.	50.	744.	000			
				1. + 2. digit		
22.		Tandem axle assembly				
32.						
				3. + 4. digit: Axle load and bearing		
				Axle load	Roller bearings	Bearing generation
08.		8000 - 9000 kg		33116 / 32310	Conventional hub bearing	
09.		8000 - 9000 kg		33116 / 32310		
10.		10000 - 12000 kg		33118 / 33213		
14.		13000 - 14000 kg		32219 / 33215		
16.		16000 - 18000 kg		32222 / 33214		
20.		20000 kg		32224 / 32316		
38.		8000 - 9000 kg		33116 / 32310	ECO hub bearing system	
40.		10000 - 12000 kg		33118 / 33213		
44.		13000 - 14000 kg		32219 / 33215		
48.		8000 - 9000 kg		33118 / 33213	ECO ^{Plus} hub bearing system	
50.		10000 - 12000 kg		33118 / 33213		
				5. - 7. digit: Designation of wheel brake		
501. to 839.		For explanation of code number, see EL-HKN or BPW code number designation				
				8. - 10. digit: Consecutive number		
000 to 999		Consecutive number 000 - 999				

2 Special tools

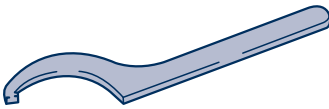
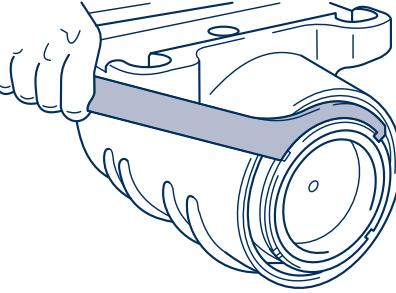
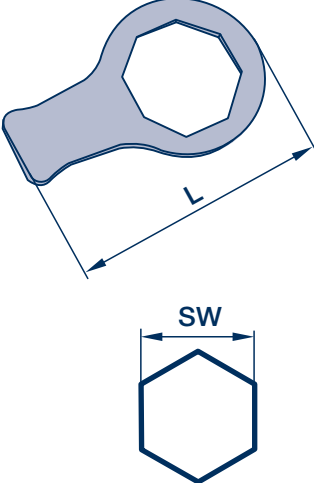
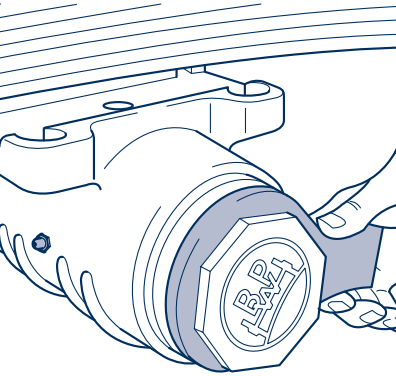
Number	Description	Illustration of tool	Tool in operation
1	Hook wrench BPW no. Ø 135 - 145 mm (9 - 12 t): 02.3516.03.00 Ø 205 - 220 mm (14 - 20 t): 02.3516.04.00		
2	Wrench for hub caps on trunnion axle BPW no. SW = 120 mm 03.339.05.02.0 SW = 130 mm 03.339.05.03.0		





3 Exploded view

BPW tandem axle assembly, series ECO Cargo W

high mounting bracket

lower mounting bracket

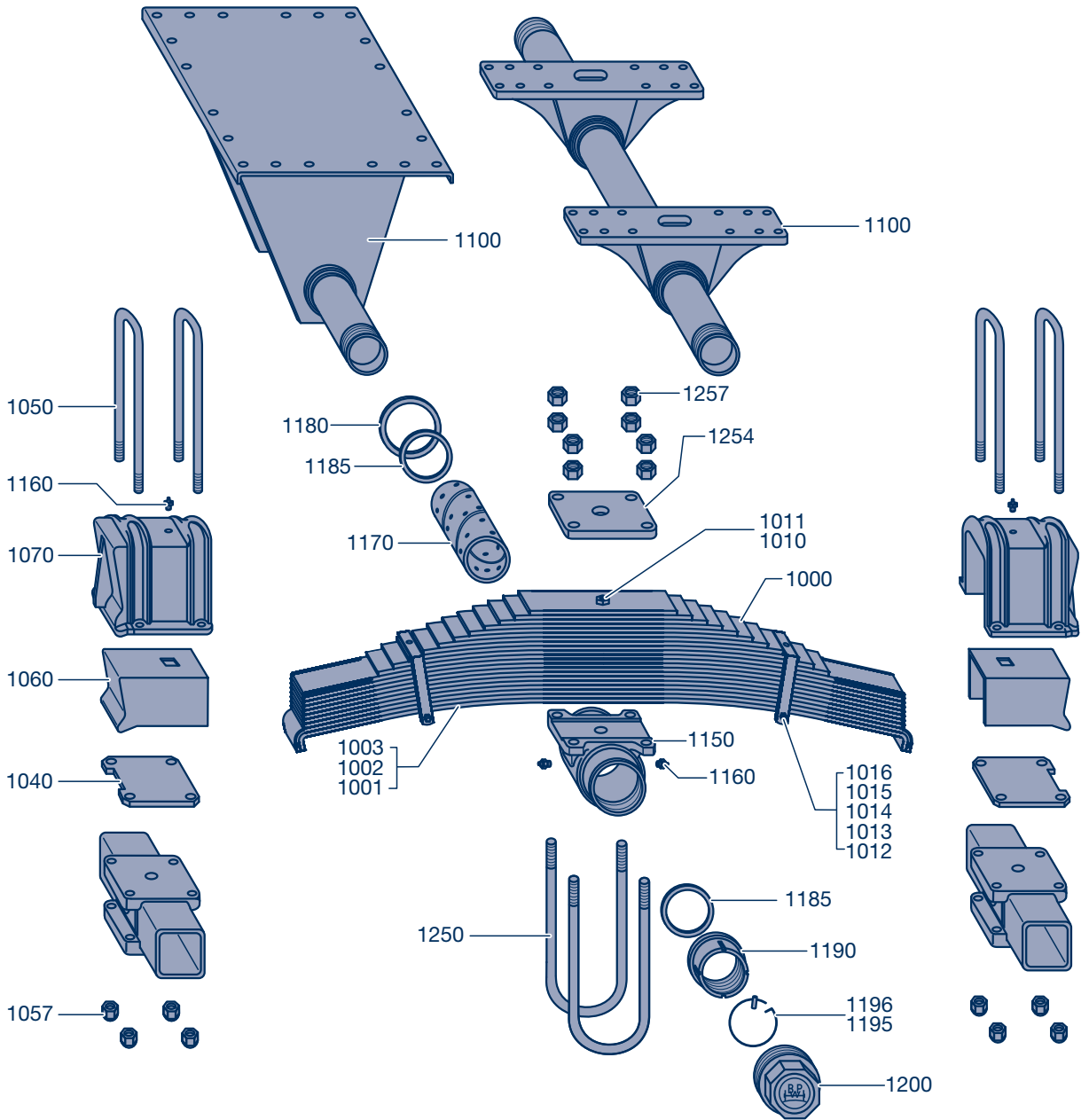

BPW tandem axle assembly, series ECO Cargo BW / GW

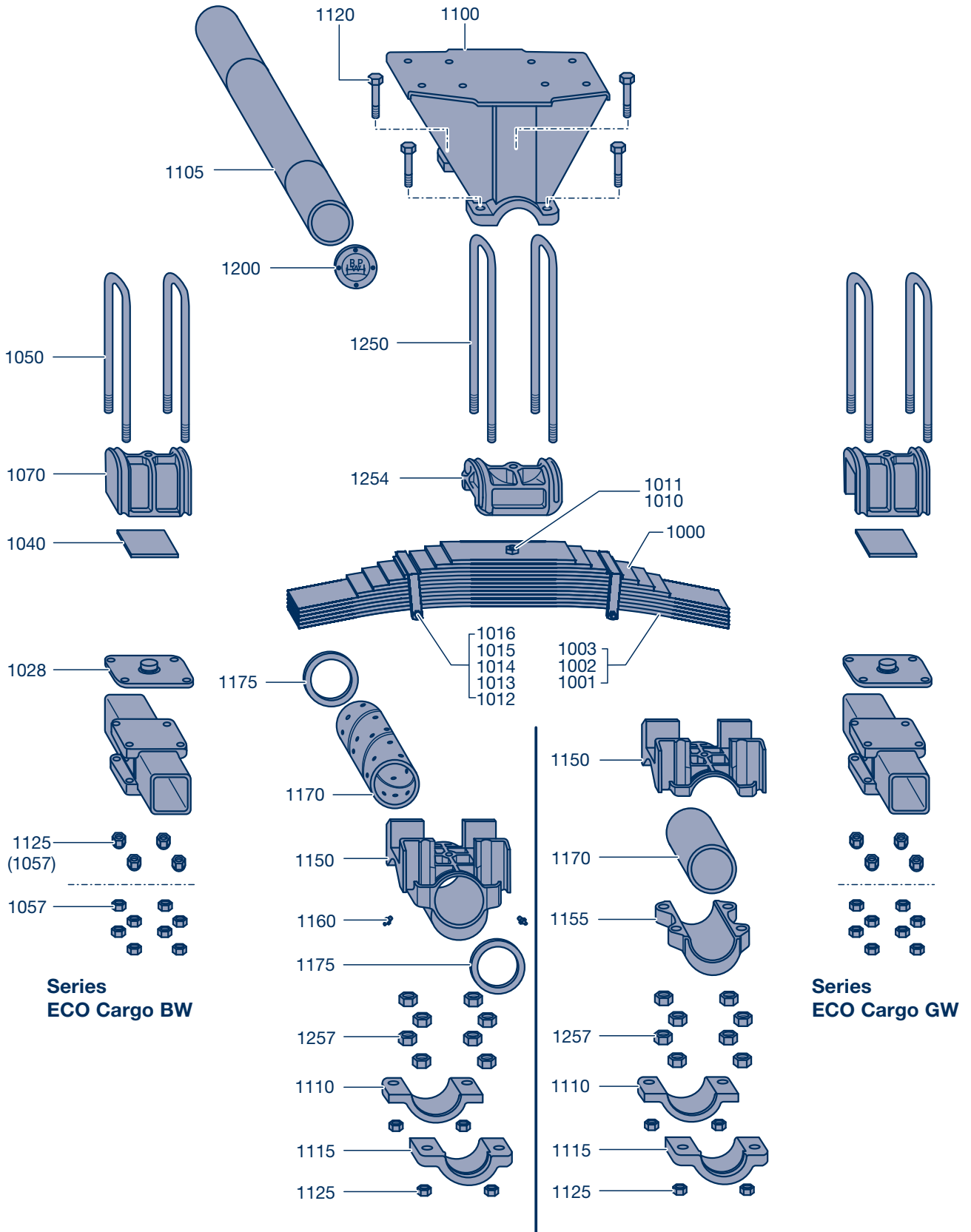

Name

Series ECO Cargo W

Pos.	Name
1000	Leaf spring
1001	1. Spring leaf
1002	2. Spring leaf
1003	3. - 8. Spring leaf
1010	Spring centre bolt
1011	Hexagon nut
1012	Spring clamp
1013	Button head rivet
1014	Hexagon screw
1015	Hexagon nut
1016	Tube
1040	Plate
1050	Spring U-bolt
1057	Lock nut
1060	Spring cushion
1070	Spring housing
1100	Trunnion axle (mounting bracket)
1150	Trunnion block
1160	Grease nipple
1170	Bush
1180	Ring
1185	Ring
1190	Nut
1195	Hooked spring ring
1196	Bolt
1200	Hub cap
1250	Spring U-bolt
1254	Spring plate
1257	Hexagon nut

Series ECO Cargo BW, GW

Pos.	Name
1000	Leaf spring
1001	1. Spring leaf
1002	2. Spring leaf
1003	3. - 6. Spring leaf
1010	Spring screw
1011	Hexagon nut
1012	Spring clamp
1013	Button head rivet
1014	Hexagon screw
1015	Hexagon nut
1016	Tube
1028	Spring pad
1040	Plate
1050	Spring U-bolt
1057	Hexagon nut
1070	Spring housing
1100	Trunnion block
1105	Trunnion axle beam
1110	Bearing cap
1115	Bearing cap
1120	Hexagon screw
1125	Lock nut

Series ECO Cargo BW

Pos.	Name
1150	Trunnion block
1175	Ring

Series ECO Cargo GW

Pos.	Name
1150	Trunnion block, upper
1155	Trunnion block, lower
1160	Grease nipple
1170	Bush
1200	Hub cap
1250	Spring U-bolt
1254	Spring housing
1257	Hexagon nut

Tightening torque **4**

Pos.	Description	Thread / Spanner size	Tightening torques
1011	Nut for spring centre bolt	M 16 - 8 / SW 24 M 20 x 2 - 8 / SW 30	M = 163 Nm M = 335 Nm
1015	Nut for the spring clamp	M 12 x 1.5 - 8 / SW 19	M = 69 Nm
1057/ 1125	Nut for the „U” bolt and spring housing	M 20 - 10 / SW 30 M 24 - 10 / SW 36	M = 450 Nm M = 700 Nm
1125	Nuts at bearing caps (series ECO Cargo BW / GW)	M 20 / SW 30 M 24 / SW 36	M = 320 Nm M = 570 Nm
1200	Caps on trunnion axle (series ECO Cargo W)	M 170 x 3 / SW 130 M 230 x 3 / SW 120	M = 900 Nm M = 900 Nm
1257	Nuts of trunnion U-bolts	M 30 x 2 - 8 / SW 46 M 36 - 8 / SW 55	M = 980 Nm M = 1555 Nm

5 Safety regulations, safety information

5.1 Safety regulations

- All work must be performed by trained mechanics at competent repair facilities or authorised specialist companies who have access to all relevant tools and have acquired the knowledge required for this work. Anyone who performs maintenance and repair work must be trained in automotive mechanics and already have experience in repairing trailers. Anyone who performs brake work must be trained in brake systems.
 - Comply with local safety regulations.
 - The relevant operation and service regulations as well as safety regulations of the vehicle manufacturer and of the manufacturers of other vehicle parts must be adhered to.
 - The vehicle must be prevented from moving during repair work. Please observe the relevant safety regulations for repair work on commercial vehicles, in particular the safety regulations for jacking up and securing the vehicle.
 - Before commencing any welding operations, protect leaf springs, spring clips, bushings and plastic parts from weld spatter.
 - The earth terminal must under no circumstances be attached to the leaf springs, spring U-bolts or hubs.
 - Do not perform welding on leaf springs and bearing blocks.
 - During repair work, make sure that the brake is not operated inadvertently.
 - Do not perform repair work unless wearing protective clothing (gloves, safety boots, safety goggles, etc.) and using the recommended tools.
 - Only use recommended tools.
 - When working with heavy components (leaf springs, axle beams, bearing blocks, brake drums and hub assemblies) seek assistance from a second person.
 - All air lines and components must be depressurised before being removed.
 - Following each repair, perform a function check or a test drive in order to make sure that the brakes and suspensions are functioning correctly. New brake linings only have maximum effect after a few braking actions. Avoid hard braking.
 - All exchanged components must be reused or disposed in accordance with the applicable environmental regulations, laws and directives.
 - The remaining thickness of the brake lining and the condition of the brake drum must be visually inspected at regular intervals with respect to the way in which the vehicle is used (see BPW maintenance instructions).
 - Tighten all fixings to the recommended tightening torque.
-

5.2 Safety information

This workshop manual contains different types of safety instructions, each of which is designated an icon and a key word. The key word describes the severity of the potential danger.



Warning!

Possible potential danger of serious or fatal injury (severe injury or death).

Caution!

Possible dangerous situation (slight injury or damage to property).



Repair Guide!

Risk of damage to property or consequential damage if this information is not observed.



Note!

Application hints and especially useful information.

It is essential that all maintenance work is carried out in accordance with the prescribed intervals in order to maintain the safe operation and roadworthiness of the trailer. The relevant operation and service regulations of the vehicle manufacturer and of the manufacturers of other vehicle parts must also be adhered to. Rectification of any defects which are discovered or replacement of worn parts should be carried out by a BPW Service Centre or BPW Direct Service Partner unless the vehicle owner has the facilities, equipment and workshop manuals and possesses an official certificate to perform interim inspections or special brake inspections.

When installing spare parts, it is strongly recommended that only original BPW components are used. Parts approved by BPW for trailer axles and suspensions regularly undergo special test procedures. BPW accepts product responsibility for them.

However, BPW cannot assess every single third-party product as to whether it can be used for BPW trailer axles and suspensions without any risk to safety. This applies even if such products have already been tested by an accredited test authority.

The warranty becomes null and void if spare parts other than original BPW parts are used.

6 Care and Maintenance

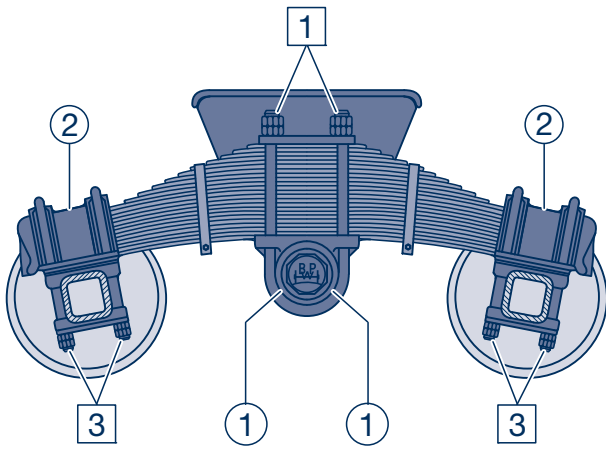

Series ECO Cargo W

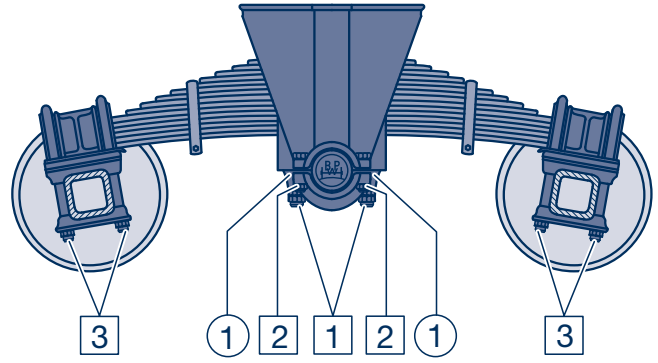

Series ECO Cargo BW / GW

Lubrication and maintenance work

Overview

For detailed description see pages 15 and 16

	initially after 2 weeks	every 6 weeks	every 6 months ¹⁾
--	-------------------------	---------------	------------------------------

<input type="radio"/> Lubricate			
<input type="radio"/> 1	Grease axle support bearing series ECO Cargo W, BW using BPW special longlife grease ECO-Li ^{Plus} .	<input type="radio"/> 1 ¹⁾	<input type="radio"/> 1 ¹⁾
<input type="radio"/> 2	Grease spring housing series ECO Cargo W using BPW special longlife grease ECO-Li ^{Plus} .	<input type="radio"/> 2	<input type="radio"/> 2

<input type="checkbox"/> Maintenance work			
<input type="checkbox"/> -	Visual inspection. Check all component parts and welding seams for wear and damage.		<input type="checkbox"/> -
<input type="checkbox"/> 1	Check centre trunnion „U” bolts for tightness. M 30 x 2 (SW 46) M = 980 Nm M 36 (SW 55) M = 1555 Nm	<input type="checkbox"/> 1	<input type="checkbox"/> 1
<input type="checkbox"/> 2	Check fixing bolts on bearing caps for tightness. M 20 (SW 30) M = 320 Nm M 24 (SW 36) M = 570 Nm		<input type="checkbox"/> 2
<input type="checkbox"/> 3	Check axle „U” bolts for firm seating. M 20 (SW 30) M = 450 Nm M 24 (SW 36) M = 700 Nm	<input type="checkbox"/> 3	<input type="checkbox"/> 3

¹⁾ under extrem conditions, lubricate with more frequency.

Note: Components that have damages due to improper mounting are to be exchanged after a review by a BPW Service Centre.

○ Lubrication work

- ① **Support axle (series ECO Cargo W, BW)**
 – every six weeks, initially after 2 weeks –
 – under extreme conditions, lubricate with more frequency –

Lift trailer to take pressure off the bearings.
 Grease lubrication nipple front and rear on the bearing brackets of the support axle using BPW special longlife grease ECO-Li^{Plus} until fresh grease emerges (not applicable to axle assembly series ECO Cargo GW = rubber bush)

At extremely low temperatures (-30° C up to 50° C) a grease with correspondingly lower consistency class should be used - such as BPW ECO-Li Polar.

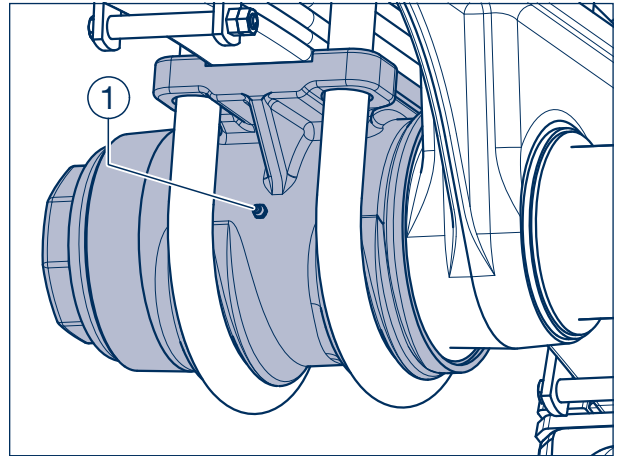

Series ECO Cargo W

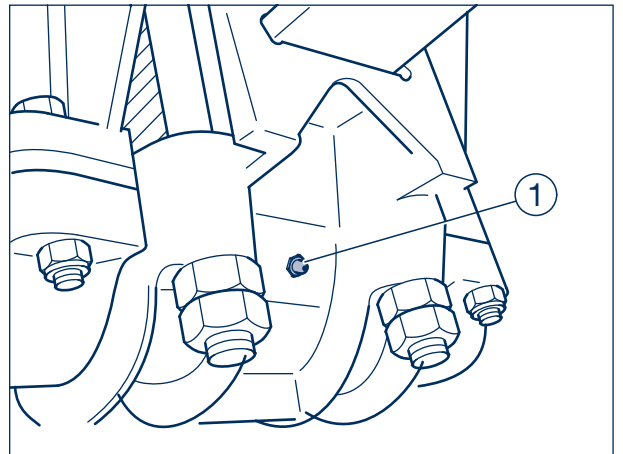
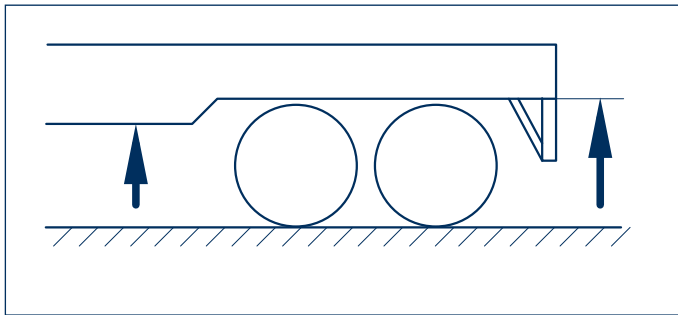

Series ECO Cargo BW

- ② **Spring housing (series ECO Cargo W)**
 – every six weeks, initially after 2 weeks –

Grease lubrication nipples on the spring housing using BPW special longlife grease ECO-Li^{Plus}.

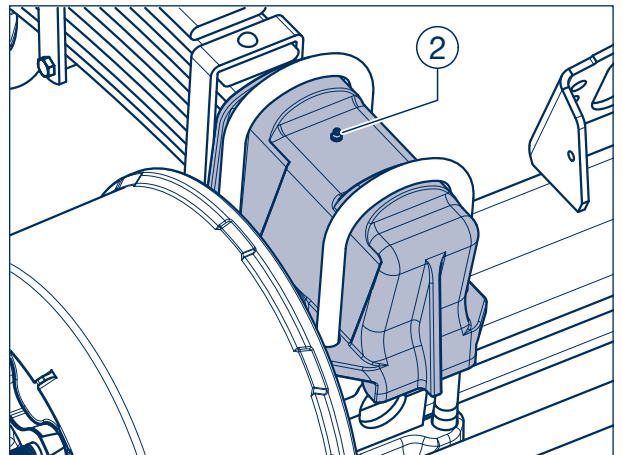

Series ECO Cargo W

6 Care and Maintenance

- **Visual inspection**
– every six months –

Check all component parts and welding seams for wear and damage.

- 1 **Check centre trunnion „U” bolts for tightness**
– every six months, initially after 2 weeks –

Check spring U-bolts for tightness.
If necessary loosen lock nuts, tighten nuts alternately to the prescribed torque, a bit at a time, then relock.

Tightening torques:

M 30 x 2 (SW 46) M = 980 Nm
M 36 (SW 55) M = 1555 Nm

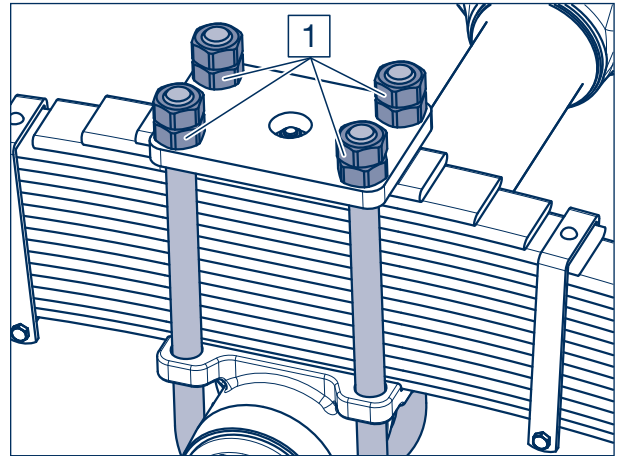

- 2 **Check fixing bolts on bearing caps for tightness**
– every six months –

Check the fastening screws on the cover plates of support axle for tightness.

Tightening torques:

M 20 (SW 30) M = 320 Nm
M 24 (SW 36) M = 570 Nm

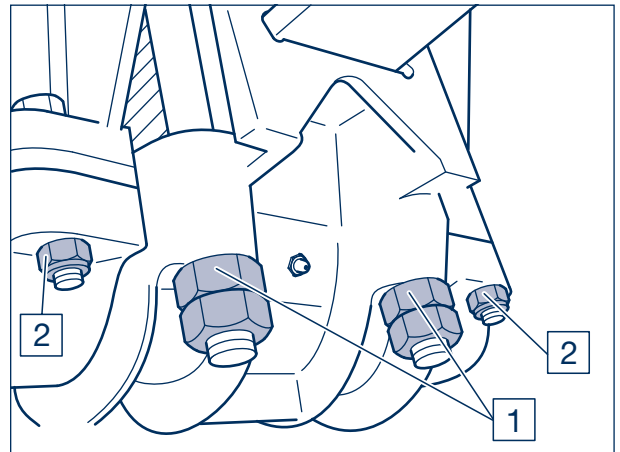

- 3 **Check axle „U” bolts for firm seating**
– every six months, initially after 2 weeks –

Check spring U-bolts on the spring housings for tightness.

If necessary loosen lock nuts, tighten nuts alternately to the prescribed torque, a bit at a time, then relock.

Tightening torques:

M 20 (SW 30) M = 450 Nm
M 24 (SW 36) M = 700 Nm

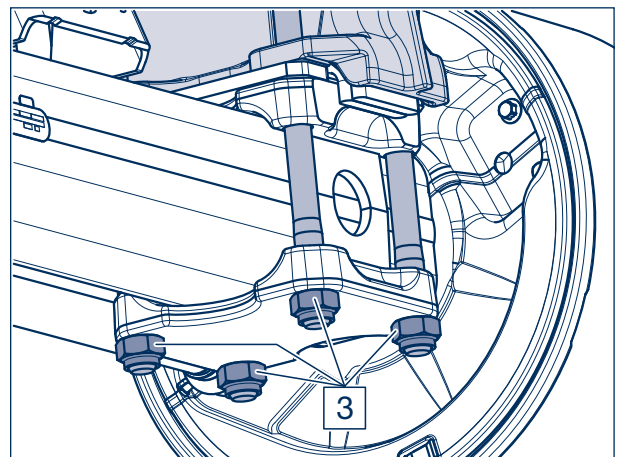

7 Replacing leaf springs (series ECO Cargo W)

7.1 Removing

- [1] Jack the vehicle up on the chassis frame. Securely support the chassis and axle to prevent accidents. Remove the wheels.
- [2] Unscrew the nuts (1257, SW 55) of the trunnion U-bolts (1250).



Caution! RISK OF INJURY
Loosen the nuts (1257) and prevent the U-bolts (1250) from falling. Use a hoist or second person for assistance.

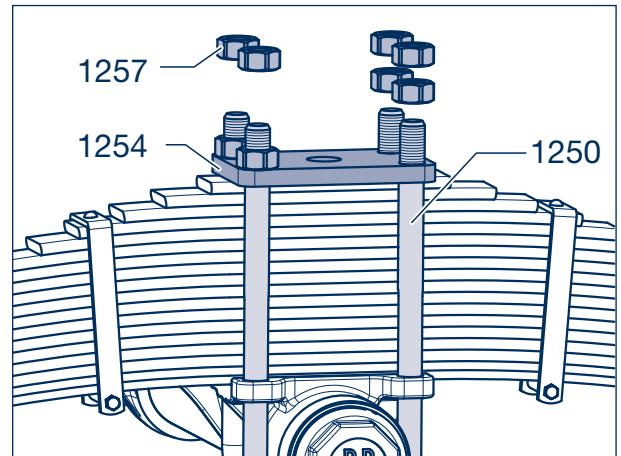

Picture 1

- [3] Lower the U-bolt (1250) clear of the spring plate (1254) and bearing housing (1150).
- [4] Remove the spring plate from the leaf spring (1000).

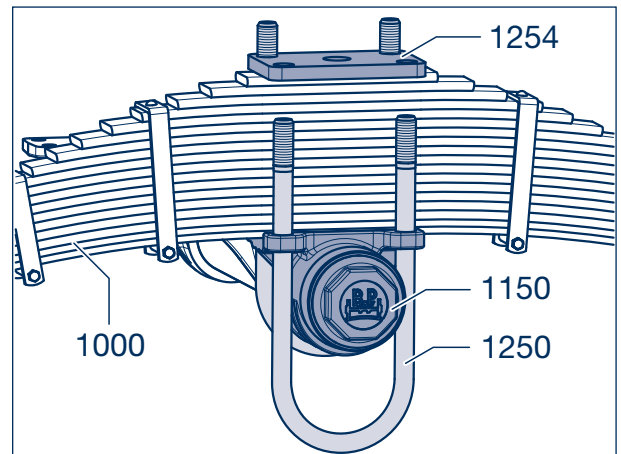

Picture 2

- [5] On both axles remove the nuts (1057 SW 30 / SW 36) from the U-bolts (1050) at the spring housing (1070).
- [6] Remove the U-bolt.

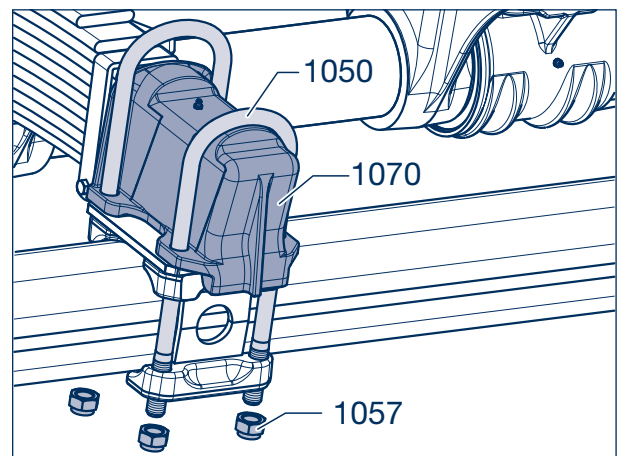

Picture 3

- [7] Remove both spring housings (1070) with the spring cushions (1060).



Caution! RISK OF INJURY

The leaf spring (1000) is now free and must be prevented from falling. Use a hoist or second person for assistance.

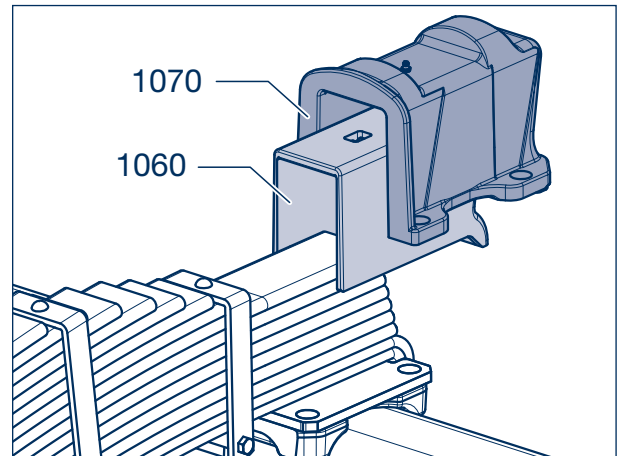

Picture 4

- [8] Raise the spring (1000) to clear the trunnion block (1050).

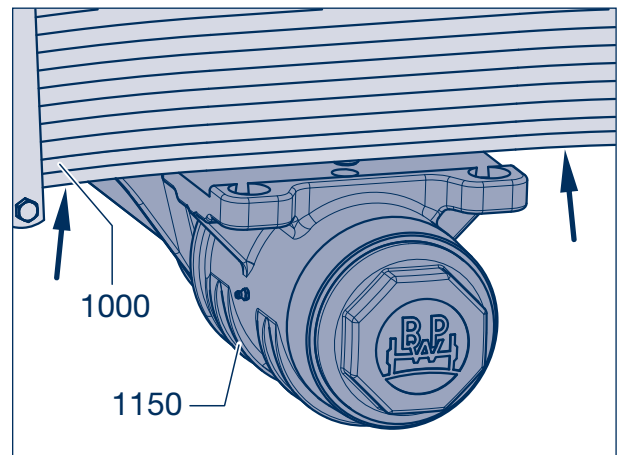

Picture 5



Repair guide!

Disassemble badly rusted springs (1000) which do not slide back into their normal position.

- [9] Put leaf spring on a vice and clamp the head of the spring centre bolt (1010). Secure the leaf spring against falling.
- [10] Remove nuts (1015, SW 19) from the hex screws (1014) of the spring clamp (1012).
- [11] Remove hex bolts and pull out the spring clip spacer tube (1016).

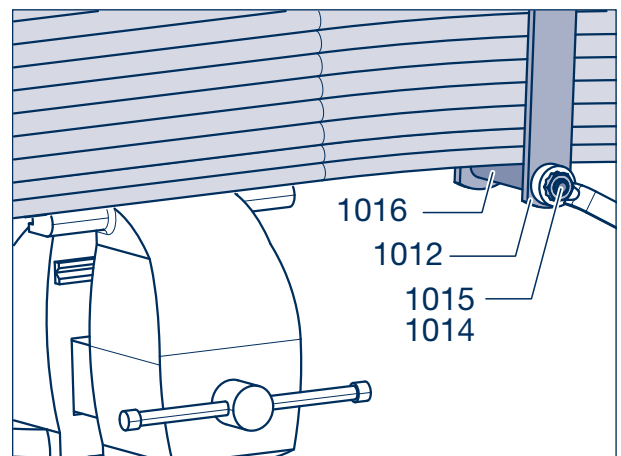

Picture 6

7 Replacing leaf springs (series ECO Cargo W)

- [12] Remove the hex nut (1011, SW 24 / SW 30) from the spring centre bolt (1010).
- [13] Clean the individual leaves (1001 - 1003) thoroughly with a wire brush and check them for cracks.
- [14] Grease the cleaned spring leaves well with graphite grease.

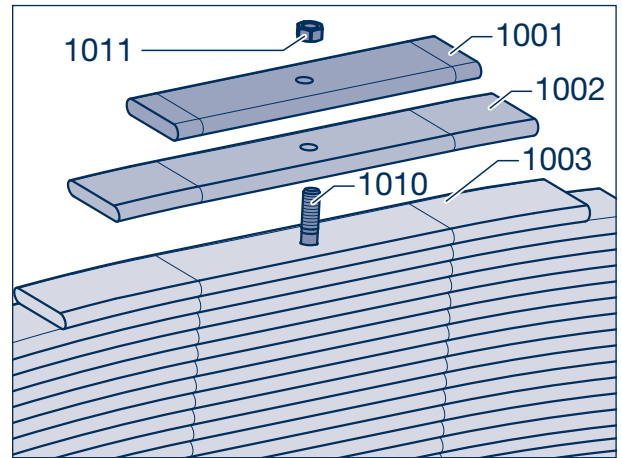

Picture 7

- [15] Greased spring leaves in the correct order mounted on the spring centre bolt (1010).
- [16] Assemble spring clamps (1012) with the hex screws (1014) and the spacer tube (1016).
- [17] Tighten nuts (1015, SW 19) to a tightening torque of 69 Nm. Replace the lock nuts.
- [18] Assemble the hex nut (1011, SW 24 / SW 30) to the spring centre bolt (1010) and tighten to the prescribed torque.

M 16 (SW 24)	M = 163 Nm
M 20 x 2 (SW 30)	M = 335 Nm

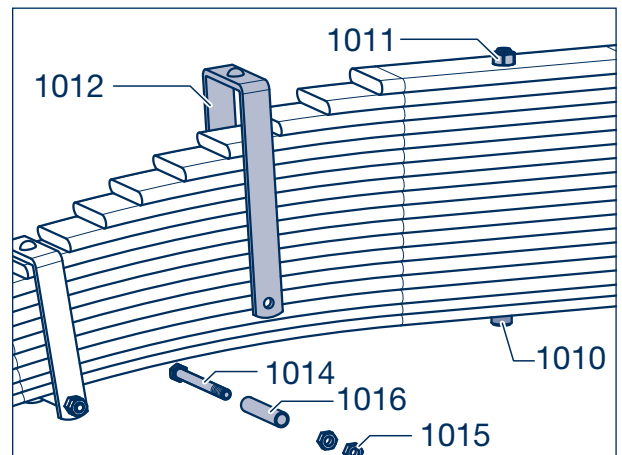

Picture 8

7.2 Installing

- [19] Place the plate (1040) onto the axle plate with the recess (arrow) facing outwards.



Repair guide!
The plate is riveted to the spring on a number of versions.

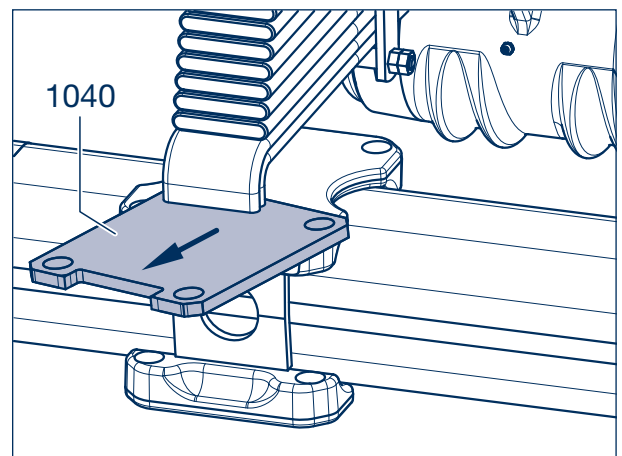

Picture 9

- [20] Align the leaf spring (1000) with the groove of the bearing block (1150) and the recess of the plate (1040) on the axle insert.

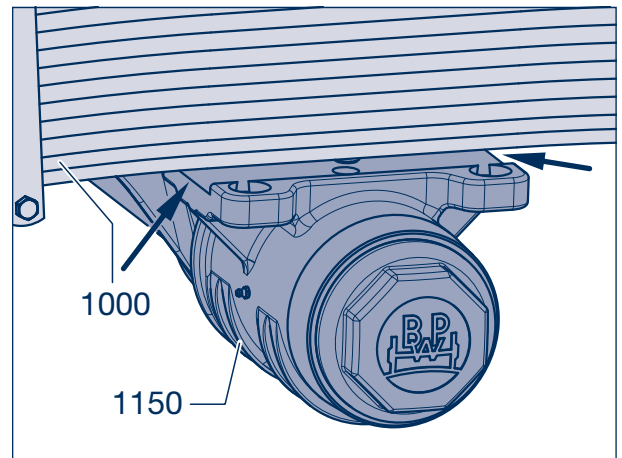

Picture 10

- [21] Using a clamp, press the spring ends together and measure them.

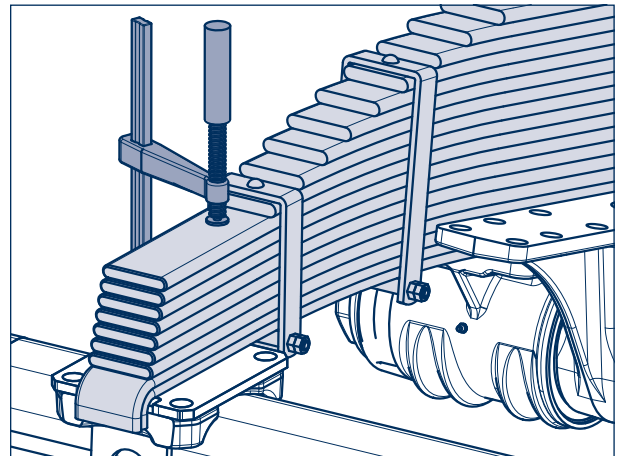

Picture 11



Repair guide!

Height of leaf spring (1000) plus top wall thickness of spring cushion (1060) must correspond to internal height of spring housing (1070).

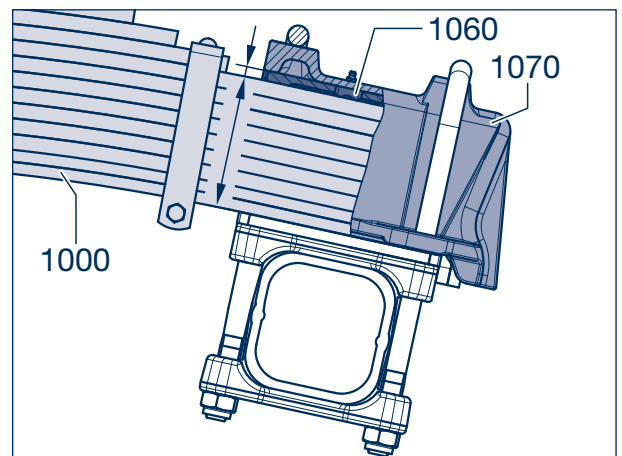

Picture 12

7 Replacing leaf springs (series ECO Cargo W)

- [22] If wear has occurred, the plate (1040) and the spring cushion (1060) should be replaced.
- [23] A plate of appropriate thickness (with lubricating hole) should be inserted in the spring housing (1070), if necessary, to compensate for wear to the leaf spring (1000).
- [24] Tack weld the plate to the spring housing. The leaf spring should be replaced if it is badly worn.

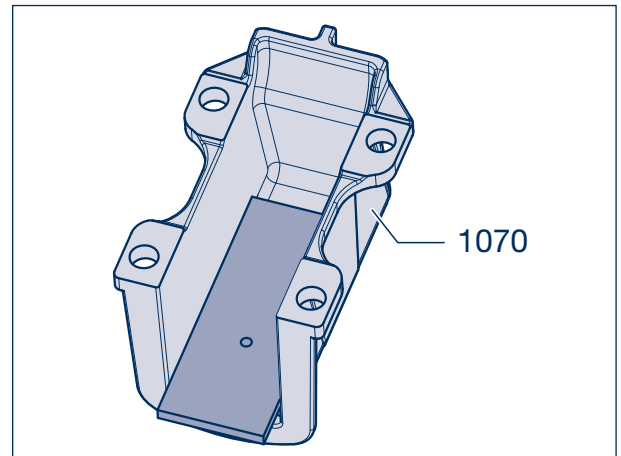

Picture 13

- [25] Place spring cushion (1060) onto the spring. Fit spring housing (1070).

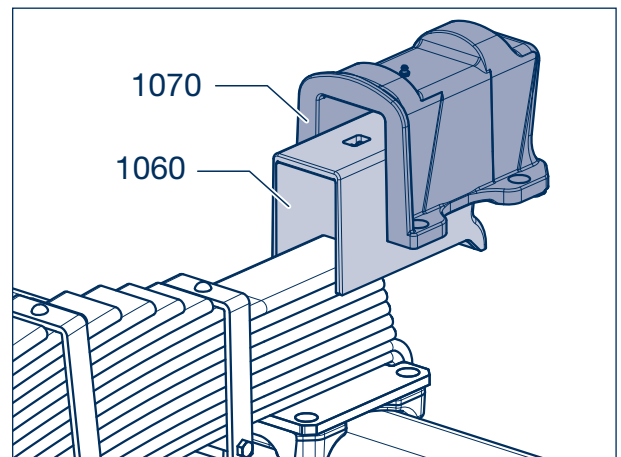

Picture 14

- [26] Fit both new axle U-bolts (1050) onto the spring housing (1070).
- [27] Position the U-bolt until it rests on the spring housing.



Repair guide!
Take care when installing the U-bolt
that the threads are not damaged!

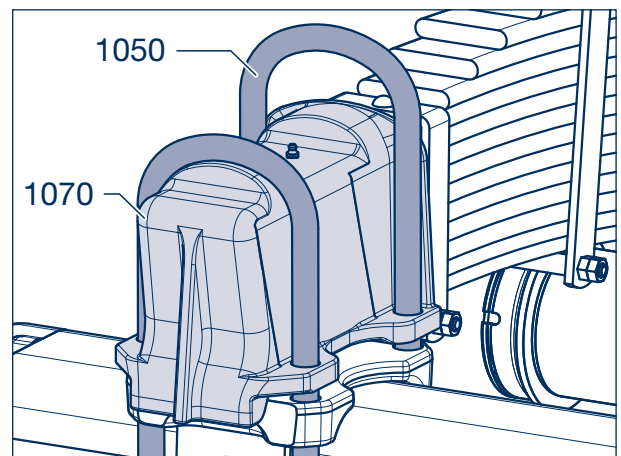

Picture 15

- [28] Screw on the new lock nuts (1057, SW 30 / SW 36) and tighten uniformly and evenly to the specified torque.

Tightening torques:

M 20 (SW 30)	M = 450 Nm
M 24 (SW 36)	M = 700 Nm

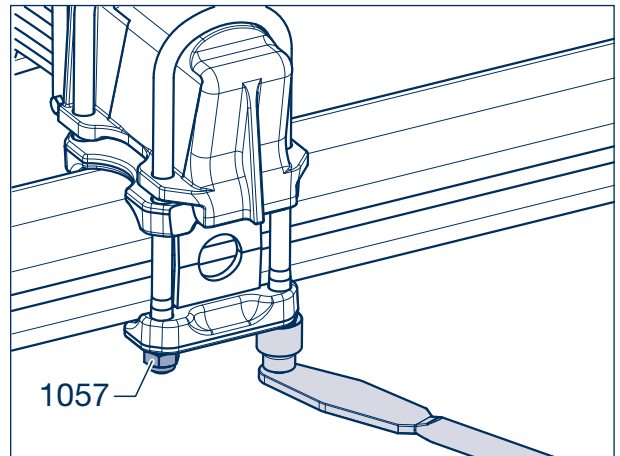

Picture 16



Repair guide!
The end of the spring must contact the spring pads!

- [29] In the same way, install the spring (1000) on the second axle.

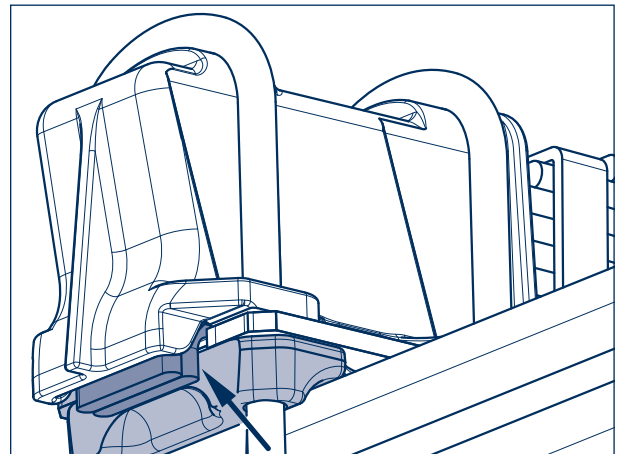

Picture 17

- [30] Insert the trunnion U-bolt (1250) on the trunnion block (1150) and place the top plate (1254) in position.

- [31] Tighten the nuts (1257/1, SW 55) uniformly and evenly to the specified torque.

Tightening torque:

M 36 (SW 55)	M = 1555 Nm
--------------	-------------

- [32] Install the lock nuts (1257/2).

- [33] Measure the distance between axles and, if necessary, correct it, see chapter 6.

- [34] Refit the wheels and lower the vehicle to the ground.

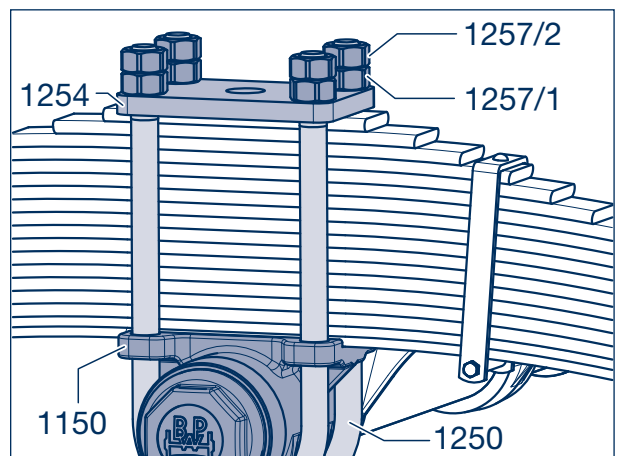

Picture 18

8 Replacing spring hanger (series ECO Cargo W)

8.1 Removing

- [1] Jack the vehicle up on the chassis frame. Securely support the chassis and axle to prevent accidents. Remove the wheels.
- [2] Unscrew the nuts (1257, SW 55) of the trunnion U-bolts (1250).



Caution! RISK OF INJURY!
Loosen the nuts (1257) and prevent the U-bolts (1250) from falling. Use a hoist or second person for assistance.

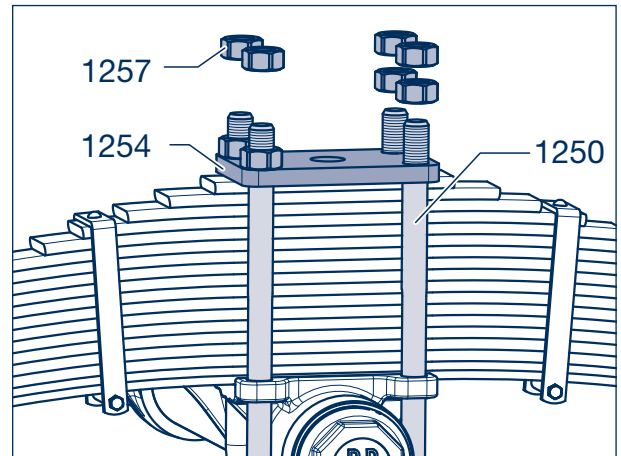

Picture 1

- [3] Lower the U-bolt (1250) clear of the spring plate (1254) and bearing housing (1150).
- [4] Remove the spring plate from the leaf spring (1000).

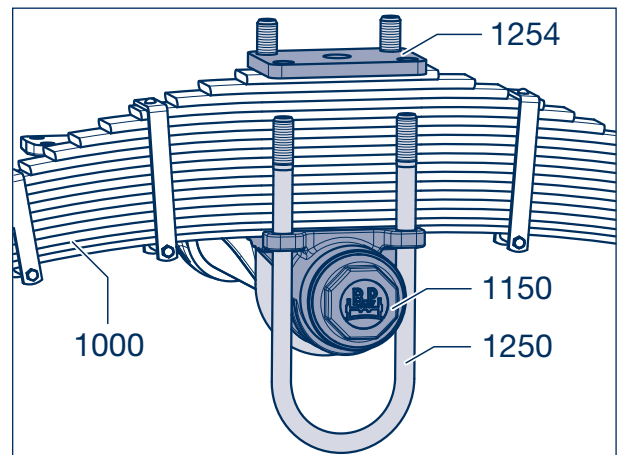

Picture 2

- [5] Raise the spring (1000) until it is free of the trunnion block (1150).
- [6] Remove the cap (1200) from the bearing block with correct cap wrench.
BPW Nr. 03.339.05.02.0 SW 120,
BPW Nr. 03.339.05.03.0 SW 130

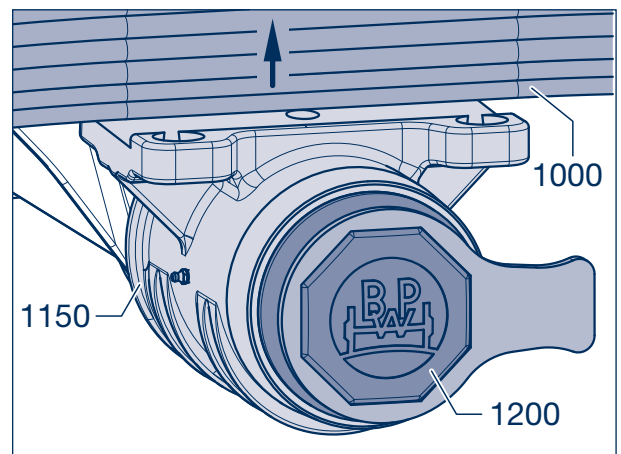

Picture 3

- [7] Remove the hooked snap ring (1195) with the bolt (1196) from the keyed nut (1190).

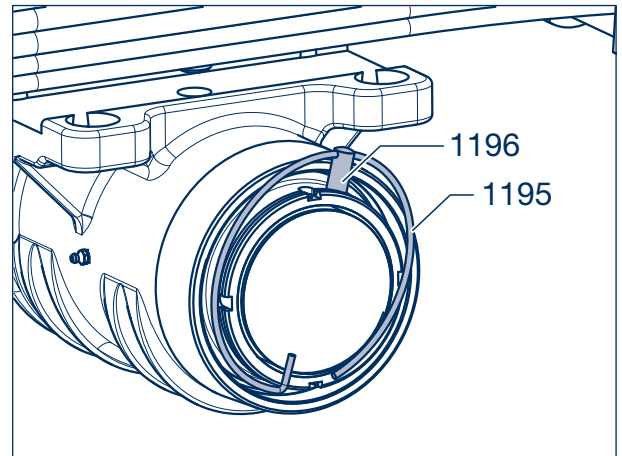

Picture 4

- [8] Unscrew the keyed nut (1190) with the hook wrench.

BPW code number:

02.3516.03.00	9 - 12 t	Ø 135 - 145 mm,
02.3516.04.00	14 - 20 t	Ø 205 - 220 mm.

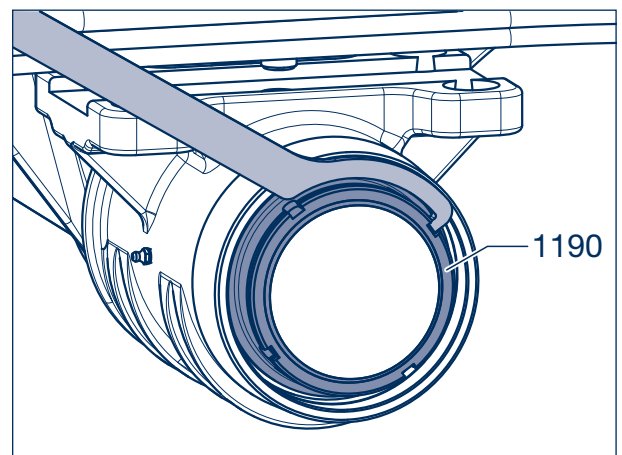

Picture 5

- [9] Remove the trunnion block (1150) with bush (1170), rings (1185) and nylon ring (1180) from the bearing journal of the trunnion bearing (1100).



Caution! RISK OF INJURY!
The bearing block (1150) must be prevented from falling down.
Use a hoist or second person for assistance.

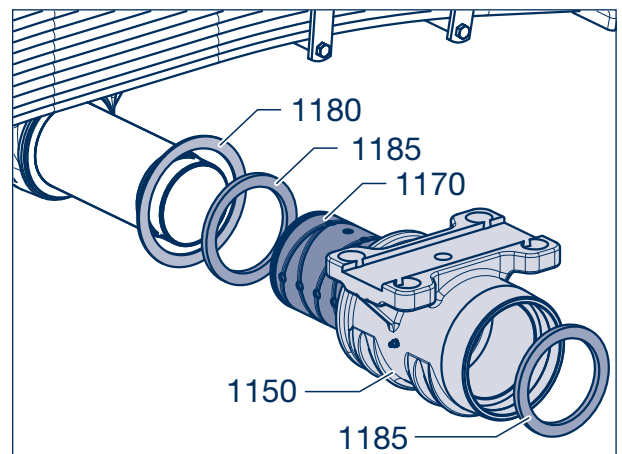

Picture 6

8 Replacing spring hanger (series ECO Cargo W)

8.2 Installing

[10] Apply BPW special longlife grease ECO-Li^{Plus} to the nylon ring (1180), the inner ring (1185) and the bush (1170) on the inside and fit them onto the bearing journal of the trunnion beam (1100).

[11] Press the sealing ring (1180) onto the seat of the trunnion axle.

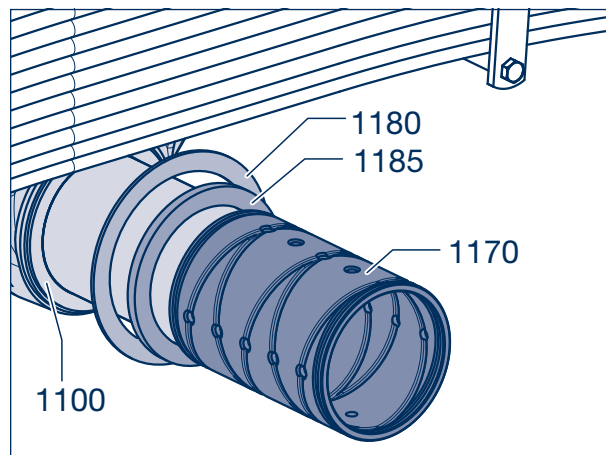

Picture 7

[12] Apply BPW special longlife grease ECO-Li^{Plus} to the outside of the bush (1170).

[13] Push the trunnion block (1150) into place on the journal and place the outer ring (1185) into the bearing journal.

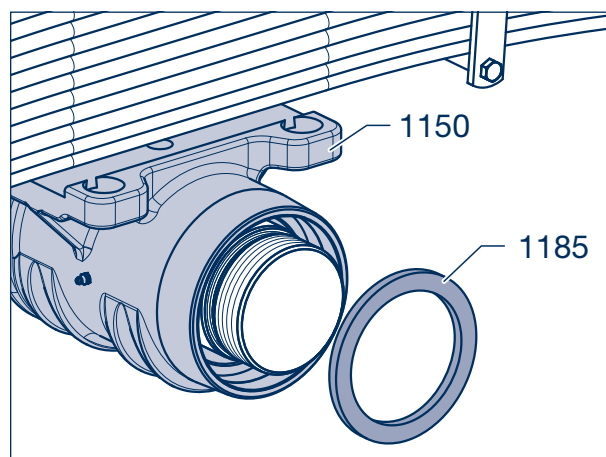

Picture 8

[14] Screw on the keyed nut (1190) until it is tight.

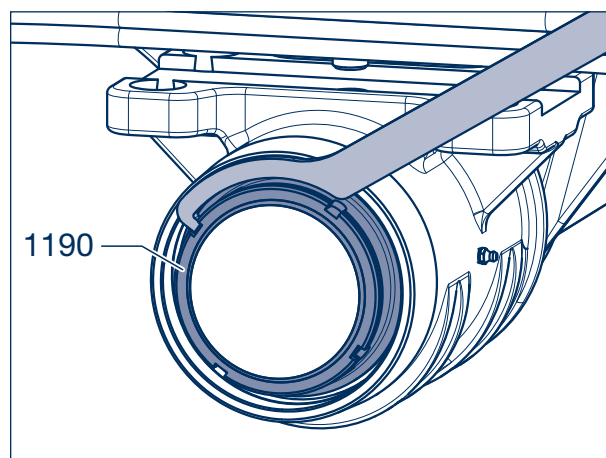

Picture 9

- [15] If the hole for the pin (1196) on the hooked snap ring (1195) does not fit, drill a new 10 mm diameter hole in the bearing journal. For this purpose, use the hole in the slotted nut as a template.
- [16] Insert hooked snap ring into the respective hole (arrow).

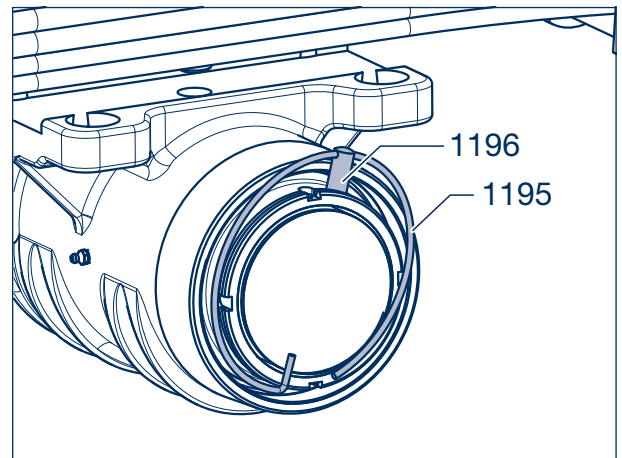

Picture 10

- [17] Lower the spring (1000).
- [18] Screw on hub cap (1200) and tighten with wrench.

Tightening torque:

M 170 x 3 M = 900 Nm

M 230 x 3 M = 900 Nm

- [19] Grease the trunnion block (1150) at the front and rear conical greasing nipples (1160) with BPW special longlife grease ECO-LiⁱPlus.

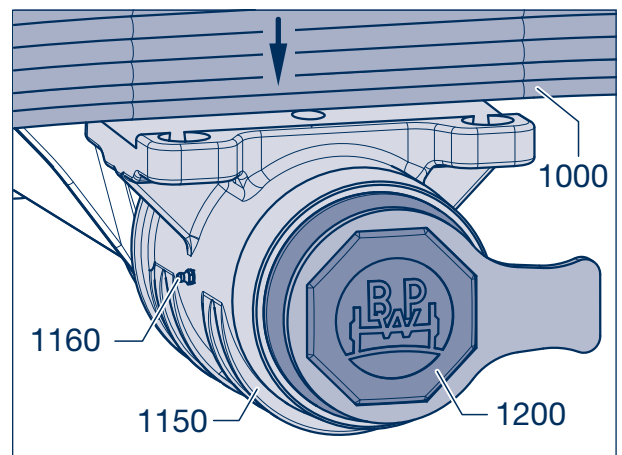

Picture 11

- [20] Insert the trunnion U-bolt (1250) on the trunnion block (1150) and place the top plate (1254) in position.
- [21] Tighten the nuts (1257/1, SW 55) uniformly and evenly to the specified torque.

Tightening torque:

M 36 (SW 55) M = 1555 Nm

- [22] Install the lock nuts (1257/2).
- [23] Refit the wheels and lower the vehicle to the ground.

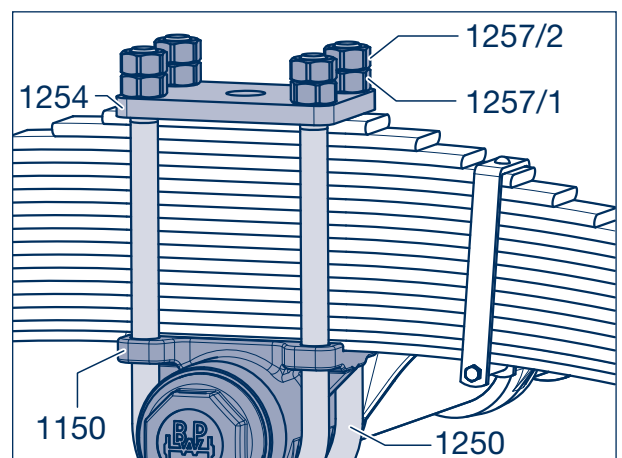

Picture 12

9 Removing and installing axle (series ECO Cargo W)

9.1 Removing

- [1] Block up the vehicle at the frame securely.
- [2] Remove the wheels, air lines for brake cylinders and cable for parking brake of the relevant axle.
- [3] Support axle with a trolley jack to prevent accidents.
- [4] Unscrew the nuts (1057) from the U-bolts (1050) of the relevant axle at the spring housings (1070).

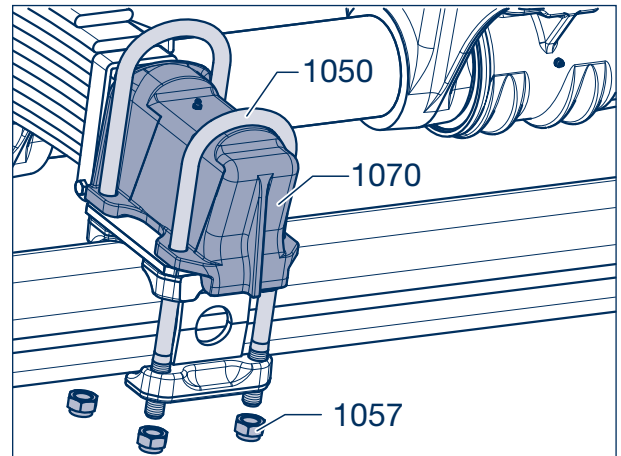

Picture 1

- [5] Remove U-bolts (1050) and take off spring housings (1070) together with spring cushions (1060).
- [6] Carefully lower axle and withdraw from the side.

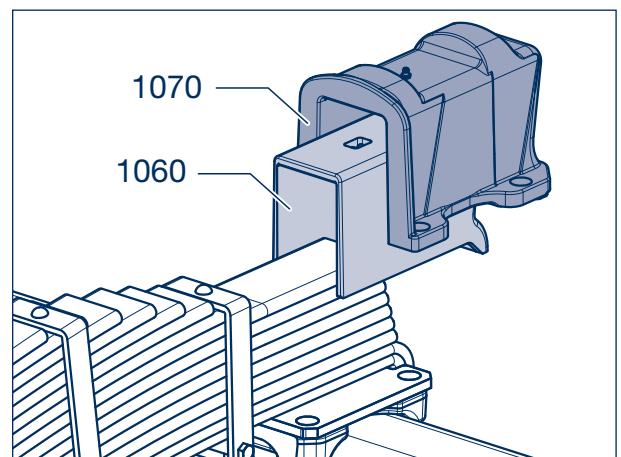

Picture 2

9.2 Installing

- [7] Place axle on a trolley jack to prevent accidents, push under the frame and raise sufficiently until the axle flanges are positioned in the middle below the ends of the springs.
-  The axles are installed as described in chapter 7, work steps 21 to 29.
- [8] The distance between the axles must also be measured on both sides. Unscrew hub caps.



Note:

- In the case of new hub caps (embossed ®, ECO or ECO Plus under the BPW logo) (picture. 3) the caps do not need to be unscrewed.
- The triangle (Δ) in the BPW logo is located in the centre if an ®, ECO or ECO Plus is stamped below the BPW logo (picture 3).

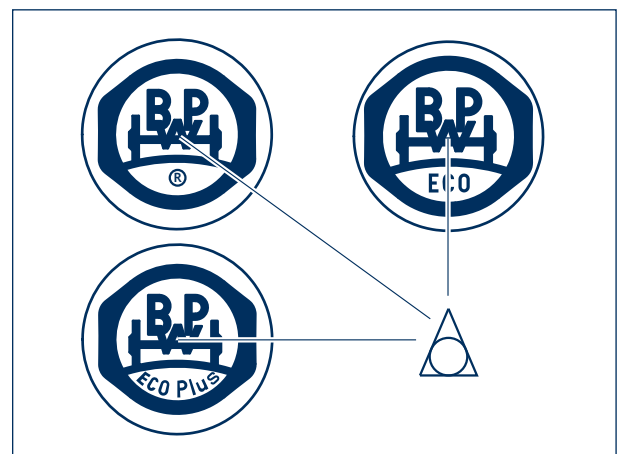

Picture 3

- [9] Measure distance from tip of centre punch to tip of centre punch at stub axle or hub caps. The measurement can also be performed with a steel measuring tape.

**Repair guide!**

The difference in the distance between left and right must not be more than 4 mm.

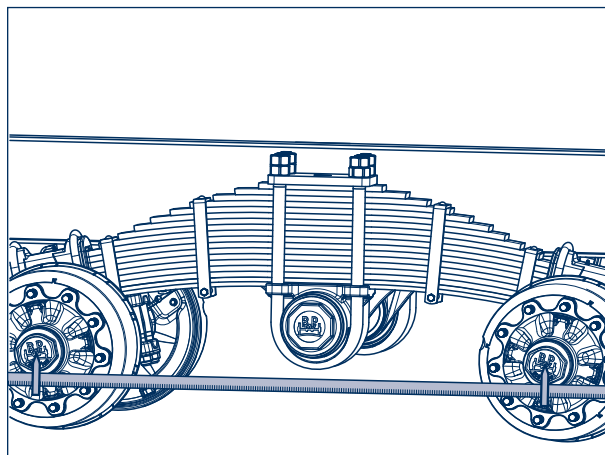

Picture 4

- [10] If necessary, the axles should be repositioned by welding materials onto the upper axle flanges (arrows).
- [11] Pack removed hub caps, if necessary, with a little BPW special longlife grease ECO-Li^{Plus} and screw in.
- [12] Fit on wheels and lower vehicle to the ground.
- [13] Re-make connections to air cylinders and parking brake.

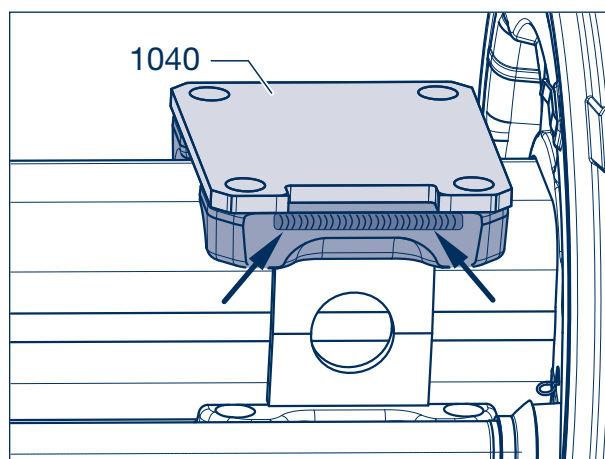

Picture 5

10 Spring hanger / Trunnion axle mounting (series ECO Cargo BW / GW)

10.1 Removing

- [1] Block up vehicle at frame to prevent accidents.
- 👉 Wheels can remain on.
- [2] Support trunnion axle (1105) with a trolley jack to prevent accidents.
- [3] Unscrew securing nuts (1125, SW 30 / SW 36) from the attachment bolts (1120) of the four bearing caps (1115), take off bearing cap.

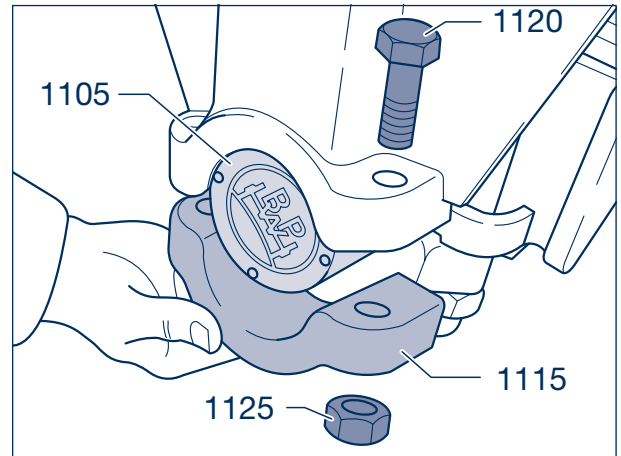

Picture 1

- [4] Unscrew lock nuts and nuts (1257, SW 46) of the trunnion U-bolts (1250).



Repair guide!
The trunnion U-bolts need not be removed.

- [5] **Series ECO Cargo GW**
Remove bottom part of lower trunnion block (1155) on both sides.
- [6] Pull top part of trunnion block (1150), if necessary off the trunnion U-bolts (1250).

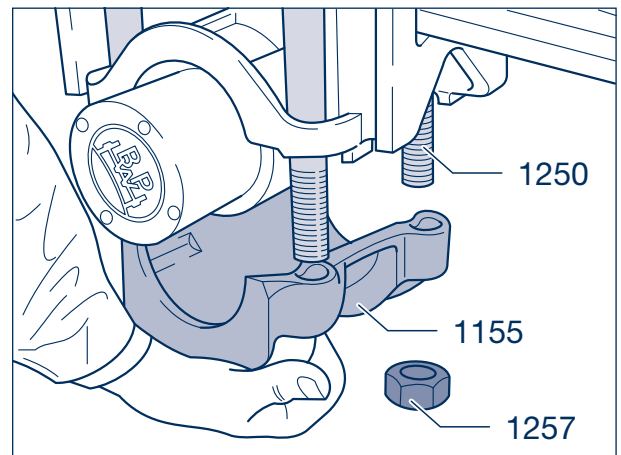

Picture 2



Repair guide!
If the upper trunnion block (1150) of the spring hangers on series ECO Cargo GW are not replaced, they can remain on the springs (1000); secure, if necessary, with a nut (1257) to prevent them dropping down.

Series ECO Cargo BW

Lower the trunnion (1105) with trunnion block (1150) and remove.

- [7] **Series ECO Cargo GW**
Lower the support axis (1105) slightly.
Pull the rubber bushing (1170) off the trunnion beam (1105). Examine bushings for wear, replace if necessary.

Series ECO Cargo BW

Pull the trunnion block (1150), the bronze bushing (1170) and rings (1175) if necessary, off the trunnion beam.

Examine bushings for wear, replace if necessary.

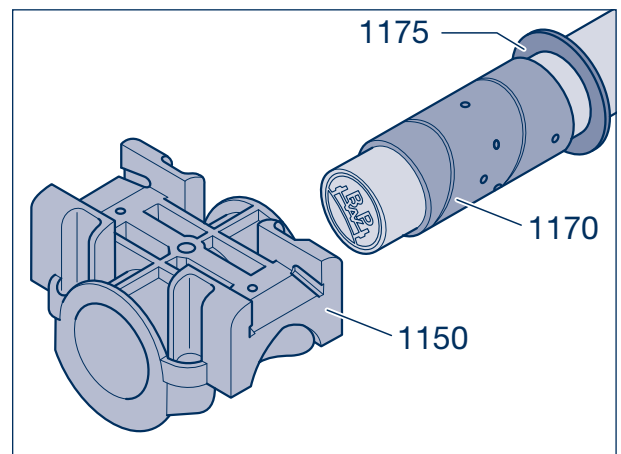

Picture 3

10.2 Installing

[8] Series ECO Cargo GW

Push a rubber bushing (1170) onto the axle beam (1105).

The side projection of the trunnion beam is approx. 95 mm.

Centre - centre bushing = spring centre

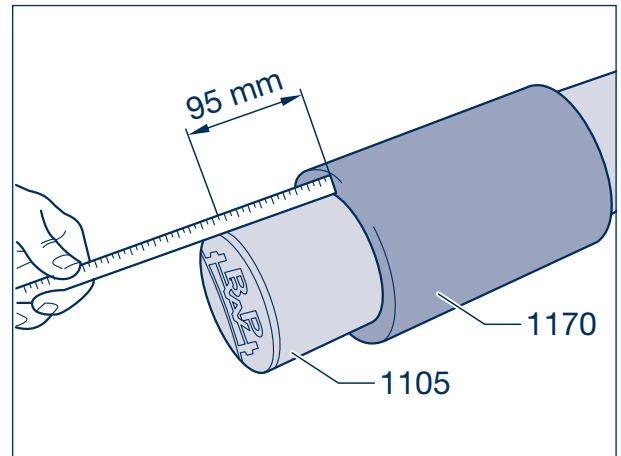

Picture 4

[8] Series ECO Cargo BW

Grease bronze bushing (1170) on inside and outside with BPW special longlife grease ECO-Li^{Plus}.

Note: Install ring (1175. Version 14 t). Push bronze bushing onto the trunnion beam (1105).

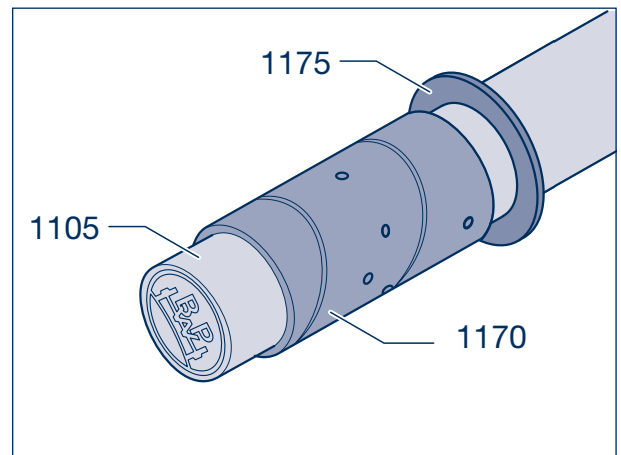

Picture 5

[9] Push trunnion block (1150) over the bronze bushing (1170) and align to spring centre.

Note: If necessary slide back the second ring (1175).

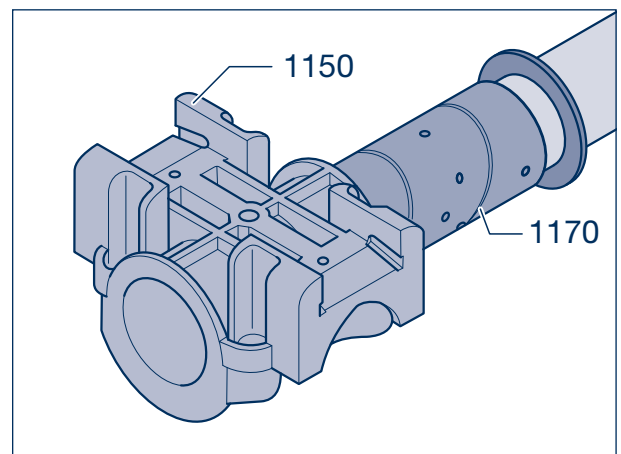

Picture 6

10 Spring hanger / Trunnion axle mounting (series ECO Cargo BW / GW)

[10] Place trunnion beam (1105) onto a trolley jack to prevent accidents, push it under the frame.

[11] **Series ECO Cargo GW**

Raise sufficiently until the rubber bushing (1170) is positioned in the top part of the trunnion block (1150).

Series ECO Cargo BW

Align the trunnion block (1150) with bronze bushing (1170) so that it is positioned in the middle below the leaf spring. Lift the support axle.

[12] Screw nuts (1257, SW 46) onto the trunnion U-bolts (1250), tighten uniformly and alternately to the specified torque and secure with lock nuts.

Tightening torque:

M 30 x 2 (SW 46) M = 980 Nm

[13] Fit bearing caps (1110, 1115).



Repair guide!

Mount the bearing cover (1115) with the large bevel mounted to the outside.

[14] Screw new lock nuts (1125, SW 30 / SW 36) onto the bolts (1120) and tighten to the specified torque.

Tightening torques:

M 20 (SW 30) M = 320 Nm

M 24 (SW 36) M = 570 Nm

[15] Grease trunnion block (1150) - series ECO Cargo BW - with BPW special longlife grease ECO-Li^{Plus}.

[16] Lower vehicle to the ground.

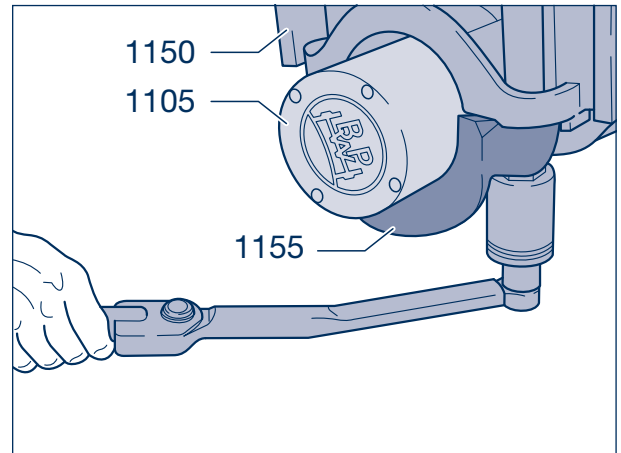

Picture 7

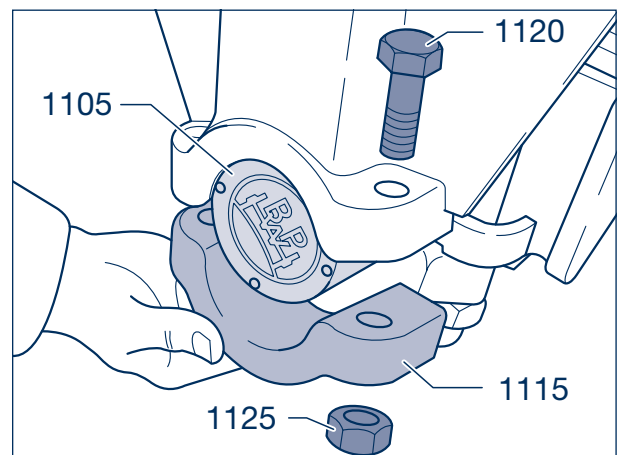

Picture 8

Replacing leaf springs 11

(series ECO Cargo BW / GW)

11.1 Removing

- [1] Block up the vehicle securely at the frame.
- [2] Remove the wheels, air lines for the brake cylinders and the cable for the parking brake.
- [3] Support complete suspension assembly at the trunnion beam (1105) with a trolley jack to prevent accidents.
- [4] Unscrew the securing nuts (1125, SW 30 / SW 36) from the attachment bolts (1120) of the four bearing caps (1110 / 1115), take off bearing caps.
- [5] Lower the complete assembly carefully and pull it out to the rear.

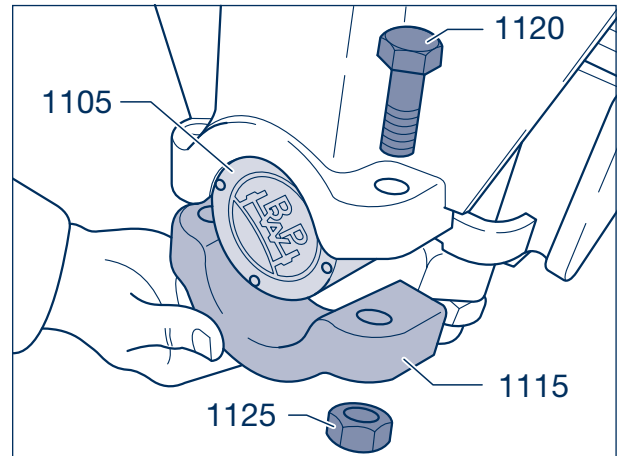

Picture 1

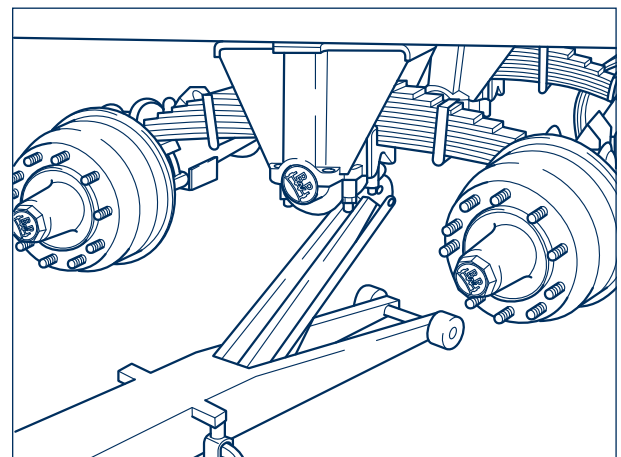

Picture 2



Repair guide!

Secure the axles and support axles (1105) from rolling away and falling.

- [6] Unscrew lock nuts and nuts (1057, 1125, SW 30 / SW 36) from the trunnion U-bolts (1050), and remove the U-bolts.
- [7] Remove spring housing (1070) together with rubber plate (1040).
- [8] Unscrew lock nuts and nuts (1257, SW 46) of the axle U-bolts (1250) at the spring hanger, remove U-bolts.

Series ECO Cargo GW

Remove bottom part of trunnion block (1155).

- [9] Remove spring housing (1254) from the leaf spring (1000).

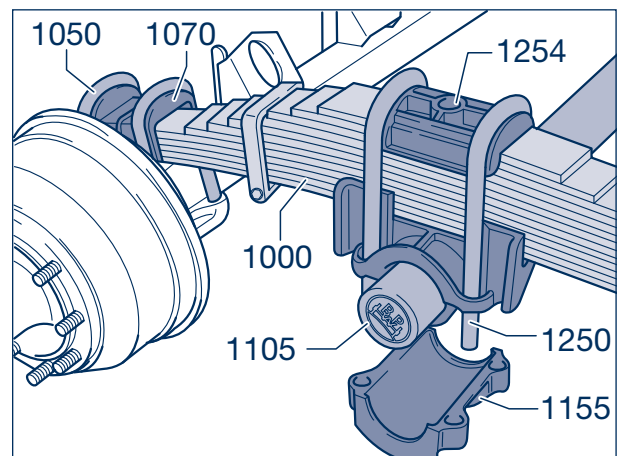

Picture 3

11 Replacing leaf springs (series ECO Cargo BW / GW)

- [10] Lift leaf spring (1000) off the trunnion block (1150).

Series ECO Cargo GW

Take trunnion block off the trunnion beam (1105).

- [11] Disassemble badly rusted springs which do not slide back into their normal position. See page 19 and 20. Clean the individual leaves thoroughly with a wire brush and check them for cracks.
- [12] Grease the cleaned spring leaves well with graphite grease.
- [13] Examine mounting holes of the bottom spring leave, replace bottom spring leaf if necessary. Install spring bolts and clamps.

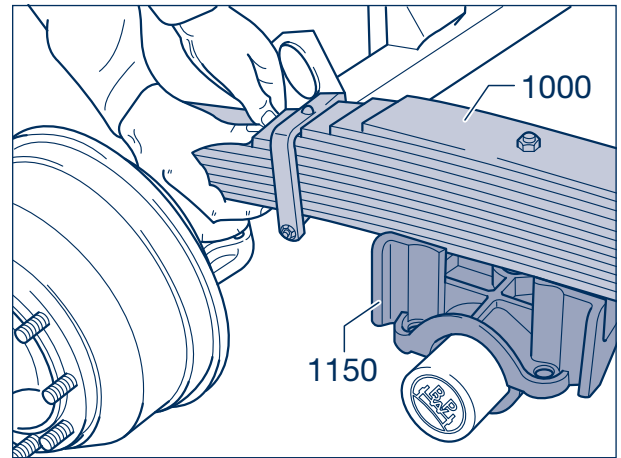

Picture 4

- [14] Check the pin of the axle plate (1028, arrow) for wear, open weld seams if necessary and remove pin plate.
- [15] Series ECO Cargo GW
Examine rubber bushing (1170) of spring hangers, replace bushings if necessary, see chapter 10.

Series ECO Cargo BW

Examine bronze bushing (1170) of spring hangers, replace bushings if necessary, see chapter 10.



Repair guide!

If signs of wear are present, always examine both sides, repair if necessary.

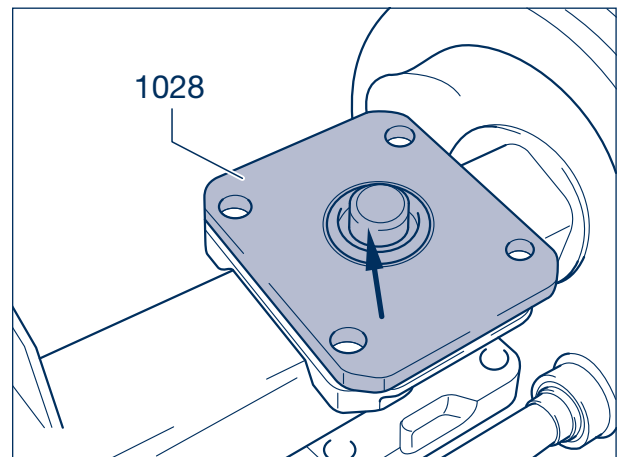

Picture 5

11.2 Installing

- [16] Series ECO Cargo GW
Place the trunnion block (1150) onto the rubber bushing (1170) of the axle (1105).

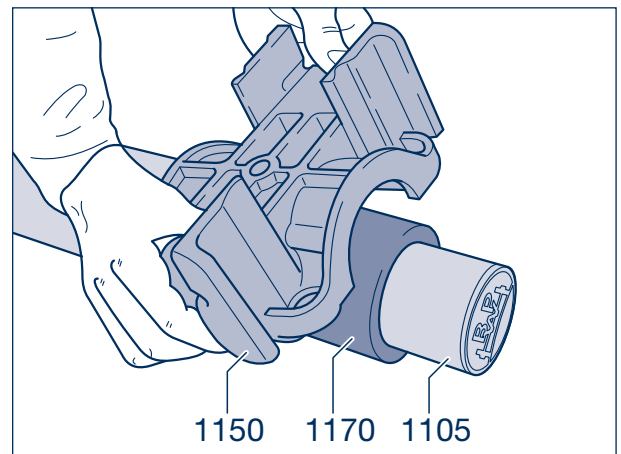

Picture 6

Series ECO Cargo BW / GW

- [17] Refit leaf spring (1000) so that the head of the spring centre bolt (1010) engages in the mounting hole in the trunnion block (1150 / arrows).

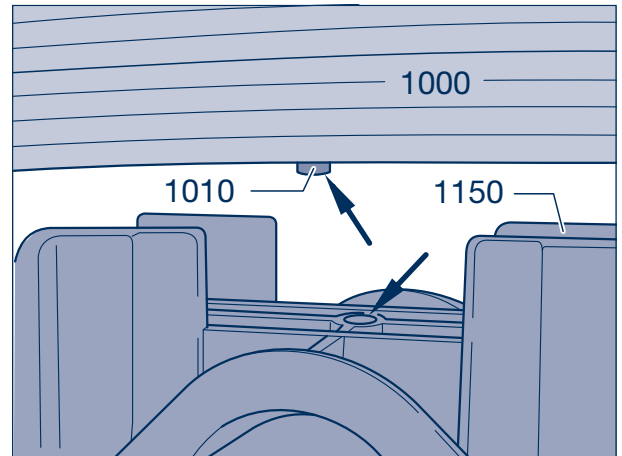
*Picture 7*

- [18] The pin of the axle plate (1028) must engage in the outer locating hole of the lower spring leaf (picture 8 / arrows).

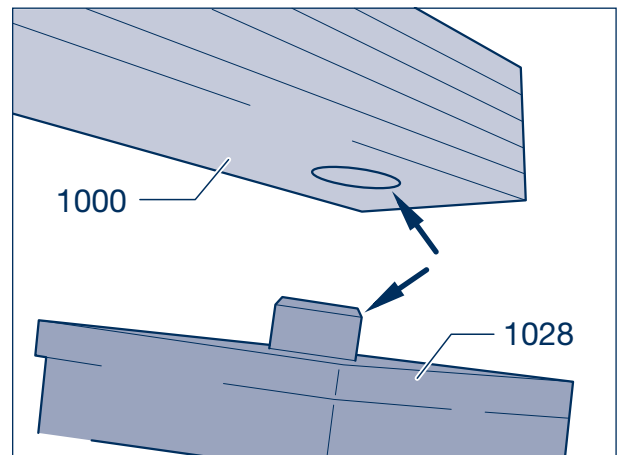
*Picture 8***Repair guide!**

If the axle plate (1028) has been separated, place new axle plate onto axle and align.

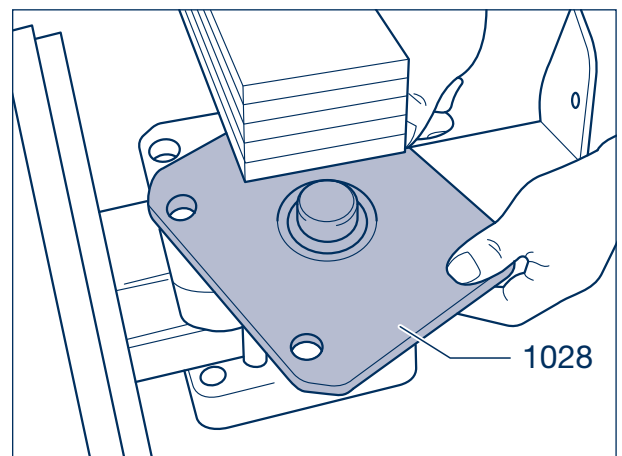
*Picture 9*

11 Replacing leaf springs (series ECO Cargo BW / GW)

[19] Fit middle spring housing (1254) onto the leaf spring (1000).

[20] Insert axle U-bolts (1254).

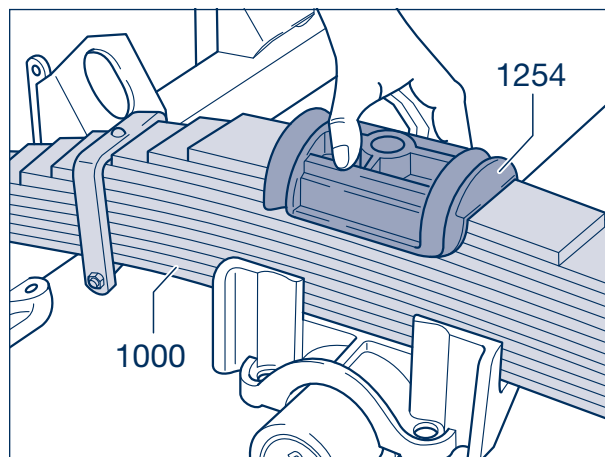

Picture 10

Series ECO Cargo GW

Slide the lower bearing block (1155) over the U-bolt (1250).

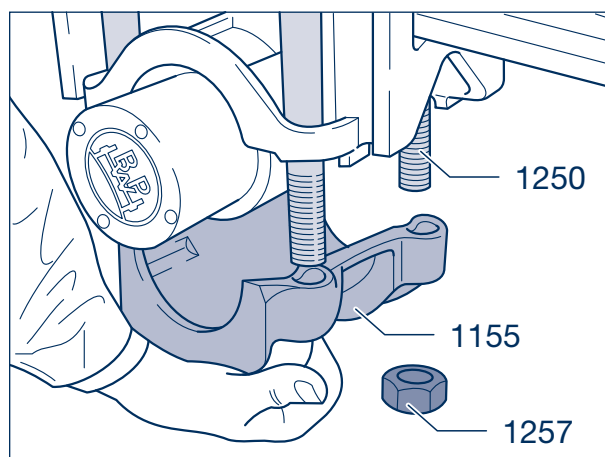

Picture 11

[21] Screw nuts (1257, SW 46) onto the axle U-bolts (1250) and tighten uniformly and alternately to the specified torque and secure with lock nuts.

Tightening torque:

M 30 x 2 (SW 46)

M = 980 Nm

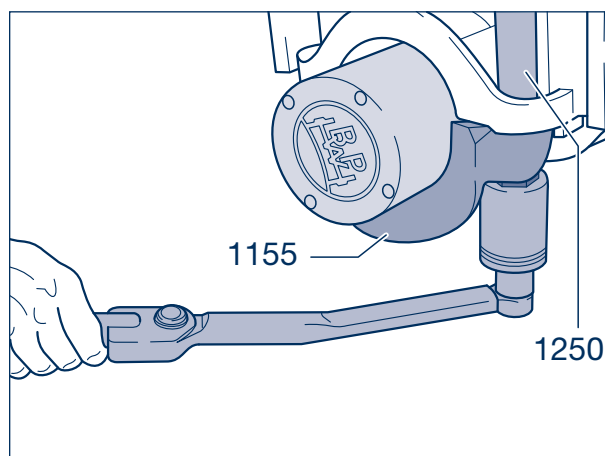

Picture 12

- [22] Insert new rubber plate (1040) for each outer spring housing (1070) and fit on spring housing.
- [23] Insert new axle U-bolts (1050).
- [24] Screw on nuts (1057, 1125, SW 30 / SW 36) but do not tighten until after aligning the axle.



Repair guide!
When using locking nuts (1125), these must be renewed.

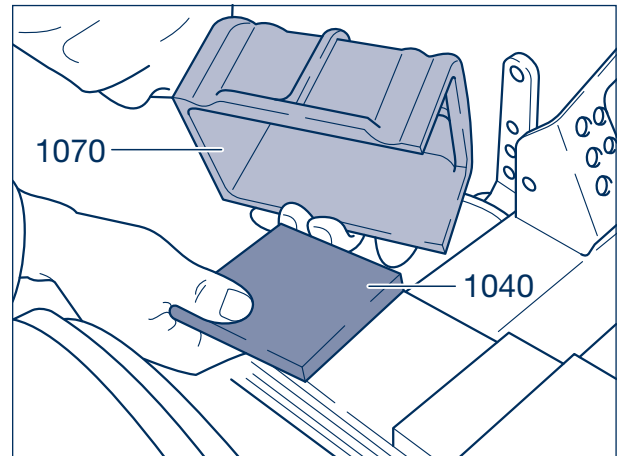

Picture 13

- [25] Raise the assembly until it is correctly seated with the trunnion beam (1105) in the trunnion block part (1150) and install the bearing cap (1110, 1115).



Repair guide!
Mount the bearing cover (1115) with the large bevel mounted to the outside.

- [26] Insert attachment bolts (1120), screw on new securing nuts (1125) and tighten to the specified torque.

Tightening torques:

M 20 (SW 30) M = 320 Nm

M 24 (SW 36) M = 570 Nm

- [27] Measure axle distance on left and right, correct if necessary, see chapter 9.

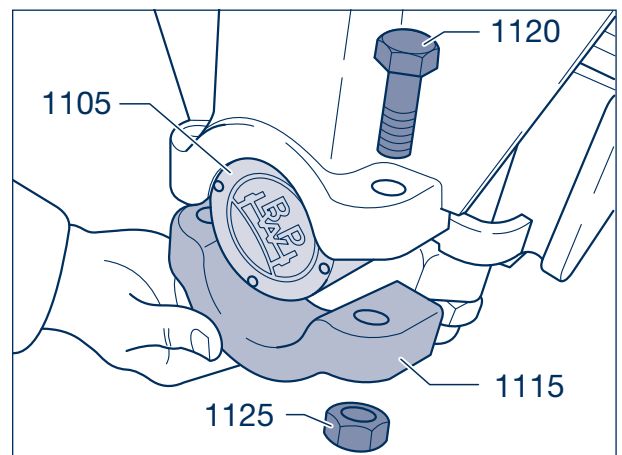

Picture 14

- [28] Tighten nuts of the axle U-bolts to the specified torque, secure with lock nuts.

Tightening torques:

M 20 (SW 30) M = 450 Nm

M 24 (SW 36) M = 700 Nm

- [29] After the axle has been aligned and the attachment nuts have been tightened, the new axle plates (1028) must be welded to the axle beams approx. 80 mm on both sides.

- [30] Connect up the air lines for the brake cylinders, the cable for the parking brake and refit on the wheels. Lower the vehicle to the ground.

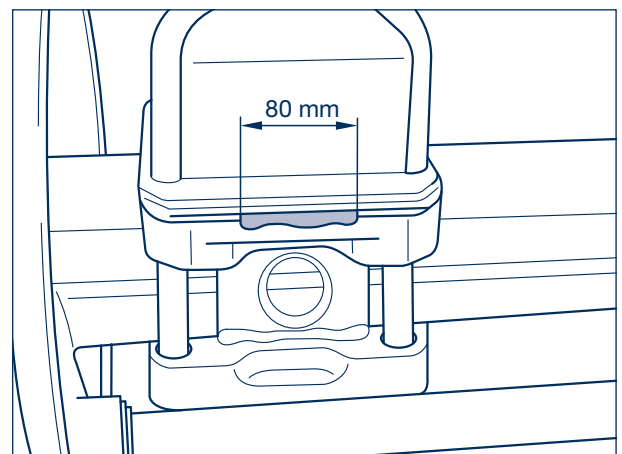

Picture 15

12 Removing and installing axle (series ECO Cargo BW / GW)

12.1 Removing

- [1] Block up the vehicle securely at the frame.
- [2] Remove the wheels, the air lines for the brake cylinders and the cable for the parking brake.
- [3] Support axle to be removed with a trolley jack to prevent accidents.
- [4] Unscrew the nuts (1057, 1125, SW 30 / SW 36) of the axle U-bolt (1050) on the left and right of the axle to be removed and take off the U-bolts.
- [5] Remove both spring housings (1070) with the rubber plates (1040).
- [6] Lower the axle and pull it out (picture 1).
- [7] Examine locating holes of the bottom spring layer, replace bottom spring layer, if necessary, see chapter 8.
- [8] Check the pin (arrow) of the axle plate (1028) for wear and replace it, if necessary, see chapter 11.

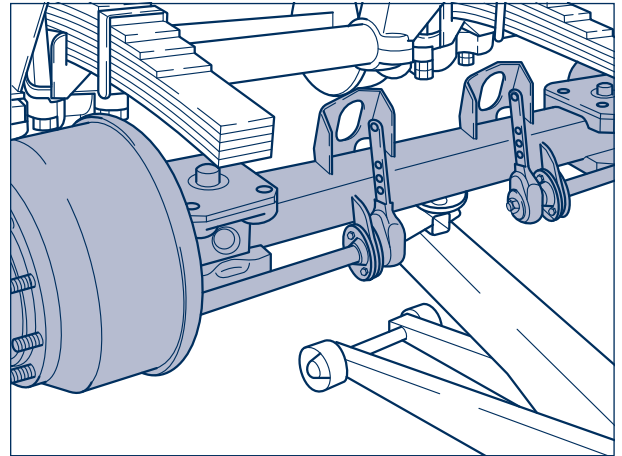

Picture 1

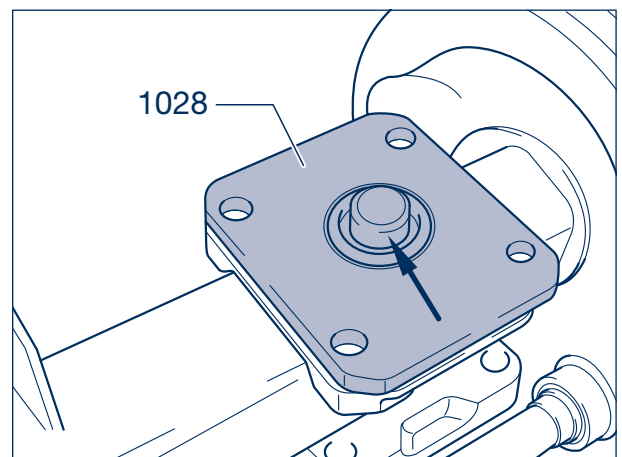

Picture 2

12.2 Einbau

- [9] Place axle on a trolley jack to prevent accidents, position it below the leaf springs (1000) and raise sufficiently until the pin of the axle plate (1028) engages in the locating hole of the leaf spring (arrows).



Repair guide!

If the axle plate has been removed, place new plate onto the axle and align, see chapter 11.

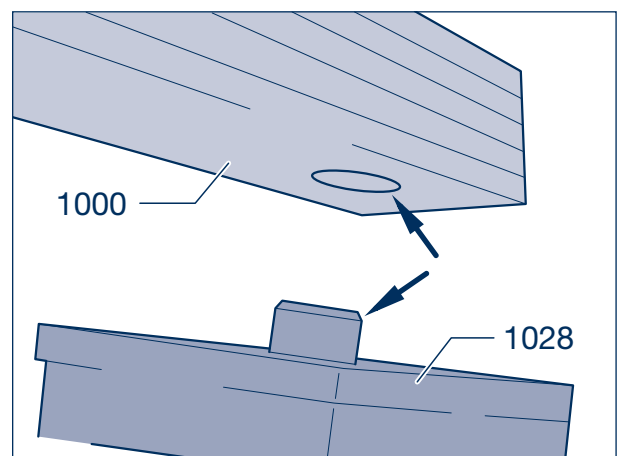

Picture 3

- [10] Insert new rubber plate (1040) into each outer spring housing (1070) and fit spring housings.

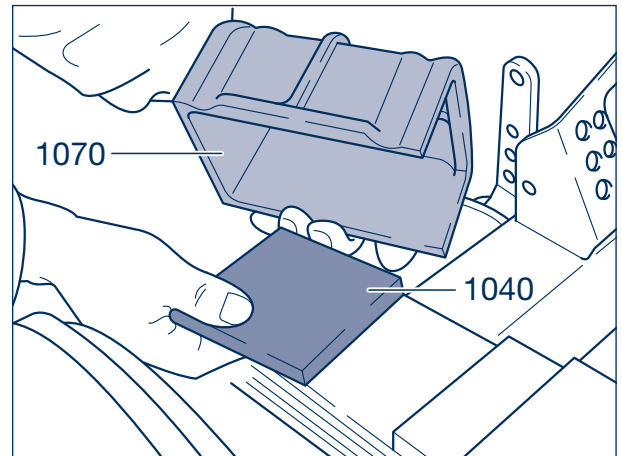

Picture 4

- [11] Insert the new axle U-bolts (1050).
- [12] Screw on nuts, measure distance between axles on left and right, correct if necessary. See page 28 and 29.
- [13] Tighten the nuts of the axle U-bolts uniformly and alternately to the specified torque and secure with lock nuts.

Tightening torques:

M 20 (SW 30)	M = 450 Nm
M 24 (SW 36)	M = 700 Nm



Repair guide!

If new pin plates (1028) have been fitted, these must be welded to the axle beam, see page 37.

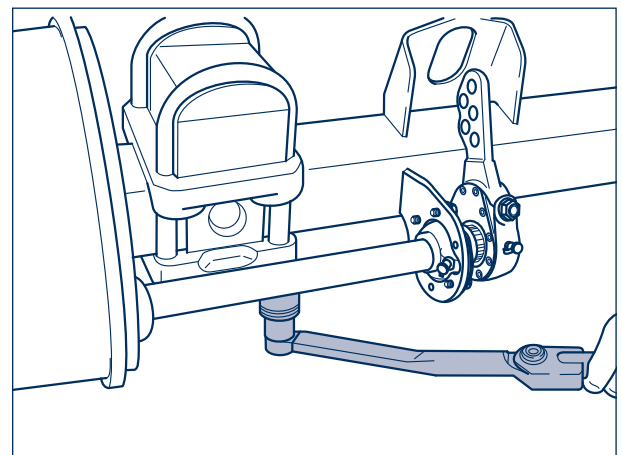

Picture 5

- [14] Re-connect brake cylinder hoses, parking brake cable. Refit wheels.



BPW-WH-W-BW-GW 35251401e

BPW is a globally leading manufacturer of intelligent running gear systems for trailers and semi-trailers. As an international mobility and system partner, we offer a wide range of solutions for the transport industry from a single source, from axle to suspension and brake to user-friendly telematics applications.

We thereby ensure outstanding transparency in loading and transport processes and facilitate efficient fleet management. Today, the well-established brand represents an international corporation with a wide product and service portfolio for the commercial vehicle industry. Offering running gear systems, telematics, lighting systems, composite solutions and trailer superstructures, BPW is the right system partner for automotive manufacturers.

BPW, the owner-operated company, consistently pursues one target: To always give you exactly the solution which will pay off. To this end, we focus our attention on uncompromising quality for high reliability and service life, weight and time-saving concepts for low operating and maintenance costs as well as personal customer service and a close-knit service network for quick and direct support. You can be sure that with your international mobility partner BPW, you always use the most efficient method.

Your partner on the path to economic viability



BPW Bergische Achsen Kommanditgesellschaft

Postbox 12 80 · 51656 Wiehl, Germany · Phone +49 (0) 2262 78-0

info@bpw.de · www.bpw.de